



# CHORUS

This is the accepted manuscript made available via CHORUS. The article has been published as:

## Computable and Operationally Meaningful Multipartite Entanglement Measures

Jacob L. Beckey, N. Gigena, Patrick J. Coles, and M. Cerezo

Phys. Rev. Lett. **127**, 140501 — Published 27 September 2021

DOI: [10.1103/PhysRevLett.127.140501](https://doi.org/10.1103/PhysRevLett.127.140501)

# Computable and operationally meaningful multipartite entanglement measures

Jacob L. Beckey,<sup>1,2,3,4</sup> N. Gigena,<sup>5</sup> Patrick J. Coles,<sup>1,4</sup> and M. Cerezo<sup>1,4,6</sup>

<sup>1</sup>*Theoretical Division, Los Alamos National Laboratory, Los Alamos, New Mexico 87545, USA*

<sup>2</sup>*JILA, NIST and University of Colorado, Boulder, Colorado 80309, USA*

<sup>3</sup>*Department of Physics, University of Colorado, Boulder, Colorado 80309, USA*

<sup>4</sup>*Quantum Science Center, Oak Ridge, TN 37931, USA*

<sup>5</sup>*Faculty of Physics, University of Warsaw, Pasteura 5, 02-093 Warsaw, Poland*

<sup>6</sup>*Center for Nonlinear Studies, Los Alamos National Laboratory, Los Alamos, New Mexico 87545, USA*

Multipartite entanglement is an essential resource for quantum communication, quantum computing, quantum sensing, and quantum networks. The utility of a quantum state,  $|\psi\rangle$ , for these applications is often directly related to the degree or type of entanglement present in  $|\psi\rangle$ . Therefore, efficiently quantifying and characterizing multipartite entanglement is of paramount importance. In this work, we introduce a family of multipartite entanglement measures, called Concentratable Entanglements. Several well-known entanglement measures are recovered as special cases of our family of measures, and hence we provide a general framework for quantifying multipartite entanglement. We prove that the entire family does not increase, on average, under Local Operations and Classical Communications. We also provide an operational meaning for these measures in terms of probabilistic concentration of entanglement into Bell pairs. Finally, we show that these quantities can be efficiently estimated on a quantum computer by implementing a parallelized SWAP test, opening up a research direction for measuring multipartite entanglement on quantum devices.

*Introduction.* The presence of entanglement in quantum states is widely recognized as one of, if not the, defining property of quantum mechanics [1]. Since the development of quantum information theory [2, 3] it was realized that entanglement is a fundamental resource [4, 5] for quantum communications [6–9], quantum cryptography [10, 11], and quantum computing [12–14]. Recent advances in quantum control technologies have made it possible to harness the power of entanglement for quantum-enhanced sensing [15–17] and communications [18–20], and for showing quantum advantage using near-term quantum computers [21]. While the ubiquity of entangled quantum states as a resource is clear, their utility for these applications often depends on the degree of entanglement in the quantum state.

The nature of quantum entanglement is well understood for bipartite pure quantum states [2, 13, 22]. However, the same cannot be said for the multipartite entanglement of pure states [23], where the complexity of entanglement scales exponentially with the number of parties. In fact, already for a system of three qubits there exists two different, and inequivalent, types of genuine tripartite entanglement, such that states of the two different kinds cannot be exactly transformed onto the other via the action of Local Operations and Classical Communications (LOCC) [24]. While the study of multipartite entanglement has received considerable attention [25–33] there does not exist a single unambiguous way to detect, quantify and characterize multipartite entanglement. Hence, improving our knowledge on the nature of the entanglement between multiple parties is not only crucial to better understanding the underlying structure of quantum mechanics, but it is also a fundamental step towards enhancing emergent technologies such as distributed quantum sensing [34], longer baseline telescopes [35], and various quantum internet applica-

tions [36–38].

The advent of quantum computing technologies brings forth the possibility of verifying and characterizing the multipartite entanglement present in states prepared on these near-term quantum devices. In this context, entanglement measures that are not only theoretically relevant, but that can also be estimated via quantum algorithms [31, 39–44], become particularly attractive as characterization tools. For instance, it was shown [29, 45] that given an  $n$ -qubit state  $|\psi\rangle$ , the linear entropies  $\frac{1}{2}(1 - \text{Tr}\rho_j^2)$  of the single-qubit reduced states  $\rho_j$  can be used to study the entanglement in  $|\psi\rangle$ . Moreover, since the SWAP test [46–50] can be used to compute linear entropies, these measures can be efficiently estimated on quantum computers or optical quantum devices.

In this work, we introduce a family of quantities, called *Concentratable Entanglements*, which characterize and quantify the multipartite entanglement in an arbitrary  $n$ -qubit pure state  $|\psi\rangle$ . We first prove that each Concentratable Entanglement does not increase, on average, under LOCC operations, and hence forms an entanglement monotone. Then, we show that by combining Concentratable Entanglements one can obtain several quantities of interest, which can quantify properties such as the entanglement in, and between, subsystems, as well as the total entanglement in  $|\psi\rangle$ . We then discuss how these quantities can be efficiently estimated on a quantum computer given two copies of  $|\psi\rangle$ , and employing constant-depth  $n$ -qubit parallelized SWAP tests. Finally, we discuss the operational meaning of the Concentratable Entanglement as the probability of obtaining Bell pairs between qubits in the different copies of  $|\psi\rangle$ .

Our results generalize previous results in the literature in the sense that: (1) several entanglement measures correspond to a special case of the Concentratable Entanglements [28, 29, 32, 45, 51], (2) we prove a conjecture

in Ref. [42], where it was hypothesized that the parallelized SWAP test can provide the basis for constructing a pure state multipartite entanglement monotone. Finally, the broader implication of our work is to promote a research direction of studying multipartite entanglement using quantum devices, such as cloud-based quantum computers.

*Concentratable Entanglement.* Consider an  $n$ -qubit pure quantum state  $|\psi\rangle$ . We denote  $\mathcal{S} = \{1, 2, \dots, n\}$  as the set of labels for each qubit, and  $\mathcal{P}(\mathcal{S})$  as its power set (i.e., the set of subsets, with cardinality  $|\mathcal{S}| = 2^n$ ). We introduce the *Concentratable Entanglements* as a family of entanglement monotones that characterize and quantify the multipartite entanglement in  $|\psi\rangle$ .

**Definition 1.** For any set of qubit labels  $s \in \mathcal{P}(\mathcal{S}) \setminus \{\emptyset\}$ , the *Concentratable Entanglement* is defined as

$$\mathcal{C}_{|\psi\rangle}(s) = 1 - \frac{1}{2^{c(s)}} \sum_{\alpha \in \mathcal{P}(s)} \text{Tr} \rho_\alpha^2, \quad (1)$$

where  $c(s)$  is the cardinality of the set  $s$ , and  $\mathcal{P}(s)$  its power set. Here we denote by  $\rho_\alpha$  the joint reduced state, associated to  $|\psi\rangle$ , of the subsystems labeled by the elements in  $\alpha$  (with  $\alpha = \emptyset$  leading to  $\rho_\alpha := 1$ ).

Equation (1) shows that each  $\mathcal{C}_{|\psi\rangle}(s)$  is the average of the entanglement between the subsets of qubits with labels in  $s$  and the rest of the system. This means that different Concentratable Entanglements can measure both bipartite and multipartite entanglements according to how  $s$  is defined. For instance taking the smallest set possible, i.e.,  $s = \{j\}$  with  $j = 1, \dots, n$ , one finds  $\mathcal{C}_{|\psi\rangle}(\{j\}) = \frac{1}{2} (1 - \text{Tr} \rho_j^2)$ . Thus, when averaged over  $\{j\}$ , one recovers the measures in [29, 45] which quantify the bipartite entanglement between the  $j$ -th qubit and the rest. On the other hand, taking the largest set possible, i.e.,  $s = \mathcal{S}$ ,  $\mathcal{C}_{|\psi\rangle}(\mathcal{S})$  quantifies the overall entanglement in  $|\psi\rangle$  across all cuts, and as discussed below, this case corresponds to the entanglement measure conjectured in [42]. Moreover, in this case we also recover the entanglement measure of [51] as a special case of the Concentratable Entanglements. Including these extremal cases, there are a total of  $2^n - 1$  Concentratable Entanglements according to Definition 1.

*Efficient Computation.* A fundamental aspect of the Concentratable Entanglements is that they can be efficiently estimated on a quantum computer. While each purity,  $\text{Tr}[\rho_\alpha^2]$ , in (1) can be computed via an overlap test [49], one can also use two copies of the state  $|\psi\rangle$  and  $n$  ancilla qubits to employ the  $n$ -qubit parallelized SWAP test depicted in Fig. 1 (see Supplementary Information for a discussion on the SWAP test). From Fig. 1, it is clear that the  $k$ -th ancilla qubit is used to perform a controlled SWAP test on the  $k$ -th qubit of each copy of  $|\psi\rangle$ . The tests are independent and thus factorizable. This implies that the  $n$ -qubit parallelized SWAP test has a constant circuit depth for any number of qubits.

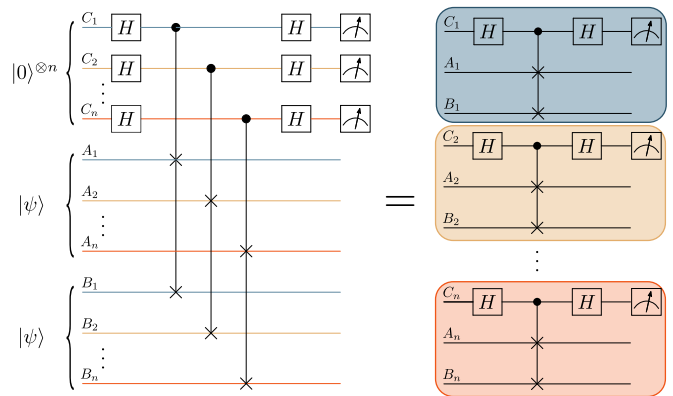

**FIG. 1. Circuit for the  $n$ -qubit parallelized SWAP test.** Given two copies of the quantum state  $|\psi\rangle$ , and  $n$  ancilla qubits, the  $n$ -qubit parallelized SWAP test consists of employing the  $k$ -th ancilla to perform a controlled swap test on the  $k$ -th qubit of each copy of  $|\psi\rangle$ . Since the  $n$  SWAP test can be factorized, one can perform them in parallel, leading to a constant depth circuit.

Given the  $n$ -qubit parallelized SWAP test, we define the following relevant quantities. First, let  $p(\mathbf{z})$  be the probability of measuring the  $\mathbf{z}$  bitstring on the  $n$  control qubits, and let  $\mathcal{Z} = \{0, 1\}^n$  be the set of all such bitstrings. Then, the following proposition (proved in the Supplementary Information [52]) holds.

**Proposition 1.** The Concentratable Entanglement can be computed from the outcomes of the  $n$ -qubit parallelized SWAP test as

$$\mathcal{C}_{|\psi\rangle}(s) = 1 - \sum_{\mathbf{z} \in \mathcal{Z}_0(s)} p(\mathbf{z}), \quad (2)$$

where  $\mathcal{Z}_0(s)$  is the set of all bitstrings with 0's on all indices in  $s$ .

Proposition 1 shows that  $\mathcal{C}_{|\psi\rangle}(s)$  can be computed by performing the parallelized SWAP test on all qubits and adding the probabilities where the control qubits with indices in  $s$  are measured in the  $|0\rangle$  state. Since this corresponds to a conditional probability, one can also perform SWAP tests only on the qubits with indexes in  $s$  (requiring just  $c(s)$  ancillary qubits) and express the Concentratable Entanglement as  $\mathcal{C}_{|\psi\rangle}(s) = 1 - p(\mathbf{0}_x)$ . Here  $p(\mathbf{0}_x) = \sum_{\mathbf{z} \in \mathcal{Z}_0(s)} p(\mathbf{z})$  denotes the probability of obtaining the all-zero result from the SWAP test on the qubits with labels in  $s$ .

Here we remark that Eqs. (1) and (2) are complementary in the sense that the number of terms in the summations are inversely proportional. That is, the summation in Eq. (1) contains  $2^{c(s)}$  terms, while that of (2) contains  $2^{n-c(s)}$  terms. Hence, we remark that it is preferable to employ Eq. (2) when analyzing multipartite entanglement, as this avoids potentially having to compute a prohibitively large number of purities as those required in other entanglement measures [53]. For instance, if

$(n - c(s)) \in \mathcal{O}(\log(n))$  then (2) only contains number of terms in  $\mathcal{O}(\text{poly}(n))$ . For the purpose of analyzing multipartite entanglement we henceforth focus on Eq. (2).

Finally, we remark, that, as shown in the Supplementary Information, the SWAP test still works when the two copies of  $|\psi\rangle$  are not exactly the same. Specifically, let  $|\psi\rangle$  and  $|\psi'\rangle$  be two faulty copies of the state with  $\| |\psi\rangle\langle\psi| - |\psi'\rangle\langle\psi'| \|_1 \leq \varepsilon$ , then, we find that the error in the Concentratable Entanglement is upper-bounded by  $\mathcal{O}(\varepsilon^2)$ , indicating that small errors in the state lead to small Concentratable Entanglement difference.

*Properties of  $\mathcal{C}_{|\psi\rangle}(s)$ .* We now present our main results which provide properties and additional insight for the Concentratable Entanglements. The proofs of these results are provided in the Supplementary Information.

**Theorem 1.** *The Concentratable Entanglement has the following properties:*

1.  $\mathcal{C}_{|\psi\rangle}(s)$  is non-increasing, on average, under LOCC operations and hence is a well-defined pure state entanglement measure.
2. If  $|\psi\rangle$  is a separable state of the form  $|\psi\rangle = \bigotimes_{j=1}^n |\phi_j\rangle$ , then  $\mathcal{C}_{|\psi\rangle}(s) = 0$  for all  $s \in \mathcal{P}(\mathcal{S}) \setminus \{\emptyset\}$ .
3.  $\mathcal{C}_{|\psi\rangle}(s') \leq \mathcal{C}_{|\psi\rangle}(s)$  if  $s' \subseteq s$ .
4. Subadditivity,  $\mathcal{C}_{|\psi\rangle}(s \cup s') \leq \mathcal{C}_{|\psi\rangle}(s) + \mathcal{C}_{|\psi\rangle}(s')$  for  $s \cap s' = \emptyset$ .
5. Continuity, let  $|\psi\rangle$  and  $|\phi\rangle$  be two states such that  $\| |\psi\rangle\langle\psi| - |\phi\rangle\langle\phi| \|_1 \leq \varepsilon$ , then  $|\mathcal{C}_{|\psi\rangle}(s) - \mathcal{C}_{|\phi\rangle}(s)| \leq 2\varepsilon$ .

Here, 3) guarantees that the Concentratable Entanglement always measures less entanglement in any subsystem of  $s$ . In addition, we remark that combining 3) and 4) we have  $\{\mathcal{C}_{|\psi\rangle}(s), \mathcal{C}_{|\psi\rangle}(s')\} \leq \mathcal{C}_{|\psi\rangle}(s \cup s') \leq \mathcal{C}_{|\psi\rangle}(s) + \mathcal{C}_{|\psi\rangle}(s')$  for  $s \cap s' = \emptyset$ .

To further understand the Concentratable Entanglements measures entanglement, we provide additional details on the probabilities  $p(\mathbf{z})$ . First, consider the following explicit formula for the probabilities  $p(\mathbf{z})$ .

**Proposition 2.** *Given the expansion of the state  $|\psi\rangle = \sum_{\mathbf{i}} c_{\mathbf{i}} |i_1\rangle |i_2\rangle \cdots |i_n\rangle$ , the probability  $p(\mathbf{z})$  for any  $\mathbf{z} \in \mathcal{Z}$  is given by*

$$p(\mathbf{z}) = \frac{1}{2^n} \sum_{\mathbf{i}, \mathbf{i}', \mathbf{j}, \mathbf{j}'} c_{\mathbf{i}} c_{\mathbf{i}'} c_{\mathbf{j}}^* c_{\mathbf{j}'}^* T_{\mathbf{i}\mathbf{i}'\mathbf{j}\mathbf{j}'}(\mathbf{z}), \quad (3)$$

where  $T_{\mathbf{i}\mathbf{i}'\mathbf{j}\mathbf{j}'}(\mathbf{z}) = \prod_k (\delta_{i_k j_k} \delta_{i'_k j'_k} + (-1)^{z_k} \delta_{i_k j'_k} \delta_{i'_k j_k})$ , and where  $z_k$  denotes the  $k$ -th bit in  $\mathbf{z}$ .

Alternatively, one can also express  $p(\mathbf{z})$  as a function of purities of reduced states of  $|\psi\rangle$ . Let us define as  $w(\mathbf{z})$  the Hamming weight of  $\mathbf{z}$ , and let  $\mathcal{S}_1 \subseteq \mathcal{S}$  be the set of labels for the bits in  $\mathbf{z}$  that are equal to 1 (with  $|\mathcal{S}_1| = w(\mathbf{z})$ ). Finally, let  $c_{h_s}$  be the cardinality of  $\mathcal{S}_h \cap s$ . One finds

$$p(\mathbf{z}) = \frac{1}{2^n} \sum_{s \in \mathcal{P}(\mathcal{S})} (-1)^{c_{h_s}} \text{Tr} \rho_x^2. \quad (4)$$

Equation (4) leads to the following proposition.

**Proposition 3.** *If  $\mathbf{z}$  has odd Hamming weight (if  $w(\mathbf{z})$  is odd), then  $p(\mathbf{z}) = 0$ .*

Proposition 3 has several implications. First, one can see that by performing the  $n$ -qubit parallelized SWAP test, one can never measure a bitstring with an odd number of ones. Then, the formula for the Concentratable Entanglements in Proposition 1 can be expressed as

$$\mathcal{C}_{|\psi\rangle}(s) = \sum_{\mathbf{z} \in \mathcal{Z}_1^{\text{even}}(s)} p(\mathbf{z}), \quad (5)$$

where we recall that  $\mathcal{Z}_0(s)$  was defined as the set of all bitstrings with 0's on all indices in  $s$ , and where we respectively define  $\mathcal{Z}_1^{\text{even}}(s)$  and  $\mathcal{Z}_1^{\text{odd}}(s)$  as the complements of  $\mathcal{Z}_0(s)$  with even and odd Hamming weight, such that  $\mathcal{Z}_0(s) \cup \mathcal{Z}_1^{\text{even}}(s) \cup \mathcal{Z}_1^{\text{odd}}(s) = \mathcal{Z}$ . Simply said,  $\mathcal{Z}_1^{\text{even}}(s)$  is the set of bitstrings with even Hamming weight and with at least a 1 in an index in  $s$ . For instance, if  $s = \mathcal{S}$  (i.e., when the Concentratable Entanglement measures all the correlations in  $|\psi\rangle$ ) then  $\mathcal{C}_{|\psi\rangle}(\mathcal{S}) = 1 - p(\mathbf{0}) = \sum_{\mathbf{z}: w(\mathbf{z}) \text{ even}} p(\mathbf{z})$ , and we recover exactly the conjectured measure of entanglement of [42].

Equation (5) shows that the information of the multipartite entanglement in  $|\psi\rangle$  is encoded in the probabilistic outcomes of the  $n$ -qubit parallelized SWAP test when an even number of control qubits are measured in the  $|1\rangle$  state. For instance, the probability of measuring a bitstring with Hamming weight  $w(\mathbf{z}) = 2$ , where  $z_k = z_{k'} = 1$  contains information regarding the bipartite entanglement between qubits  $k$  and  $k'$ . Specifically, the following proposition holds.

**Proposition 4.** *Let  $|\psi\rangle$  be a bi-separable state  $|\psi\rangle = |\psi\rangle_A \otimes |\psi\rangle_B$ . Then for any bitstring  $\mathbf{z}$  of Hamming weight  $w(\mathbf{z}) = 2$ , where  $z_k = z_{k'} = 1$  we have  $p(\mathbf{z}) = 0$  if qubit  $k$  is in subsystem  $A$ , and qubit  $k'$  is in subsystem  $B$ .*

Proposition 4 can be generalized to show that the probability of measuring a bitstring with Hamming weight  $w(\mathbf{z})$  contains information regarding the entanglement between the qubits with labels in  $\mathcal{S}_1$ . That is, one can prove that  $p(\mathbf{z})$  is equal to zero if the qubits in  $\mathcal{S}_1$  belong to non-entangled partitions of  $|\psi\rangle$ .

Here we remark that while the  $p(\mathbf{z})$  contain information regarding the multipartite entanglement in  $|\psi\rangle$ , these probabilities are generally not entanglement monotones. The exception being  $p(\mathbf{1})$  when  $n$  is even, i.e., the probability of measuring all the control qubits in the  $|1\rangle$  state. For this special case we find the following.

**Proposition 5.** *If  $n$  is even, then  $p(\mathbf{1})$  is an entanglement monotone. Moreover, in this case  $p(\mathbf{1}) = \tau_{(n)}/2^n$ , where  $\tau_{(n)}$  is the  $n$ -tangle.*

The  $n$ -tangle was introduced in [28] as a measure of multipartite entanglement in  $n$ -qubits states that generalizes the Concurrence [54, 55]. The  $n$ -tangle of a pure

### Probabilistic Entanglement Concentration Protocol

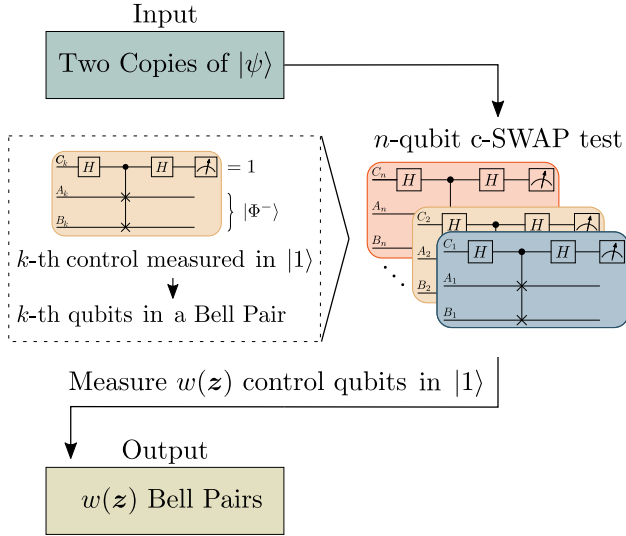

FIG. 2. **Protocol for concentrating entanglement.** Given two copies of  $|\psi\rangle$ , one can employ the  $n$ -qubit parallelized SWAP test to prepare Bell pairs between qubits in the different copies of  $|\psi\rangle$ . Specifically, measuring the  $k$ -th control qubit in the state  $|1\rangle$  implies that the joint state of the  $k$ -th qubit of each copy of  $|\psi\rangle$  is the Bell state  $|\Phi^-\rangle = \frac{1}{\sqrt{2}}(|01\rangle - |10\rangle)$ . Hence, a single run of the  $n$ -qubit parallelized SWAP test has a probability  $p(\mathbf{z})$  of concentrating the multipartite entanglement in the copies of  $|\psi\rangle$  and producing  $w(\mathbf{z})$  Bell pairs.

state  $|\psi\rangle$  is  $\tau_{(n)} = |\langle\psi|\tilde{\psi}\rangle|^2$ , with  $|\tilde{\psi}\rangle = \sigma_y^{\otimes n}|\psi^*\rangle$  where  $\sigma_y$  is the Pauli-Y operator, and  $|\psi^*\rangle$  is the conjugate of  $|\psi\rangle$ . Hence, for the special case of two-qubits one finds that  $C_{|\psi\rangle}(s) = \tau_{(2)}/4 = C^2/4$  for all  $s \in \mathcal{P}(\mathcal{S})$ , where here  $C$  denotes the Concurrence [54]. In general, we see from Proposition 5 that  $n$ -tangle is always one of the terms in the summation of Eq. (5), and hence is included in the Concentratable Entanglements.

Interestingly,  $p(\mathbf{z})$  can also be interpreted as the probability of concentrating the entanglement in the two copies of  $|\psi\rangle$  and “distilling” Bell pairs.

**Proposition 6.** *Given two copies of  $|\psi\rangle$ , if the  $k$ -th control qubit of the  $n$ -qubit parallelized SWAP test was measured in the state  $|1\rangle$ , then the joint post-measured state of the  $k$ -th qubits of each copy of  $|\psi\rangle$  is the Bell state  $|\Phi^-\rangle = \frac{1}{\sqrt{2}}(|01\rangle - |10\rangle)$ .*

Proposition 6 shows that when one measures (with probability  $p(\mathbf{z})$ ) a bitstring  $\mathbf{z}$  with (even) Hamming weight  $w(\mathbf{z})$ , then one has produced  $w(\mathbf{z})$  Bell pairs between qubits in the different copies of  $|\psi\rangle$  with indices in  $\mathcal{S}_h$ . This protocol is schematically shown in Fig. 2. In addition, Proposition 6 also sheds additional light on the Concentratable Entanglement  $C_{|\psi\rangle}(s)$  as the probability of obtaining any of the qubits pairs with labels in  $s$  in a Bell pair when performing a SWAP test.

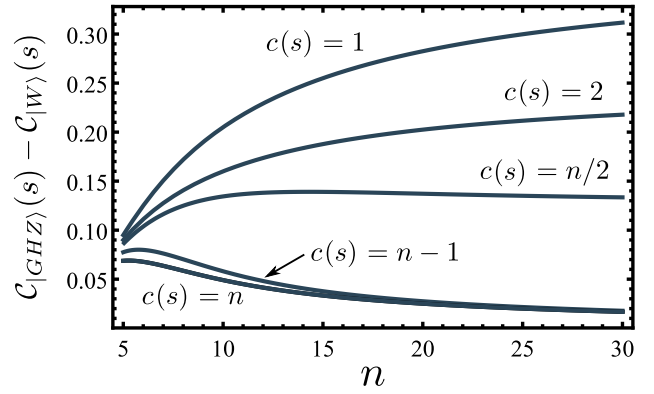

FIG. 3. **Comparison of the Concentratable Entanglements for  $GHZ$  and  $W$  states.** In the figure we show the difference  $C_{|GHZ\rangle}(s) - C_{|W\rangle}(s)$  versus the number of qubits  $n$  for different sets  $s$  with cardinalities  $c(s) = 1, 2, n/2, n-1, n$ . In all cases we find  $C_{|GHZ\rangle}(s) > C_{|W\rangle}(s)$ .

*Examples.* Let us now showcase how the probabilities  $p(\mathbf{z})$  and the Concentratable Entanglement can be used to characterize and quantify the multipartite entanglement in  $n$ -qubit  $W$  and  $GHZ$  states. First, let us consider the  $W$ -state  $|W\rangle = \frac{1}{\sqrt{n}} \sum_{\mathbf{x}:w(\mathbf{x})=1} |\mathbf{x}\rangle$ , i.e., the equal superposition of all states with Hamming weight equal to one. A direct calculation shows that  $p(\mathbf{z}) = \frac{1}{n^2}$  for all  $\mathbf{z}$  with  $w(\mathbf{z}) = 2$  and  $p(\mathbf{z}) = 0$  for all  $\mathbf{z}$  with  $w(\mathbf{z}) > 2$ . That is, in (5) one can only have terms where  $\mathbf{z}$  has only two ones. Concomitantly, when employing the  $n$ -qubit parallelized SWAP test one cannot concentrate the multipartite entanglement in  $|W\rangle$  to simultaneously produce more than two Bell pairs. Then, noting that for a given  $s$  there are  $\sum_{\mu=1}^{c(s)} \binom{n-\mu}{1} = c(s)(2n - c(s) - 1)/2$  non-zero terms in (5), one finds  $C_{|W\rangle}(s) = c(s)(2n - c(s) - 1)/2n^2$ .

On the other hand, consider the  $GHZ$  state  $|GHZ\rangle = \frac{1}{\sqrt{2}}(|\mathbf{0}\rangle + |\mathbf{1}\rangle)$ . We now find  $p(\mathbf{z}) = \frac{1}{2^n}$  for all  $\mathbf{z}$  with (even) Hamming weight  $w(\mathbf{z}) \geq 2$ . Unlike the  $W$ -state, when employing the  $n$ -qubit parallelized SWAP test one can obtain up to  $n$  simultaneous Bell pairs. In this case, given  $s$ , there are  $\sum_{\mu=1}^{c(s)} \sum_{\nu=1}^{(n-\mu+1)/2} \binom{n-\mu}{2\nu-1}$  non-zero terms in (5), leading to  $C_{|GHZ\rangle}(s) = \frac{1}{2} (1 - 1/(2^{c(s)-\delta_{c(s)n}}))$ , where the  $\delta_{c(s)n}$  arises from the fact that  $c(n) = n$  and  $c(n) = n-1$  have the same number of terms. Note that, as expected, both  $C_{|W\rangle}(s)$  and  $C_{|GHZ\rangle}(s)$  only depend on the cardinality of  $s$  and not on the actual indices in the set, as both states are invariant under permutations of the qubits.

We can now show that when  $s = \{j\}$  ( $c(s) = 1$ ), then  $C_{|W\rangle}(\{j\}) = \frac{n-1}{n^2}$  and  $C_{|GHZ\rangle}(\{j\}) = \frac{1}{4}$ . This implies that the bipartite entanglement of a single qubit in  $|W\rangle$  decreases with  $n$ , while on the other hand is constant for any  $n$ -qubit  $|GHZ\rangle$  state. Moreover, if  $s = \mathcal{S}$  ( $c(s) = n$ ), then  $C_{|W\rangle}(\mathcal{S}) = \frac{n-1}{2n}$  and  $C_{|GHZ\rangle}(\mathcal{S}) = \frac{1}{2} - \frac{1}{2^n}$ , and we recover the results in [42]. Note that for both cases considered one finds that  $C_{|GHZ\rangle}(s) > C_{|W\rangle}(s)$ , and hence

that the Concentratable Entanglements detect more multipartite entanglement in  $|GHZ\rangle$  than in  $|W\rangle$ . For  $s = \mathcal{S}$ , however, in the limit of  $n \rightarrow \infty$  both  $\mathcal{C}_{|GHZ\rangle}(s)$  and  $\mathcal{C}_{|W\rangle}(s)$  tend to the same value of  $\frac{1}{2}$ . Lastly, we note that a property of  $W$  states is that if one qubit is measured and projected out of the state, one can still measure entanglement in the ensuing state. Specifically, if one measures a qubit, then the concentratable entanglement will be equal to  $c(s)(2n - c(s) - 3)/2(n - 1)^2$  (to 0) with probability  $1 - 1/n^2$  ( $1/n^2$ ), as this corresponds to measuring the qubit in the zero (one) state. However, for  $GHZ$  states, projecting out just one qubit always yields a state with zero concentratable entanglement – confirming the well-known fact that while the  $W$  state is less entangled than the  $GHZ$ , it is more robust to noise.

In Fig. 3 we further analyze the difference  $\Delta\mathcal{C} = \mathcal{C}_{|GHZ\rangle}(s) - \mathcal{C}_{|W\rangle}(s)$  for different cardinalities of  $s$ . Here we see that for  $c(s) \leq n/2$ ,  $\Delta\mathcal{C}$  increases (or remains constant) as  $n$  increases implying that, again, small subsystems of qubits in  $|W\rangle$  contain less multipartite entanglement than those in  $|GHZ\rangle$ . For  $c(s) \sim n$ , the difference  $\Delta\mathcal{C}$  decreases as  $n$  increases, showing that the total multipartite entanglement is asymptotically the same for the two states.

*Conclusion.* In this work, we introduced a computable and operationally meaningful family of entanglement monotones called the Concentratable Entanglements. For a pure state  $|\psi\rangle$ , these quantities can be estimated on a quantum computer given two copies of  $|\psi\rangle$  via a parallelized SWAP test. We showed that they quantify and characterize the entanglement in and between subsystems of the composite quantum state in addition to quantifying global entanglement. We derived their operational meaning in terms of the probability of obtaining Bell pairs via the parallelized SWAP test. We also showed that well-known entanglement measures such

as the  $n$ -tangle, Concurrence, and linear entropy of entanglement are recovered as special cases of Concentratable Entanglements. As a special case of our results, we proved a conjecture from Ref. [42], which claimed that the parallelized SWAP test could be used to quantify and categorize pure state multipartite entanglement.

An important future direction will be to experimentally observe our entanglement measures on real quantum devices (e.g., using a quantum optical Fredkin gate [56]). A detailed analysis of the impact of hardware noise on the parallelized SWAP test will be useful for such implementations. As noise can turn pure states into mixed states, an additional important direction will be to generalize our entanglement measures (and their operational meaning) to mixed states. Finally, one could also analyze if a swap test with more copies of  $|\psi\rangle$  can provide further information beyond that in the Concentratable Entanglement.

### I. Acknowledgments

We thank Louis Schatzki for helpful discussions in deriving the continuity bound. This work was supported by the Quantum Science Center (QSC), a National Quantum Information Science Research Center of the U.S. Department of Energy (DOE). JLB was initially supported by the U.S. DOE through a quantum computing program sponsored by the LANL Information Science & Technology Institute. JLB was also supported by the National Science Foundation Graduate Research Fellowship under Grant No. 1650115. NG acknowledges support from the National Science Centre, Poland, under the SONATA project “Fundamental aspects of the quantum set of correlations”, Grant No. 2019/35/D/ST2/02014). PJC also acknowledges initial support from the LANL ASC Beyond Moore’s Law project. MC acknowledges initial support from the Center for Nonlinear Studies at Los Alamos National Laboratory (LANL).

- 
- [1] A. Einstein, B. Podolsky, and N. Rosen, “Can quantum-mechanical description of physical reality be considered complete?” *Phys. Rev.* **47**, 777–780 (1935).
  - [2] Mark M Wilde, *Quantum information theory* (Cambridge University Press, 2013).
  - [3] Martin B Plenio and Vlatko Vedral, “Entanglement in quantum information theory,” *arXiv preprint quant-ph/9804075* (1998), 10.1080/001075198181766.
  - [4] Ryszard Horodecki, Paweł Horodecki, Michał Horodecki, and Karol Horodecki, “Quantum entanglement,” *Reviews of modern physics* **81**, 865 (2009).
  - [5] N Gigena, Marco Di Tullio, and R Rossignoli, “One-body entanglement as a quantum resource in fermionic systems,” *Physical Review A* **102**, 042410 (2020).
  - [6] Charles H Bennett, Gilles Brassard, Claude Crépeau, Richard Jozsa, Asher Peres, and William K Wootters, “Teleporting an unknown quantum state via dual classical and einstein-podolsky-rosen channels,” *Physical Review Letters* **70**, 1895 (1993).
  - [7] Jonathan Barrett, “Nonsequential positive-operator-valued measurements on entangled mixed states do not always violate a bell inequality,” *Physical Review A* **65**, 042302 (2002).
  - [8] Richard Cleve and Harry Buhrman, “Substituting quantum entanglement for communication,” *Physical Review A* **56**, 1201 (1997).
  - [9] N Gigena and R Rossignoli, “Bipartite entanglement in fermion systems,” *Physical Review A* **95**, 062320 (2017).
  - [10] Artur K Ekert, “Quantum cryptography based on bell’s theorem,” *Physical Review Letters* **67**, 661 (1991).
  - [11] Nicolas Gisin, Grégoire Ribordy, Wolfgang Tittel, and Hugo Zbinden, “Quantum cryptography,” *Reviews of modern physics* **74**, 145 (2002).
  - [12] Artur Ekert and Richard Jozsa, “Quantum algorithms: entanglement-enhanced information processing,” *Philosophical Transactions of the Royal Society of London. Series A: Mathematical, Physical and Engineering Sciences* **356**, 1769–1782 (1998).

- [13] Michael A. Nielsen and Isaac L. Chuang, *Quantum Computation and Quantum Information* (Cambridge University Press, 2000).
- [14] Animesh Datta, Steven T Flammia, and Carlton M Caves, “Entanglement and the power of one qubit,” *Physical Review A* **72**, 042316 (2005).
- [15] Thomas Chalopin, Chayma Bouazza, Alexandre Evrard, Vasily Makhalov, Davide Dreon, Jean Dalibard, Leonid A Sidorenkov, and Sylvain Nascimbene, “Quantum-enhanced sensing using non-classical spin states of a highly magnetic atom,” *Nature communications* **9**, 1–8 (2018).
- [16] R. C. Pooser, N. Savino, E. Batson, J. L. Beckey, J. Garcia, and B. J. Lawrie, “Truncated nonlinear interferometry for quantum-enhanced atomic force microscopy,” *Phys. Rev. Lett.* **124**, 230504 (2020).
- [17] Luca Pezzè, “Entanglement-enhanced sensor networks,” *Nature Photonics* **15**, 74–76 (2021).
- [18] Sheng-Kai Liao, Wen-Qi Cai, Wei-Yue Liu, Liang Zhang, Yang Li, Ji-Gang Ren, Juan Yin, Qi Shen, Yuan Cao, Zheng-Ping Li, *et al.*, “Satellite-to-ground quantum key distribution,” *Nature* **549**, 43–47 (2017).
- [19] Xiao-Song Ma, Thomas Herbst, Thomas Scheidl, Daqing Wang, Sebastian Kropatschek, William Naylor, Bernhard Wittmann, Alexandra Mech, Johannes Kofler, Elena Anisimova, *et al.*, “Quantum teleportation over 143 kilometres using active feed-forward,” *Nature* **489**, 269–273 (2012).
- [20] Raju Valivarthi, Samantha I Davis, Cristián Peña, Si Xie, Nikolai Lauk, Lautaro Narváez, Jason P Allmaras, Andrew D Beyer, Yewon Gim, Meraj Hussein, *et al.*, “Teleportation systems toward a quantum internet,” *PRX Quantum* **1**, 020317 (2020).
- [21] Frank Arute, Kunal Arya, Ryan Babbush, Dave Bacon, *et al.*, “Quantum supremacy using a programmable superconducting processor,” *Nature* **574**, 505–510 (2019).
- [22] Karol Zyczkowski and Ingmar Bengtsson, “Geometry of quantum states,” (2006).
- [23] Michael Walter, David Gross, and Jens Eisert, “Multipartite entanglement,” *Quantum Information: From Foundations to Quantum Technology Applications*, 293–330 (2016).
- [24] Wolfgang Dür, Guilfo Vidal, and J Ignacio Cirac, “Three qubits can be entangled in two inequivalent ways,” *Physical Review A* **62**, 062314 (2000).
- [25] Valerie Coffman, Joydip Kundu, and William K Wootters, “Distributed entanglement,” *Physical Review A* **61**, 052306 (2000).
- [26] Antonio Acín, A Andrianov, L Costa, E Jané, JI Latorre, and Rolf Tarrach, “Generalized schmidt decomposition and classification of three-quantum-bit states,” *Physical Review Letters* **85**, 1560 (2000).
- [27] H Barnum and N Linden, “Monotones and invariants for multi-particle quantum states,” *Journal of Physics A: Mathematical and General* **34**, 6787 (2001).
- [28] Alexander Wong and Nelson Christensen, “Potential multipartite entanglement measure,” *Physical Review A* **63**, 044301 (2001).
- [29] David A Meyer and Nolan R Wallach, “Global entanglement in multiparticle systems,” *Journal of Mathematical Physics* **43**, 4273–4278 (2002).
- [30] Akimasa Miyake, “Classification of multipartite entangled states by multidimensional determinants,” *Physical Review A* **67**, 012108 (2003).
- [31] Géza Tóth and Otfried Gühne, “Detecting genuine multipartite entanglement with two local measurements,” *Physical Review Letters* **94**, 060501 (2005).
- [32] Michael Walter, Brent Doran, David Gross, and Matthias Christandl, “Entanglement polytopes: multiparticle entanglement from single-particle information,” *Science* **340**, 1205–1208 (2013).
- [33] Adam Sawicki, Michał Oszmaniec, and Marek Kuś, “Critical sets of the total variance can detect all stochastic local operations and classical communication classes of multiparticle entanglement,” *Phys. Rev. A* **86**, 040304 (2012).
- [34] Xueshi Guo, Casper R Breum, Johannes Borregaard, Shuro Izumi, Mikkel V Larsen, Tobias Gehring, Matthias Christandl, Jonas S Neergaard-Nielsen, and Ulrik L Andersen, “Distributed quantum sensing in a continuous-variable entangled network,” *Nature Physics* **16**, 281–284 (2020).
- [35] Daniel Gottesman, Thomas Jennewein, and Sarah Croke, “Longer-baseline telescopes using quantum repeaters,” *Physical Review Letters* **109**, 070503 (2012).
- [36] H Jeff Kimble, “The quantum internet,” *Nature* **453**, 1023–1030 (2008).
- [37] Miguel Navascués, Elie Wolfe, Denis Rosset, and Alejandro Pozas-Kerstjens, “Genuine network multipartite entanglement,” *Physical Review Letters* **125**, 240505 (2020).
- [38] Stephanie Wehner, David Elkouss, and Ronald Hanson, “Quantum internet: A vision for the road ahead,” *Science* **362** (2018), 10.1126/science.aam9288.
- [39] M. Cerezo, Andrew Arrasmith, Ryan Babbush, Simon C Benjamin, Suguru Endo, Keisuke Fujii, Jarrod R McClean, Kosuke Mitarai, Xiao Yuan, Lukasz Cincio, and Patrick J. Coles, “Variational quantum algorithms,” *arXiv preprint arXiv:2012.09265* (2020).
- [40] C Moura Alves and D Jaksch, “Multipartite entanglement detection in bosons,” *Physical Review Letters* **93**, 110501 (2004).
- [41] Graeme Smith, John A Smolin, Xiao Yuan, Qi Zhao, Davide Girolami, and Xiongfeng Ma, “Quantifying coherence and entanglement via simple measurements,” *arXiv preprint arXiv:1707.09928* (2017).
- [42] Steph Foulds, Viv Kendon, and Timothy P Spiller, “The controlled swap test for determining quantum entanglement,” *Quantum Science and Technology* (2021).
- [43] Patrick Hayden, Kevin Milner, and Mark M Wilde, “Two-message quantum interactive proofs and the quantum separability problem,” in *2013 IEEE Conference on Computational Complexity* (IEEE, 2013) pp. 156–167.
- [44] Gus Gutoski, Patrick Hayden, Kevin Milner, and Mark M Wilde, “Quantum interactive proofs and the complexity of separability testing,” *arXiv preprint arXiv:1308.5788* (2013).
- [45] Gavin K Brennen, “An observable measure of entanglement for pure states of multi-qubit systems,” *arXiv preprint quant-ph/0305094* (2003).
- [46] Harry Buhrman, Richard Cleve, John Watrous, and Ronald De Wolf, “Quantum fingerprinting,” *Physical Review Letters* **87**, 167902 (2001).
- [47] Aram W Harrow and Ashley Montanaro, “Testing product states, quantum merlin-arthur games and tensor optimization,” *Journal of the ACM (JACM)* **60**, 1–43 (2013).
- [48] Gus Gutoski, Patrick Hayden, Kevin Milner, and Mark M. Wilde, “Quantum interactive proofs and the

- complexity of separability testing,” *Theory of Computing* **11**, 59–103 (2015).
- [49] Lukasz Cincio, Yiğit Subaşı, Andrew T Sornborger, and Patrick J Coles, “Learning the quantum algorithm for state overlap,” *New Journal of Physics* **20**, 113022 (2018).
- [50] Yiğit Subaşı, Lukasz Cincio, and Patrick J Coles, “Entanglement spectroscopy with a depth-two quantum circuit,” *Journal of Physics A: Mathematical and Theoretical* **52**, 044001 (2019).
- [51] André R. R. Carvalho, Florian Mintert, and Andreas Buchleitner, “Decoherence and multipartite entanglement,” *Phys. Rev. Lett.* **93**, 230501 (2004).
- [52] See Supplementary Information, which contains Refs. [57–62].
- [53] A. J. Scott, “Multipartite entanglement, quantum-error-correcting codes, and entangling power of quantum evolutions,” *Phys. Rev. A* **69**, 052330 (2004).
- [54] William K Wootters, “Entanglement of formation of an arbitrary state of two qubits,” *Physical Review Letters* **80**, 2245 (1998).
- [55] Gregg Jaeger, Alexander V Sergienko, Bahaa EA Saleh, and Malvin C Teich, “Entanglement, mixedness, and spin-flip symmetry in multiple-qubit systems,” *Physical Review A* **68**, 022318 (2003).
- [56] Gerard J Milburn, “Quantum optical fredkin gate,” *Physical Review Letters* **62**, 2124 (1989).
- [57] Michael A. Nielsen and Guifré Vidal, “Majorization and the interconversion of bipartite states,” *Quantum Info. Comput.* **1**, 76–93 (2001).
- [58] M. A. Nielsen, “Conditions for a class of entanglement transformations,” *Phys. Rev. Lett.* **83**, 436–439 (1999).
- [59] Guifre Vidal, “Entanglement monotones,” *arXiv.org* (1999).
- [60] Dagmar Bruss and Gerd Leuchs, *Quantum information: from foundations to quantum technology applications* (Wiley-VCH, 2019).
- [61] Louis Schatzki, Andrew Arrasmith, Patrick J Coles, and M. Cerezo, “Manuscript in preparation,” (2021).
- [62] Patrick J Coles, M Cerezo, and Lukasz Cincio, “Strong bound between trace distance and hilbert-schmidt distance for low-rank states,” *Physical Review A* **100**, 022103 (2019).