



# CHORUS

This is the accepted manuscript made available via CHORUS. The article has been published as:

## Quantum Measurement Cooling

Lorenzo Buffoni, Andrea Solfanelli, Paola Verrucchi, Alessandro Cuccoli, and Michele Campisi

Phys. Rev. Lett. **122**, 070603 — Published 21 February 2019

DOI: [10.1103/PhysRevLett.122.070603](https://doi.org/10.1103/PhysRevLett.122.070603)

# Quantum Measurement Cooling

Lorenzo Buffoni,<sup>1,2</sup> Andrea Solfanelli,<sup>2</sup> Paola Verrucchi,<sup>3,2,4</sup> Alessandro Cuccoli,<sup>2,4</sup> and Michele Campisi<sup>2,4,5</sup>

<sup>1</sup>*Department of Information Engineering, University of Florence, via S. Marta 3, I-50139 Florence, Italy*

<sup>2</sup>*Department of Physics and Astronomy, University of Florence, via G. Sansone 1, I-50019 Sesto Fiorentino (FI), Italy*

<sup>3</sup>*Istituto dei Sistemi Complessi, Consiglio Nazionale delle Ricerche, via Madonna del Piano 10, I-50019 Sesto Fiorentino (FI), Italy*

<sup>4</sup>*INFN Sezione di Firenze, via G.Sansone 1, I-50019 Sesto Fiorentino (FI), Italy*

<sup>5</sup>*Kavli Institute for Theoretical Physics, University of California, Santa Barbara, CA 93106, USA*

Invasiveness of quantum measurements is a genuinely quantum mechanical feature that is not necessarily detrimental: Here we show how quantum measurements can be used to fuel a cooling engine. We illustrate quantum measurement cooling (QMeC) by means of a prototypical two-stroke engine which interacts with a measurement apparatus and two heat reservoirs at different temperatures. We show that feedback control is not necessary for operation while entanglement must be present in the measurement projectors. We quantify the probability that QMeC occurs when the measurement basis is chosen randomly, and find that it can be very large as compared to the probability of extracting energy (heat engine operation), while remaining always smaller than the most useless operation, namely dumping heat in both baths. These results show that QMeC can be very robust to experimental noise. A possible low-temperature solid-state implementation that integrates circuit QED technology with circuit QTD (quantum thermodynamics) technology is presented.

*Introduction.*— The second law of thermodynamics dictates that heat naturally flows from hot bodies to cold ones [1]. There are two standard ways to intervene and reverse the natural flow of heat (see Fig. 1): a) use work supplied by an external time-dependent driving force  $f(t)$  thus realising a standard refrigeration machine, see e.g., [2, 3]; b) implement a Maxwell demon that steers the heat by means of a feedback control loop, consisting in acquisition of information about the state  $|n\rangle$  of the working substance by means of non-invasive measurement, fol-

lowed by the timely application of various driving forces  $f_n(t)$ , depending on the measurement outcome, that do not do work on the system [4–6]. By non-invasive measurement here we mean that the measurement basis coincides with the basis in which the state of the measured system is diagonal (in the present work that is the energy eigenbasis). Here we will demonstrate yet another mechanism that is genuinely quantum mechanical, namely c) to use invasive quantum measurements as a resource, in fact a fuel, that powers refrigeration, without any feedback control. We shall call this mechanism “quantum measurement cooling” QMeC. QMeC is performed by a demon who needs not be intelligent. It rather needs to be knowledgeable, that is it has to know which measurement basis  $\{|\psi_k\rangle\}$  to employ in order that QMeC occurs.

While the idea of using measurement apparatus to fuel engines is currently emerging as a new paradigm in quantum thermodynamics [7–10], attention has never been posed before on whether it can be used for cooling, nor on the fact that, as we elucidate below, feedback control is not necessary for exploiting the quantum-measurement fuel. We address these questions by means of a thorough investigation of a prototypical two-qubit engine [2, 3, 5]. Our results shed new light on many facets of the second law of thermodynamics. For example, it emerges that in order for the device to work the measurement basis must contain entangled projectors, while maximal efficiency is achieved when the post measurement statistical mixture  $\rho'$  (see Eq. (4) below) is un-entangled. We also find that, when the measurement basis is chosen randomly, the least useful operation – i.e., dumping heat in both baths – is the most likely outcome (hence easier to realise in practice), which conforms to intuition. Also, while energy extraction is typically very unlikely, refrigeration can be very likely. This says that our demon needs not

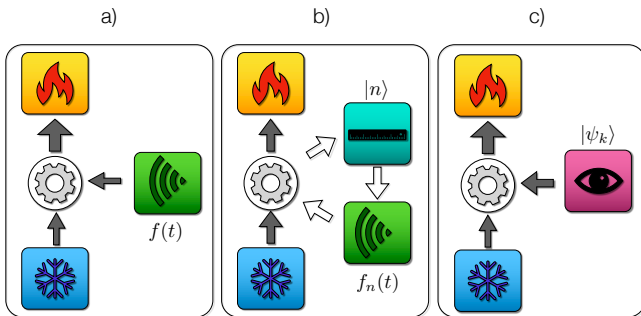

FIG. 1: Various ways to pump a heat current from a cold to a hot reservoir. a) In standard refrigeration the heat current is powered by energy injected by a time dependent driving force  $f(t)$ . b) In Maxwell demon refrigeration heat current is generated by a feedback loop where various driving forces  $f_n(t)$  are applied depending on the outcome,  $n$ , of non-invasive measurements on the working substance, without energy injection. c) In quantum measurement cooling, put forward here, the heat current is powered by energy provided via invasive measurements on an appropriate measurement basis  $\{|\psi_k\rangle\}$ , without performing feedback control. Filled arrows represent flow of energy.

be very knowledgeable in order to realise QMeC, or in more concrete terms, QMeC can be very robust to experimental noise, that is, it is practically feasible. In the following we shall comment on a possible experimental realisation.

*The model.*— Our model is a two-qubit engine [2, 3, 5, 11–13] see Fig. (2). Let

$$H_i = \frac{\hbar\omega_i}{2}\sigma_z^i \quad (1)$$

denote the Hamiltonian of qubit  $i$  expressed in terms of its Pauli matrix  $\sigma_z^i$  and its resonance frequency  $\omega_i$ . Let

$$H = H_1 + H_2 = \sum_n E_n \Pi_n \quad (2)$$

be the total Hamiltonian,  $E_n$  its eigenvalues with corresponding eigenprojectors  $\Pi_n = |n\rangle\langle n|$  and eigenvectors  $|n\rangle$ .

The two qubits are prepared each by thermal contact with a thermal bath at positive inverse temperatures  $\beta_1$  and  $\beta_2$  respectively, so that the initial state reads

$$\rho = \frac{e^{-\beta_1 H_1}}{Z_1} \otimes \frac{e^{-\beta_2 H_2}}{Z_2}, \quad (3)$$

where  $Z_i = \text{Tr} e^{-\beta_i H_i}$  is the canonical partition function. Without loss of generality we shall set  $0 < \beta_1 < \beta_2$  in what follows (bath 1 hotter than bath 2).

The quantum measurement cooling cycle is illustrated in Fig. (2). In the first stroke the two-qubit system interacts with a measurement apparatus, whose effect is to erase all coherences of the two qubit compound state in the measurement basis  $\{|\psi_k\rangle\}$ . In the following we shall focus for simplicity on the case of projective measurements onto 1-dimensional sub-spaces, pointing out on a case by case basis those results that have broader validity. Denoting the projectors onto the measurement basis as  $\pi_k = |\psi_k\rangle\langle\psi_k|$  the post-measurement state  $\rho'$  reads

$$\rho' = \Phi[\rho] = \sum_k \pi_k \rho \pi_k. \quad (4)$$

Let  $\langle\Delta E_i\rangle = \text{Tr} H_i (\Phi[\rho] - \rho)$  denote the change in the expectation value of energy of qubit  $i$ . Due to the property of  $\Phi$  of being a unital map [namely  $\Phi[\mathbb{1}] = \mathbb{1}$ ], it follows that [5]

$$\beta_1 \langle\Delta E_1\rangle + \beta_2 \langle\Delta E_2\rangle \geq 0, \quad (5)$$

which expresses the second law of thermodynamics.

In the second stroke each qubit is put back in contact with its thermal bath, which restores it to its initial Gibbs state and closes the cycle. Note that in the thermalisation stroke, on average, each qubit releases the energy  $\langle\Delta E_i\rangle$ , gained during the first stroke, to its respective bath. The  $\langle\Delta E_i\rangle$ 's represent therefore the heat exchanged with the two baths.

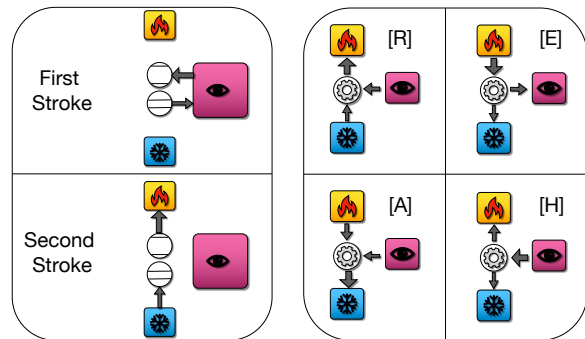

FIG. 2: Left Panel: Two-stroke two-qubit quantum measurement cooling. During the first stroke (top) the two qubits interact with the measurement apparatus, as a consequence qubit 1 receives energy ( $\langle\Delta E_1\rangle \geq 0$ ), while qubit 2 loses energy ( $\langle\Delta E_2\rangle \leq 0$ ) with an overall positive energy injection ( $\langle\Delta E_1\rangle + \langle\Delta E_2\rangle = \langle\Delta E\rangle \geq 0$ ). During the second stroke qubit 1 releases energy to the hot bath while qubit 2 withdraws energy from the cold bath. Right panel: the four possible operations allowed by the second law of thermodynamics, Eq. (5), and energy conservation.

The sum  $\langle\Delta E\rangle = \langle\Delta E_1\rangle + \langle\Delta E_2\rangle$  (sometimes referred to as “quantum heat” [14]) representing the energy given by the measurement apparatus is generally different from zero. Looking at the signs of the three energy exchanges  $\langle\Delta E\rangle$ ,  $\langle\Delta E_1\rangle$ ,  $\langle\Delta E_2\rangle$ , out of the 8 possible combinations only 4 are allowed by Eq. (5), the condition  $\langle\Delta E\rangle = \langle\Delta E_1\rangle + \langle\Delta E_2\rangle$ , and the condition  $0 < \beta_1 < \beta_2$ :

$$\begin{aligned} [\text{R}]: & \langle\Delta E_1\rangle \geq 0 \quad \langle\Delta E_2\rangle \leq 0 \quad \langle\Delta E\rangle \geq 0 \\ [\text{E}]: & \langle\Delta E_1\rangle \leq 0 \quad \langle\Delta E_2\rangle \geq 0 \quad \langle\Delta E\rangle \leq 0 \\ [\text{A}]: & \langle\Delta E_1\rangle \leq 0 \quad \langle\Delta E_2\rangle \geq 0 \quad \langle\Delta E\rangle \geq 0 \\ [\text{H}]: & \langle\Delta E_1\rangle \geq 0 \quad \langle\Delta E_2\rangle \geq 0 \quad \langle\Delta E\rangle \geq 0. \end{aligned} \quad (6)$$

They correspond to (see Fig. 2) [R] Refrigerator: heat flows from the cold bath to hot bath, with energy injection from the measurement apparatus; [E] energy Extraction (heat engine): part of the energy naturally flowing from the hot bath to the cold bath is derouted towards the measurement apparatus; [A] thermal Accelerator: the measurement apparatus provides energy to facilitate the natural flow from the hot bath to the cold bath; [H] Heater: both baths receive energy from the measurement apparatus. Which of the 4 possibilities is realised depends on the measurement basis  $\{|\psi_k\rangle\}$ . The above argument holds as well for higher rank projectors.

*Results.*— Our first main result is that depending on the problem parameters, some among the four possibilities, [R], [E], [A], [H], are excluded. In particular, for  $0 \leq \omega_2/\omega_1 \leq \beta_1/\beta_2$  only [R] and [H] are allowed. For  $\beta_1/\beta_2 \leq \omega_2/\omega_1 \leq 1$  only [E], [A], and [H] are allowed. For  $\omega_2/\omega_1 \geq 1$  only [A] and [H] are allowed. Note that the most useless operation, [H], may occur in the full parameter range. For simplicity we shall

call the range  $0 \leq \omega_2/\omega_1 \leq \beta_1/\beta_2$  the [R]-range, the range  $\beta_1/\beta_2 \leq \omega_2/\omega_1 \leq 1$  the [E]-range, and the range  $\omega_2/\omega_1 \geq 1$  the [A] range. In the Supplemental Material [15] we provide a proof and discuss how this result is related to the concept of ergotropy [21].

Our second main result is that, in the [E]-range, among all possible choices of measurement basis  $\{|\psi_k\rangle\}$ , the singlet-triplet basis

$$\begin{cases} |\psi_1^*\rangle = |\uparrow\uparrow\rangle; & |\psi_2^*\rangle = \frac{|\uparrow\downarrow\rangle + |\downarrow\uparrow\rangle}{\sqrt{2}} \\ |\psi_3^*\rangle = \frac{|\uparrow\downarrow\rangle - |\downarrow\uparrow\rangle}{\sqrt{2}}; & |\psi_4^*\rangle = |\downarrow\downarrow\rangle \end{cases} \quad (7)$$

maximises the energy extraction. This choice maximises as well the heat engine efficiency  $\eta^{[E]} = \langle\Delta E\rangle/\langle\Delta E_1\rangle$ . Similarly, in the [R]-range, the same choice of basis maximises the energy withdrawn from the cold bath  $-\langle\Delta E_2\rangle$  and the refrigeration efficiency  $\eta^{[R]} = -\langle\Delta E_2\rangle/\langle\Delta E\rangle$ . These results also show that the set of measurement-bases realising the [E] and [R] operations are not empty, that is energy extraction and quantum measurement cooling are possible. The proof is presented in [15].

As shown in [15] when a two-qudit working substance is considered the generic form of the optimal basis is such that it contains only factorised states of the type  $|a, a\rangle$  and pairs of entangled states of the type  $(|a, b\rangle \pm |c, d\rangle)/\sqrt{2}$ .

When the measurement basis is  $\{|\psi_k^*\rangle\}$ , the expression for the  $\langle\Delta E_i\rangle$ 's is

$$\langle\Delta E_{1,2}\rangle = \frac{\pm\omega_{1,2}}{2} \left( \frac{1}{1 + e^{\beta_1\omega_1}} - \frac{1}{1 + e^{\beta_2\omega_2}} \right), \quad (8)$$

that is half the value obtained when implementing standard refrigeration on the two-qubit engine by means of a full SWAP driving gate [2], which maximises standard refrigeration (or energy extraction, depending on the range) over all possible unitary gates [13],[15]. We note that the same energy exchanges in Eq. (8), hence maximal efficiency, can be obtained as well with higher rank projectors, e.g., with  $q_1 = |\psi_1^*\rangle\langle\psi_1^*| + |\psi_2^*\rangle\langle\psi_2^*|$ ,  $q_2 = |\psi_3^*\rangle\langle\psi_3^*| + |\psi_4^*\rangle\langle\psi_4^*|$ , or with  $q_1 = |\psi_2^*\rangle\langle\psi_2^*|$ ,  $q_2 = |\psi_1^*\rangle\langle\psi_1^*| + |\psi_3^*\rangle\langle\psi_3^*| + |\psi_4^*\rangle\langle\psi_4^*|$ .

In the general case of a working substance composed of two-qudits, in order for any operation other than [H] to occur some of the measurement projectors must be entangled, regardless of their rank [37]. However, this does not necessarily mean that the post-measurement state  $\rho'$ , which is a mixture of them, is an entangled one. Quite remarkably, it can rather be proved on general grounds [15] that thermodynamic efficiency is extremal at points where the post measurement state  $\rho'$  is diagonal in the  $\{|n\rangle\}$  basis, that is it has no entanglement. One can check that the  $\rho'$  resulting from the choice  $\{|\psi_k^*\rangle\}$  above is in fact diagonal in the  $\{|n\rangle\}$  basis.

Thirdly we have found the following. Imagine to pick the measurement basis  $\{|\psi_k\rangle\}$  randomly. Then, on average, the changes in the energy expectation value  $\langle\Delta E_i\rangle$

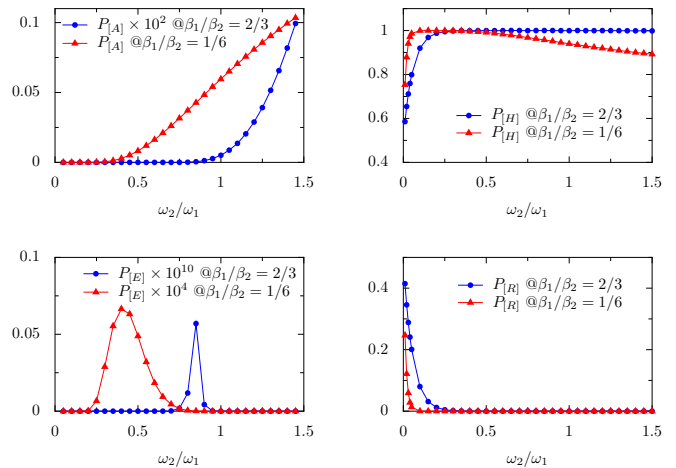

FIG. 3: Probability  $P_x$  of the various operations  $x = [A], [H], [E], [R]$  as function of level spacing ratio  $\omega_2/\omega_1$ , at two fixed value of temperature ratios  $\beta_1/\beta_2$ .

is non-negative, for both  $i = 1, 2$ :

$$\overline{\langle\Delta E_i\rangle} \geq 0, \quad (9)$$

where the overline denotes the average over the invariant measure of  $SU(4)$  (or more generally  $SU(N)$  when considering a larger working substance): picking a random basis  $\{|\psi_k\rangle\}$  is equivalent to picking a random unitary  $U: |\psi_k\rangle = U|k\rangle$ . That is, if choosing a random measurement basis, on average, the less useful operation, i.e. [H], is realised, independently of the choice of parameters. This means that, without any knowledge on what to do, one can only heat up everything [38]. This is in fact a general result that sheds light on an interesting facet of the second law. The general proof is presented in [15].

It follows that in order to realise QMeC, one needs to know which measurement basis to use. This then opens the question of what is the probability  $P_x$  that operation  $x$  (with  $x = [R], [E], [A], [H]$ ) is realised when picking a basis-change unitary  $U$  randomly from the invariant  $SU(4)$  measure. Said probability  $P_x$  is given by the ratio  $\mathcal{M}_x/\mathcal{M}$  of the volume  $\mathcal{M}_x$  of the subset of  $SU(4)$  that corresponds to  $[x]$ -operation rescaled by the total volume  $\mathcal{M}$  of the group. Volumes are calculated with respect to the invariant (Haar) measure of the group. To quantify it we have employed the parametrization of  $SU(4)$  in terms of generalised Euler angles  $\alpha = (\alpha_1, \alpha_2, \dots, \alpha_{15})$  [22] and have performed a uniform Monte Carlo sampling of the Euler angles. We remark that such sampling is not uniform with respect to the group invariant measure  $d\Omega(\alpha) = \mathcal{M}(\alpha)d\alpha$ : To achieve uniformity over said measure each point  $\alpha$  in the sample has to be weighted with the according factor  $\mathcal{M}(\alpha)$ . The results are reported in Fig. (3).

We firstly note that the Monte Carlo sampling confirms the results reported above, regarding the range of parameters associated to each operation. We also note that [H]

is always the most likely operation, regardless of the parameter range. The most surprising observation is that, while the probability  $P_{[E]}$  of [E]-operation, is extremely low, the probability of [R]-operation can be very large. In fact it tends to 1/2 from below as  $\omega_2/\omega_1 \rightarrow 0$ . This highlights an asymmetry between the [R] and [E] operations [39] having an important consequence: it shows that QMeC can be made more robust to noise by decreasing the ratio  $\omega_2/\omega_1$ . This is confirmed by our numerical study showing that the region of  $SU(4)$  for which QMeC is realised not only grows with decreasing  $\omega_2/\omega_1$  but also remains connected [15]. Thus experimental noise on the measurement basis is not an issue with respect to implementations. In contrast, the practical feasibility of the [E]-operation is greatly hindered by the fact that  $P_{[E]}$  is extremely small, hence it is extremely sensitive to experimental noise.

*Considerations about the experimental realisation.*— Quantum measurement cooling can be practically realised with solid-state superconducting circuitry by a suitable integration of circuit QED tools [23] and circuit Quantum Thermodynamics (circuit QTD) tools [24]. A possible design comprises two superconducting qubits coupled to an on-chip microwave line resonator [25]. Using the expression  $\pi_k = U\Pi_k U^\dagger$  in Eq. (4) to obtain  $\Phi[\rho] = \sum U\Pi_k U^\dagger \rho U\Pi_k U^\dagger$ , we see that the first stroke (measurement) dynamics can be implemented by the combination of two-state manipulation and standard measurement on the  $\{|n\rangle\}$  basis, as customarily done for two-qubit tomography [25]. That is: first the gate  $U^\dagger$  is applied, e.g. by driving two-photon side-band transitions [26]; Then, quantum-non-demolition measurement is applied in the  $\{|n\rangle\}$  basis by driving the cavity at the appropriate frequency [25]; Finally the gate  $U$  is applied, e.g., by driving two-photon side-band transitions [26]. The qubit level spacings can be manipulated by means of local magnetic fields, and cross-resonance techniques can be used to entangle them when far detuned [27, 28]. The output of the measurement can be inferred by reading the quadratures of the field transmitted through the resonant cavity [25]. The second stroke can be realised by inductively coupling each qubit to an on-chip resistor kept at inverse temperature  $\beta_i$  [5, 29, 30]. Heat exchanged with the resistors could be calorimetrically measured by means of fast on-chip thermometry of the resistors electron gas temperature [31, 32]

*Conclusions.*— We have presented a genuinely quantum mechanical cooling concept, whereby the fuel is the energy exchanged with a measurement apparatus performing invasive quantum measurements. No feedback control is necessary. We found a number of results valid in the case of a generic two-qudit working substance: a) in order for the engine to do anything useful the measurement basis must contain entangled projectors, while, quite paradoxically, best performance is achieved when the post measurement mixture  $\rho'$  is non-entangled; b)

lack of knowledge of how to operate the engine leads on average to heating up everything. Quite surprisingly in the special case of two-qubits, we have found that when choosing the measurement basis randomly, QMeC can be rather likely to occur (in contrast to energy extraction), which makes its implementation robust to experimental noise. While being aware that the issue of the energetic cost of ideal projective measurement is still an actively debated fundamental problem in measurement theory [33–36], two-qubit QMeC can be practically realised with superconducting circuitry by combination of circuit QED and circuit QTD (quantum thermodynamics) elements and methods.

*Acknowledgements.*— The authors wish to thank Ruggero Vaia, Stefano Gherardini and Benjamin Huard for useful comments. This research was supported in part by the National Science Foundation under Grant No. NSF PHY-1748958 and by the University of Florence in the framework of the University Strategic Project Program 2015 (project BRS00215).

- 
- [1] E. Fermi, *Thermodynamics* (Dover, New York, 1956).
  - [2] M. Campisi, R. Fazio, and J. P. Pekola, *New J. Phys.* **17**, 035012 (2015).
  - [3] M. Campisi and R. Fazio, *J. Phys. A: Math. Theo.* **49**, 345002 (2016).
  - [4] K. Maruyama, F. Nori, and V. Vedral, *Rev. Mod. Phys.* **81**, 1 (2009).
  - [5] M. Campisi, J. Pekola, and R. Fazio, *New J. Phys.* **19**, 053027 (2017).
  - [6] J. V. Koski, V. F. Maisi, T. Sagawa, and J. P. Pekola, *Phys. Rev. Lett.* **113**, 030601 (2014).
  - [7] X. Ding, J. Yi, Y. W. Kim, and P. Talkner, *Phys. Rev. E* **98**, 042122 (2018).
  - [8] R. Biele, C. A. Rodríguez-Rosario, T. Frauenheim, and A. Rubio, *npj Quantum Materials* **2**, 38 (2017).
  - [9] C. Elouard, D. Herrera-Martí, B. Huard, and A. Auffèves, *Phys. Rev. Lett.* **118**, 260603 (2017).
  - [10] C. Elouard and A. N. Jordan, *Phys. Rev. Lett.* **120**, 260601 (2018).
  - [11] S. Lloyd, *Phys. Rev. A* **56**, 3374 (1997).
  - [12] H. Quan, Y.-x. Liu, C. Sun, and F. Nori, *Phys. Rev. E* **76**, 031105 (2007).
  - [13] A. E. Allahverdyan, R. S. Johal, and G. Mahler, *Phys. Rev. E* **77**, 041118 (2008).
  - [14] C. Elouard, D. A. Herrera-Martí, M. Clusel, and A. Auffèves, *npj Quantum Information* **3** (2017).
  - [15] L. Buffoni, A. Solfanelli, P. Verrucchi, A. Cuccoli, and M. Campisi, *Quantum Measurement Cooling: Supplemental Material. It Includes Refs.* [16–20].
  - [16] A. W. Marshall, I. Olkin, and B. C. Arnold, *Inequalities: Theory of Majorization and its Applications*, vol. 143 (Springer, 2011), 2nd ed.
  - [17] I. Bengtsson, arXiv:0403088 (2004).
  - [18] L. van der Maaten, *t-SNE*, <https://lvdmaaten.github.io/tsne/> (2018).
  - [19] Y.H. Au-Yeung and C.M. Cheng, *Linear Algebra Its Appl.* **150**, (1991).

- [20] O. Chterental and D. Žoković, *Linear Algebra Its Appl.* **428**, 1178 (2008).
- [21] A. E. Allahverdyan, R. Balian, and Th. M. Nieuwenhuizen, *Europhys. Lett.* **67**, 565 (2004).
- [22] T. Tilma, M. Byrd, and E. C. G. Sudarshan, *J. Phys. A: Math. Gen.* **35**, 10445 (2002).
- [23] A. Blais, R.-S. Huang, A. Wallraff, S. M. Girvin, and R. J. Schoelkopf, *Phys. Rev. A* **69**, 062320 (2004).
- [24] J. P. Pekola, *Nat. Phys.* **11**, 118 (2015).
- [25] S. Filipp, P. Maurer, P. J. Leek, M. Baur, R. Bianchetti, J. M. Fink, M. Göppl, L. Steffen, J. M. Gambetta, A. Blais, et al., *Phys. Rev. Lett.* **102**, 200402 (2009).
- [26] P. J. Leek, S. Filipp, P. Maurer, M. Baur, R. Bianchetti, J. M. Fink, M. Göppl, L. Steffen, and A. Wallraff, *Phys. Rev. B* **79**, 180511 (2009).
- [27] G. S. Paraoanu, *Phys. Rev. B* **74**, 140504 (2006).
- [28] C. Rigetti and M. Devoret, *Phys. Rev. B* **81**, 134507 (2010).
- [29] A. O. Niskanen, Y. Nakamura, and J. P. Pekola, *Phys. Rev. B* **76**, 174523 (2007).
- [30] B. Karimi, J. P. Pekola, M. Campisi, and R. Fazio, *Quantum Sci. Technol.* **2**, 044007 (2017).
- [31] S. Gasparinetti, K. Viisanen, O.-P. Saira, T. Faivre, M. Arzeo, M. Meschke, and J. P. Pekola, *Phys. Rev. Applied* **3**, 014007 (2015).
- [32] L. B. Wang, O.-P. Saira, and J. P. Pekola, *App. Phys. Lett.* **112**, 013105 (2018).
- [33] Y. Guryanova, N. Friis, and M. Huber, arXiv:1805.11899 (2018).
- [34] P. Busch, P. Lahti, J.P. Pellonpää, and K. Ylino, *Quantum Measurement* (Springer, 2016).
- [35] S. Deffner, J.P. Paz, and W.H. Zurek, *Phys. Rev. E* **94**, 010103 (2016).
- [36] P. Kammerlander and J. Anders, *Sci. Rep.* **6**, 22174 (2016).
- [37] To see it consider the post measurement state  $\rho' = \sum_k \pi_k \rho \pi_k$  and note that it is a convex combination of the projectors  $\pi_k$ ,  $\rho' = \sum_k \pi_k r_k$ . If the projectors  $\pi_k$  are factorised  $\pi_k = \pi_{k_1}^1 \otimes \pi_{k_2}^2$ , physically it means that independent measurements are performed on each qubit. Since they start each in a thermal state, by applying similar argument as above for each single qubit, one obtains, in this case,  $\beta_i \langle \Delta E_i \rangle \geq 0$ , that is [H]-operation.
- [38] This result holds as well in the standard scenario where rather than interacting with a measurement apparatus, the system interacts with a classical field, and is accordingly described by a time-dependent Hamiltonian.
- [39] Rather we observe a symmetry between the [R] and [A] operations, associated to the exchange  $1 \leftrightarrow 2$  between hot and cold, with  $P_{[R]} \rightarrow 1/2$  as  $\omega_2/\omega_1 \rightarrow 0$  and  $P_{[A]} \rightarrow 1/2$  as  $\omega_1/\omega_2 \rightarrow 0$