



# CHORUS

This is the accepted manuscript made available via CHORUS. The article has been published as:

## Decoherence-Free Interaction between Giant Atoms in Waveguide Quantum Electrodynamics

Anton Frisk Kockum, Göran Johansson, and Franco Nori

Phys. Rev. Lett. **120**, 140404 — Published 5 April 2018

DOI: [10.1103/PhysRevLett.120.140404](https://doi.org/10.1103/PhysRevLett.120.140404)

# Decoherence-free interaction between giant atoms in waveguide QED

Anton Frisk Kockum,<sup>1,\*</sup> Göran Johansson,<sup>2</sup> and Franco Nori<sup>1,3</sup>

<sup>1</sup>*Center for Emergent Matter Science, RIKEN, Saitama 351-0198, Japan*

<sup>2</sup>*Department of Microtechnology and Nanoscience (MC2),*

*Chalmers University of Technology, SE-412 96 Gothenburg, Sweden*

<sup>3</sup>*Physics Department, The University of Michigan, Ann Arbor, Michigan 48109-1040, USA*

(Dated: March 5, 2018)

In quantum-optics experiments with both natural and artificial atoms, the atoms are usually small enough that they can be approximated as point-like compared to the wavelength of the electromagnetic radiation they interact with. However, superconducting qubits coupled to a meandering transmission line, or to surface acoustic waves, can realize “giant artificial atoms” that couple to a bosonic field at several points which are wavelengths apart. Here, we study setups with multiple giant atoms coupled at multiple points to a one-dimensional (1D) waveguide. We show that the giant atoms can be protected from decohering through the waveguide, but still have exchange interactions mediated by the waveguide. Unlike in decoherence-free subspaces, here the entire multi-atom Hilbert space ( $2^N$  states for  $N$  atoms) is protected from decoherence. This is not possible with “small” atoms. We further show how this decoherence-free interaction can be designed in setups with multiple atoms to implement, e.g., a 1D chain of atoms with nearest-neighbor couplings or a collection of atoms with all-to-all connectivity. This may have important applications in quantum simulation and quantum computing.

*Introduction.* In quantum systems, there is generally a fundamental problem of trade-off between interaction and protection from decoherence [1]. For spatially separated atoms, one way to realize a protected interaction is to use a quantum bus [2, 3]. As has been demonstrated in experiments [4–6], two atoms that are detuned from a resonator (the quantum bus) to which they both couple, can interact via virtual photons in the resonator. Since the photons mediating the interaction are virtual, this interaction is protected from losses in the resonator. Although this scheme can be extended to more atoms, and interactions between more than two atoms [7], there are limits to the connectivity between atoms and the protection from decoherence.

Another approach to protecting quantum information is decoherence-free subspaces [8, 9], i.e., particular subspaces (of the total Hilbert space of a quantum system) which are less sensitive to decoherence due to the form of their coupling to the dissipative environment. A well-known example is dark (sub-radiant) states [10], collective atomic states which do not decay, due to interference, to the environment that the atoms are all coupled to.

One platform where it has been suggested [11] that such decoherence-free subspaces could be used for protected quantum computation is waveguide quantum electrodynamics (QED). In waveguide QED, atoms are coupled to, and interact via, a continuum of bosonic modes in a one-dimensional (1D) waveguide. As reviewed in Refs. [12, 13], there are many experimental realizations of waveguide QED, including quantum dots and other emitters coupled to plasmons in nanowires [14, 15], quantum dots coupled to photonic crystal waveguides [16], and natural atoms coupled to optical fibers [17], but the platform with best performance is arguably superconducting artificial atoms [13, 18, 19] coupled to transmission lines,

where several experiments have been performed in the past few years [20–32]. There is also a wealth of theoretical work studying two [33–48] or more [11, 40, 49–61] atoms interacting with a 1D waveguide. For a more complete overview, see Refs. [12, 13].

Since the dark states in waveguide QED are a result of interference effects, it is relevant to explore schemes for increasing such interference. One such scheme is to terminate the waveguide with a mirror. A single atom in front of a mirror, a setup which has seen both experimental [29, 62–64] and theoretical [46, 48, 58, 65–71] investigation, can be protected from decay by interference between the relaxation from the atom and its mirror image.

An implicit assumption thus far has been that the atoms are *small* compared to the wavelengths of the bosonic modes of the waveguide they interact with (the wavelengths in question are those which correspond to the relevant atomic transition frequencies). However, interference effects can be further increased if the atoms can be *giant*, a term we take to mean that the atoms can couple to the waveguide at several points, which can be spaced wavelengths apart. The physics of a single such giant atom has been explored recently [72, 73] with results including a frequency-dependent relaxation rate and Lamb shift. These works were inspired by recent experiments [74–79] realizing giant atoms by coupling superconducting artificial atoms to surface acoustic waves (SAWs), which have much shorter wavelengths than the microwaves normally used in experiments with such artificial atoms. However, as outlined in Ref. [72] (and utilized in Ref. [80]), superconducting transmission lines could be used to achieve the same effect if they are suitably meandered.

In this Letter, we present the first study of multiple

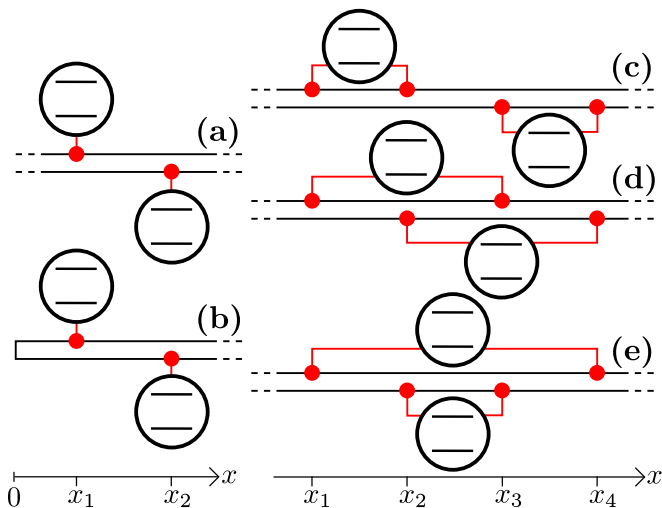

Figure 1. Sketches of (a) two small atoms coupled to an open transmission line, (b) two small atoms coupled to a semi-infinite transmission line, (c) two separate giant atoms, (d) two braided giant atoms, and (e) two nested giant atoms. Red circles denote connection points. The atom with the leftmost connection point is denoted  $a$  and the other  $b$ .

giant atoms coupled to a 1D waveguide. We begin by considering the case of two giant atoms, coupled at two points each to an open waveguide, and compare this setup to two small atoms in open and semi-infinite waveguides. We show that, for a certain arrangement of the connection points of the giant atoms, decoherence into the waveguide can be *completely suppressed* while the giant atoms *still interact* with each other via the waveguide. Unlike the dark states for small atoms, this decoherence-free interaction is independent of the states of the giant atoms, i.e., the *entire* multi-atom Hilbert space is protected from decoherence, not just a subspace.

We then generalize these results to an arbitrary number of giant atoms with an arbitrary number of connection points each. In this way, we show that protected pairwise exchange interactions between multiple giant atoms can be *designed* for high connectivity (beyond nearest neighbor) and with *arbitrary sign* of the coupling strengths. We outline how these setups can be implemented with superconducting circuits.

We believe that these results can find many applications, e.g., in quantum simulation [81, 82], where there is much interest in spins connected in one- or two-dimensional arrangements [47, 83–89]. It may also be possible to use setups with giant atoms to generate entangled states such as cluster [90] or graph [91] states, which can be used for one-way quantum computing [92–94].

*Master equation for two atoms in a waveguide.* We begin by comparing setups with two small (i.e., only coupled at a single point) atoms in an open [Fig. 1(a)] or semi-infinite [Fig. 1(b)] waveguide to setups with two

giant atoms coupled to an open waveguide at two connection points each. As shown in Fig. 1(c)–(e), there are three distinct topologies for the positions of the connection points in this case. We call the topology in Fig. 1(c) separate giant atoms, the one in Fig. 1(d) braided giant atoms, and the one in Fig. 1(e) nested giant atoms. For simplicity, we limit the discussion in this Letter to atoms with two levels (qubits).

Tracing out the continuum of bosonic modes in the waveguide, a master equation for the density matrix  $\rho$  of the atoms can be derived, assuming weak coupling at each connection point and negligible travel time between connection points. We use the SLH formalism [95–98] for cascaded quantum systems [99–101] to show [102] that the master equation for all setups in Fig. 1 can be written as

$$\begin{aligned} \dot{\rho} = & -i \left[ \omega'_a \frac{\sigma_z^a}{2} + \omega'_b \frac{\sigma_z^b}{2} + g(\sigma_-^a \sigma_+^b + \sigma_+^a \sigma_-^b), \rho \right] \\ & + \Gamma_a \mathcal{D}[\sigma_-^a] \rho + \Gamma_b \mathcal{D}[\sigma_-^b] \rho \\ & + \Gamma_{\text{coll}} \left[ \left( \sigma_-^a \rho \sigma_+^b - \frac{1}{2} \{ \sigma_+^a \sigma_-^b, \rho \} \right) + \text{H.c.} \right], \quad (1) \end{aligned}$$

where  $\omega'_j = \omega_j + \delta\omega_j$ ,  $\omega_j$  is the transition frequency of atom  $j$  only including Lamb shifts from individual connection points,  $\delta\omega_j$  is the contribution to the Lamb shift of atom  $j$  from interference between connection points,  $\mathcal{D}[A]\rho = A\rho A^\dagger - \frac{1}{2}\{A^\dagger A, \rho\}$ ,  $g$  is the strength of the exchange interaction between the atoms,  $\sigma_+^j$  ( $\sigma_-^j$ ) is the raising (lowering) operator of atom  $j$ ,  $\sigma_z^j$  is a Pauli matrix for atom  $j$ ,  $\Gamma_j$  is the individual relaxation rate of atom  $j$ ,  $\Gamma_{\text{coll}}$  is the collective relaxation rate for the atoms, and H.c. denotes Hermitian conjugate.

For the case of small atoms in an open waveguide, the coefficients in Eq. (1) are already well known [33, 40, 57]. In Table I, we compare these coefficients with those that result for the other setups in Fig. 1. For simplicity, we assume here that the distance between subsequent connection points is identical, and that  $\omega_a \approx \omega_b$ , such that the phase acquired traveling from one connection point to the next is  $\varphi = k|x_{j+1} - x_j|$ , where the wavenumber  $k = \omega_a/v$ , with  $v$  the velocity of the modes in the waveguide (for the setup with a mirror,  $\varphi = 2kx_1$ ). We also assume that the bare relaxation rate (the relaxation rate before any interference effects are taken into account) at each connection point is  $\gamma$ . Expressions for arbitrary bare relaxation rates and arbitrary phase shifts between connection points are given in [102].

We plot the relaxation rates and coupling strengths from Table I as functions of  $\varphi$  in Fig. 2. For small atoms in an open waveguide, we note that the individual relaxation rates  $\Gamma_j \neq 0 \forall \varphi$ . For this setup, there is only a certain superposition state, the dark state, that is protected from decoherence [40]. For all other setups, there are values of  $\varphi$  where  $\Gamma_j = 0$ . Furthermore, at the points where  $\Gamma_j = 0$ ,  $\Gamma_{\text{coll}} = 0$  also holds. Thus, these setups can

| Setup                | Frequency shift $\delta\omega_j$                                | Exchange interaction $g$  | Individual decay $\Gamma_j$                             | Collective decay $\Gamma_{\text{coll}}$                  |
|----------------------|---|---|---|--|
| Small atoms          | 0   | $\frac{\gamma}{2} \sin \varphi$                                     | $\gamma$  | $\gamma \cos \varphi$                                    |
| Small atoms + mirror | $\frac{\gamma}{2} \sin \varphi; \frac{\gamma}{2} \sin 3\varphi$ | $\frac{\gamma}{2} (\sin \varphi + \sin 2\varphi)$                   | $\gamma(1 + \cos \varphi); \gamma(1 + \cos 3\varphi)$   | $\gamma(\cos \varphi + \cos 2\varphi)$                   |
| Separate giant atoms | $\gamma \sin \varphi$   | $\frac{\gamma}{2} (\sin \varphi + 2 \sin 2\varphi + \sin 3\varphi)$ | $2\gamma(1 + \cos \varphi)$                             | $\gamma(\cos \varphi + 2 \cos 2\varphi + \cos 3\varphi)$ |
| Braided giant atoms  | $\gamma \sin 2\varphi$  | $\frac{\gamma}{2} (3 \sin \varphi + \sin 3\varphi)$                 | $2\gamma(1 + \cos 2\varphi)$                            | $\gamma(3 \cos \varphi + \cos 3\varphi)$                 |
| Nested giant atoms   | $\gamma \sin 3\varphi; \gamma \sin \varphi$                     | $\gamma(\sin \varphi + \sin 2\varphi)$                              | $2\gamma(1 + \cos 3\varphi); 2\gamma(1 + \cos \varphi)$ | $2\gamma(\cos \varphi + \cos 2\varphi)$                  |

Table I. Frequency shifts, exchange interaction strengths, and decoherence rates for the setups from Fig. 1. In fields with two entries, the first corresponds to atom  $a$  and the second to atom  $b$ .

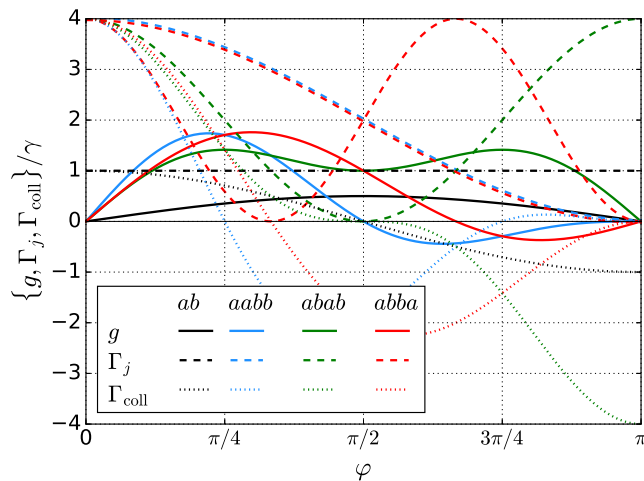

Figure 2. Exchange interaction (solid lines) and decoherence rates (individual: dashed lines; collective: dotted lines) as a function of  $\varphi$  for the setups in Fig. 1. The corresponding expressions are given in Table I. The labels  $ab$  (small atoms, black),  $aabb$  (separate giant atoms, blue),  $abab$  (braided giant atoms, green), and  $abba$  (nested giant atoms, red) correspond to the ordering of connection points for the two atoms. The case of small atoms in a semi-infinite waveguide [Fig. 1(b)] is not plotted separately, since it is qualitatively equivalent to the case of nested giant atoms. Note that there are two red dashed lines, one for  $\Gamma_a$  and one for  $\Gamma_b$ .

protect all system states from decoherence. In contrast, for small atoms only a single superposition state can be protected from decoherence by making the  $\Gamma_j$  and  $\Gamma_{\text{coll}}$  terms cancel for the lowering operator of that state [40].

The implications of  $\Gamma_j = 0$  for  $g$  differ for the setups where it can occur. Only in the case of braided giant atoms is it possible to have  $g \neq 0$  when  $\Gamma_j = 0 \forall j$ , i.e., a decoherence-free interaction. This can be understood as follows:  $\Gamma_j = 0$  implies that the phase acquired traveling between the connection points of atom  $j$  is  $(2n+1)\pi$  for some integer  $n$ . The collective decay is set by interference between emission from connection points belonging to different atoms, but the sum of these contributions will be zero when the emission from two connection points of one atom interfere destructively. The exchange interaction is set by emission from connection points of one atom being absorbed at connection points of the other atom.

For separate and nested giant atoms, the emission from the two connection points belonging to atom  $b$  will cancel if  $\Gamma_b = 0$ , but in the case of *braided* giant atoms, the two inner connection points are placed in-between the two connection points of the other atom, so the contributions from the two connection points of the other atom need *not* interfere destructively. In [102], we show that all these conclusions about implications of  $\Gamma_j = 0$  for the various setups *remain unchanged* even if we allow for arbitrary bare relaxation rates at each connection point and arbitrary distances (but still negligible travel time) between connection points.

*Generalization to multiple giant atoms with multiple connection points.* We now consider the most general setup possible, with  $N$  atoms such that atom  $j$  has  $M_j$  connection points and the bare relaxation rate at connection point  $j_n$  of atom  $j$  is  $\gamma_{j_n}$ . The phase acquired traveling from connection point  $j_n$  of atom  $j$  to connection point  $k_m$  of atom  $k$  is  $\varphi_{j_n, k_m}$ . With the same assumptions as before, we extend our derivation in the SLH formalism to obtain the master equation [102]

$$\begin{aligned}
 \dot{\rho} = & -i \left[ \sum_{j=1}^N \omega'_j \frac{\sigma_z^{(j)}}{2} + \sum_{j=1}^{N-1} \sum_{k=j+1}^N g_{j,k} \left( \sigma_-^{(j)} \sigma_+^{(k)} + \sigma_+^{(j)} \sigma_-^{(k)} \right), \rho \right] \\
 & + \sum_{j=1}^N \Gamma_j \mathcal{D} \left[ \sigma_-^{(j)} \right] \rho \\
 & + \sum_{j=1}^{N-1} \sum_{k=j+1}^N \Gamma_{\text{coll},j,k} \left[ \left( \sigma_-^{(j)} \rho \sigma_+^{(k)} - \frac{1}{2} \left\{ \sigma_+^{(j)} \sigma_-^{(k)}, \rho \right\} \right) + \text{H.c.} \right],
 \end{aligned} \tag{2}$$

where now  $\delta\omega_j = \sum_{n=1}^{M_j-1} \sum_{m=n+1}^{M_j} \sqrt{\gamma_{j_n} \gamma_{j_m}} \sin \varphi_{j_n, j_m}$ , the exchange interaction between atoms  $j$  and  $k$  is  $g_{j,k} = \sum_{n=1}^{M_j} \sum_{m=1}^{M_k} \frac{\sqrt{\gamma_{j_n} \gamma_{k_m}}}{2} \sin \varphi_{j_n, k_m}$ ,  $\Gamma_j = \sum_{n=1}^{M_j} \sum_{m=1}^{M_j} \sqrt{\gamma_{j_n} \gamma_{j_m}} \cos \varphi_{j_n, j_m}$ , and the collective decay rate for atoms  $j$  and  $k$  is  $\Gamma_{\text{coll},j,k} = \sum_{n=1}^{M_j} \sum_{m=1}^{M_k} \sqrt{\gamma_{j_n} \gamma_{k_m}} \cos \varphi_{j_n, k_m}$ .

Since all interactions in Eq. (2) are pairwise, the intuition gained from studying the case of two giant atoms with two connection points goes a long way in explaining the properties of these more general setups. If all connection points of atom  $j$  are to the left (or right) of all connection points of atom  $k$ , we call this pair of atoms

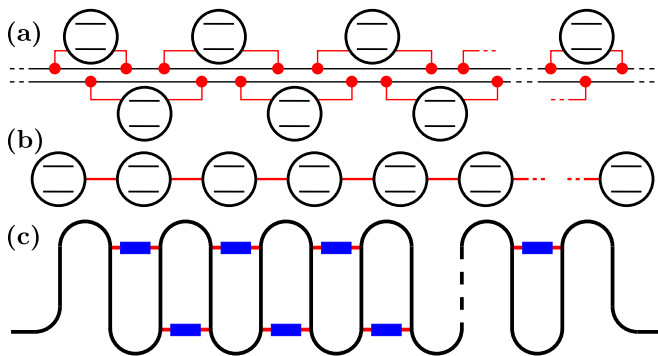

Figure 3. Sketch of a setup with giant atoms realizing a 1D chain of qubits with protected nearest-neighbor couplings. (a) The layout of the connection points. (b) The effective system. (c) A possible implementation with superconducting circuits. The black line is a transmission line, the blue blocks are qubits, and the red lines mark where the qubits couple to the transmission line.

separate. If all connection points of atom  $j$  are situated in-between two subsequent connection points of atom  $k$ , we call this pair of atoms nested. All other setups are braided. Using the same reasoning as above, we can show that  $\Gamma_j = \Gamma_k = 0$  implies both  $\Gamma_{\text{coll},j,k} = 0$  and  $g_{j,k} = 0$  for separate and nested atoms, but  $g_{j,k} \neq 0$  is possible if the atoms are braided [102].

*1D spin chain with protected, designed nearest-neighbor couplings.* We now discuss two setups with protected pairwise atom-atom interactions that can be realized with multiple giant atoms. The first setup is a 1D chain of atoms with nearest-neighbor couplings, shown in Fig. 3. With the arrangement of connection points given in Fig. 3(a), each pair of neighboring atoms is in a braided configuration, which allows decoherence-free interaction within each such pair, effectively leading to the 1D chain of atoms shown in Fig. 3(b). All other pairs of atoms are *not* braided, and will thus *not* interact when  $\Gamma_j = 0 \forall j$ . In Fig. 3(c), we show how this setup could be implemented with superconducting qubits coupled to a meandering transmission line. Note that there is space for individual readout and control lines to be connected to each qubit in this setup. The decay that such additional channels would introduce can easily be kept small. Furthermore, such control lines could both perform single-qubit rotations and tune the transition frequencies of the qubits. Tuning the qubits in and out of resonance with each other is one way to turn the qubit-qubit coupling on and off to implement two-qubit gates [13]. With more connection points, we can arrange for the detuned transition frequencies to also be protected from decay [72].

If the 1D chain in Fig. 3 contains  $N$  giant atoms with two connection points each, there will be  $2N - 1$  phases between subsequent connection points. Implementing the constraint  $\Gamma_j = 0 \forall j$  will fix  $N$  of these phases. There are then  $N - 1$  pairwise couplings, set by one phase each:

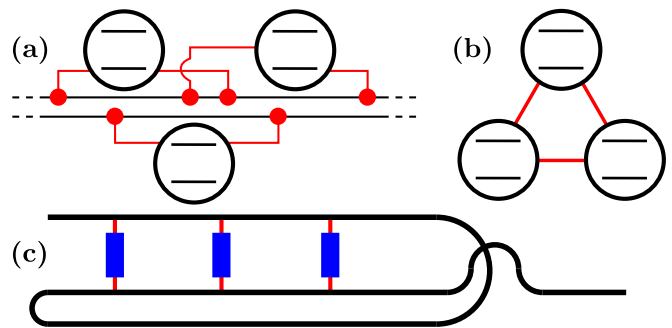

Figure 4. Sketch of a setup with three giant atoms realizing a protected all-to-all coupling. (a) The layout of the connection points. (b) The effective system. (c) A possible implementation with superconducting circuits. The symbols used are the same as in Fig. 3.

$g_{j,j+1} = \sqrt{\gamma_{(j+1)_1}\gamma_{j_2}} \sin \varphi_{(j+1)_1,j_2}$  [102]. We thus have *maximal freedom* in designing the decoherence-free interactions (both amplitude and sign) in this setup.

*High connectivity for multiple giant atoms.* Our second example is a setup with three atoms with a protected all-to-all connectivity, shown in Fig. 4. With the arrangement of connection points given in Fig. 4(a), each pair of neighboring atoms is in a braided configuration, which allows decoherence-free interaction within each such pair, effectively leading to the triangular arrangement of coupled atoms shown in Fig. 3(b). In Fig. 3(c), we show how this setup could be implemented with superconducting circuits. Unlike the previous example, this setup requires the transmission line to cross itself at least once, but this can be solved with air bridges [103]. Note that it is straightforward to extend this setup to all-to-all connectivity with more atoms by simply adding more superconducting qubits to the row in Fig. 3(c). However, when making  $N$  large in the setups in Figs. 3 and 4, care must still be taken that the travel time between connection points remains negligible. This is more important for the setup in Fig. 4 because of the greater connectivity.

For the setup in Fig. 4, and its generalization to  $N$  atoms, the condition  $\Gamma_j = 0 \forall j$  sets  $N$  constraints, which leaves  $N - 1$  free parameters (phases) to determine the amplitudes of  $N(N - 1)/2$  pairwise couplings. The individual coupling strengths can thus be chosen quite freely, but not completely freely. In the case  $N = 3$ , we show in [102] how all couplings can be set to have the same amplitude while their signs can be chosen freely.

*Summary and outlook.* We have derived a master equation for multiple giant atoms coupled to a 1D waveguide at multiple points, which can be spaced wavelengths apart. We have shown that such giant atoms, with connection points in a braided configuration, can realize a phenomenon that is impossible with small atoms: a *nonzero exchange interaction* mediated by the waveguide between pairs of atoms that are *protected from decoherence* into the waveguide, *regardless* of the atomic state.

We have furthermore shown that setups with giant atoms are ready to be implemented in superconducting circuits, and that this could be used for quantum simulation of coupled spins.

This work opens up many interesting directions for future research. Phenomena that have been studied for waveguide QED with small atoms, e.g., sub- and super-radiance (dark and bright states), chiral propagation [104, 105], interaction between atoms with more than two levels, and 2D baths [106–108], should be revisited to determine whether giant atoms lead to new effects.

*Acknowledgements.* We acknowledge useful discussions with Lingzhen Guo, Per Delsing, Daniel Campbell, William Oliver, and Simone Gasparinetti. A.F.K. acknowledges support from a JSPS Postdoctoral Fellowship for Overseas Researchers (P15750). G.J. acknowledges financial support from the Swedish Research Council and the Knut and Alice Wallenberg Foundation. F.N. acknowledges support from the RIKEN iTHES Project, the MURI Center for Dynamic Magneto-Optics via the AFOSR award number FA9550-14-1-0040, the Japan Society for the Promotion of Science (KAKENHI), the IMPACT program of JST, JSPS-RFBR grant No. 17-52-50023, CREST grant No. JPMJCR1676, the RIKEN-AIST “Challenge Research” program, and the Sir John Templeton Foundation.

---

\* e-mail:anton.frisk.kockum@gmail.com

- [1] D. Suter and G. A. Álvarez, “Colloquium: Protecting quantum information against environmental noise,” *Rev. Mod. Phys.* **88**, 041001 (2016).
- [2] S.-B. Zheng and G.-C. Guo, “Efficient Scheme for Two-Atom Entanglement and Quantum Information Processing in Cavity QED,” *Phys. Rev. Lett.* **85**, 2392 (2000).
- [3] A. Blais, J. Gambetta, A. Wallraff, D. I. Schuster, S. M. Girvin, M. H. Devoret, and R. J. Schoelkopf, “Quantum-information processing with circuit quantum electrodynamics,” *Phys. Rev. A* **75**, 032329 (2007), arXiv:0612038 [cond-mat].
- [4] S. Osnaghi, P. Bertet, A. Auffeves, P. Maioli, M. Brune, J. M. Raimond, and S. Haroche, “Coherent Control of an Atomic Collision in a Cavity,” *Phys. Rev. Lett.* **87**, 037902 (2001), arXiv:0105063 [quant-ph].
- [5] J. Majer, J. M. Chow, J. M. Gambetta, J. Koch, B. R. Johnson, J. A. Schreier, L. Frunzio, D. I. Schuster, A. A. Houck, A. Wallraff, A. Blais, M. H. Devoret, S. M. Girvin, and R. J. Schoelkopf, “Coupling superconducting qubits via a cavity bus,” *Nature* **449**, 443 (2007), arXiv:0709.2135.
- [6] S. Filipp, M. Göppl, J. M. Fink, M. Baur, R. Bianchetti, L. Steffen, and A. Wallraff, “Multimode mediated qubit-qubit coupling and dark-state symmetries in circuit quantum electrodynamics,” *Phys. Rev. A* **83**, 063827 (2011), arXiv:1011.3732.
- [7] R. Stassi, V. Macrì, A. F. Kockum, O. Di Stefano, A. Miranowicz, S. Savasta, and F. Nori, “Quantum non-linear optics without photons,” *Phys. Rev. A* **96**, 023818 (2017), arXiv:1702.00660.
- [8] D. A. Lidar, I. L. Chuang, and K. B. Whaley, “Decoherence-Free Subspaces for Quantum Computation,” *Phys. Rev. Lett.* **81**, 2594 (1998), arXiv:9807004 [quant-ph].
- [9] D. A. Lidar, *Quantum Information and Computation for Chemistry*, edited by Sabre Kais, Advances in Chemical Physics (John Wiley & Sons, Inc., Hoboken, New Jersey, 2014) p. 295, arXiv:1208.5791.
- [10] R. H. Dicke, “Coherence in Spontaneous Radiation Processes,” *Phys. Rev.* **93**, 99 (1954).
- [11] V. Paulisch, H. J. Kimble, and A. González-Tudela, “Universal quantum computation in waveguide QED using decoherence free subspaces,” *New J. Phys.* **18**, 043041 (2016), arXiv:1512.04803.
- [12] D. Roy, C. M. Wilson, and O. Firstenberg, “Colloquium: Strongly interacting photons in one-dimensional continuum,” *Rev. Mod. Phys.* **89**, 021001 (2017), arXiv:1603.06590.
- [13] X. Gu, A. F. Kockum, A. Miranowicz, Y.-X. Liu, and F. Nori, “Microwave photonics with superconducting quantum circuits,” *Phys. Rep.* **718-719**, 1–102 (2017), arXiv:1707.02046.
- [14] A. V. Akimov, A. Mukherjee, C. L. Yu, D. E. Chang, A. S. Zibrov, P. R. Hemmer, H. Park, and M. D. Lukin, “Generation of single optical plasmons in metallic nanowires coupled to quantum dots,” *Nature* **450**, 402 (2007).
- [15] A. Huck and U. L. Andersen, “Coupling single emitters to quantum plasmonic circuits,” *Nanophotonics* **5**, 1 (2016), arXiv:1604.00846.
- [16] M. Arcari, I. Söllner, A. Javadi, S. Lindskov Hansen, S. Mahmoodian, J. Liu, H. Thyrrerstrup, E. H. Lee, J. D. Song, S. Stobbe, and P. Lodahl, “Near-Unity Coupling Efficiency of a Quantum Emitter to a Photonic Crystal Waveguide,” *Phys. Rev. Lett.* **113**, 093603 (2014), arXiv:1402.2081.
- [17] M. Bajcsy, S. Hofferberth, V. Balic, T. Peyronel, M. Hafezi, A. S. Zibrov, V. Vuletic, and M. D. Lukin, “Efficient All-Optical Switching Using Slow Light within a Hollow Fiber,” *Phys. Rev. Lett.* **102**, 203902 (2009), arXiv:0901.0336.
- [18] J. Q. You and F. Nori, “Superconducting circuits and quantum information,” *Phys. Today* **58**, 42 (2005).
- [19] J. Q. You and F. Nori, “Atomic physics and quantum optics using superconducting circuits,” *Nature* **474**, 589 (2011), arXiv:1202.1923.
- [20] O. Astafiev, A. M. Zagoskin, A. A. Abdumalikov, Y. A. Pashkin, T. Yamamoto, K. Inomata, Y. Nakamura, and J. S. Tsai, “Resonance Fluorescence of a Single Artificial Atom,” *Science* **327**, 840 (2010), arXiv:1002.4944.
- [21] O. V. Astafiev, A. A. Abdumalikov, A. M. Zagoskin, Y. A. Pashkin, Y. Nakamura, and J. S. Tsai, “Ultimate On-Chip Quantum Amplifier,” *Phys. Rev. Lett.* **104**, 183603 (2010), arXiv:1004.3864.
- [22] A. A. Abdumalikov, O. Astafiev, A. M. Zagoskin, Y. A. Pashkin, Y. Nakamura, and J. S. Tsai, “Electromagnetically Induced Transparency on a Single Artificial Atom,” *Phys. Rev. Lett.* **104**, 193601 (2010), arXiv:1004.2306.
- [23] I.-C. Hoi, C. M. Wilson, G. Johansson, T. Palomaki, B. Peropadre, and P. Delsing, “Demonstration of a Single-Photon Router in the Microwave Regime,” *Phys. Rev. Lett.* **107**, 073601 (2011), arXiv:1103.1782.

- [24] A. A. Abdumalikov, O. V. Astafiev, Y. A. Pashkin, Y. Nakamura, and J. S. Tsai, “Dynamics of coherent and incoherent emission from an artificial atom in a 1D space,” *Phys. Rev. Lett.* **107**, 043604 (2011), [arXiv:1101.5542](#).
- [25] I.-C. Hoi, T. Palomaki, J. Lindkvist, G. Johansson, P. Delsing, and C. M. Wilson, “Generation of Non-classical Microwave States Using an Artificial Atom in 1D Open Space,” *Phys. Rev. Lett.* **108**, 263601 (2012), [arXiv:1201.2269](#).
- [26] A. F. van Loo, A. Fedorov, K. Lalumiere, B. C. Sanders, A. Blais, and A. Wallraff, “Photon-Mediated Interactions Between Distant Artificial Atoms,” *Science* **342**, 1494 (2013), [arXiv:1407.6747](#).
- [27] I.-C. Hoi, A. F. Kockum, T. Palomaki, T. M. Stace, B. Fan, L. Tornberg, S. R. Sathyamoorthy, G. Johansson, P. Delsing, and C. M. Wilson, “Giant Cross-Kerr Effect for Propagating Microwaves Induced by an Artificial Atom,” *Phys. Rev. Lett.* **111**, 053601 (2013), [arXiv:1207.1203](#).
- [28] I.-C. Hoi, C. M. Wilson, G. Johansson, J. Lindkvist, B. Peropadre, T. Palomaki, and P. Delsing, “Microwave quantum optics with an artificial atom in one-dimensional open space,” *New J. Phys.* **15**, 025011 (2013), [arXiv:1210.4303](#).
- [29] I.-C. Hoi, A. F. Kockum, L. Tornberg, A. Pourkabirian, G. Johansson, P. Delsing, and C. M. Wilson, “Probing the quantum vacuum with an artificial atom in front of a mirror,” *Nat. Phys.* **11**, 1045 (2015), [arXiv:1410.8840](#).
- [30] Y. Liu and A. A. Houck, “Quantum electrodynamics near a photonic bandgap,” *Nat. Phys.* **13**, 48 (2017), [arXiv:1603.02998](#).
- [31] P. Forn-Díaz, J. J. García-Ripoll, B. Peropadre, J.-L. Orgiazzi, M. A. Yurtalan, R. Belyansky, C. M. Wilson, and A. Lupascu, “Ultrastrong coupling of a single artificial atom to an electromagnetic continuum in the nonperturbative regime,” *Nat. Phys.* **13**, 39 (2017), [arXiv:1602.00416](#).
- [32] P. Y. Wen, A. F. Kockum, H. Ian, J. C. Chen, F. Nori, and I.-C. Hoi, “Reflective Amplification without Population Inversion from a Strongly Driven Superconducting Qubit,” *Phys. Rev. Lett.* **120**, 063603 (2018), [arXiv:1707.06400](#).
- [33] R. H. Lehmburg, “Radiation from an N-Atom System. II. Spontaneous Emission from a Pair of Atoms,” *Phys. Rev. A* **2**, 889 (1970).
- [34] P. W. Milonni and P. L. Knight, “Retardation in the resonant interaction of two identical atoms,” *Phys. Rev. A* **10**, 1096 (1974).
- [35] L. Zhou, H. Dong, Y.-X. Liu, C. P. Sun, and F. Nori, “Quantum supercavity with atomic mirrors,” *Phys. Rev. A* **78**, 063827 (2008), [arXiv:0809.4063](#).
- [36] S. Rist, J. Eschner, M. Hennrich, and G. Morigi, “Photon-mediated interaction between two distant atoms,” *Phys. Rev. A* **78**, 013808 (2008), [arXiv:0805.0655](#).
- [37] G.-Y. Chen, N. Lambert, C.-H. Chou, Y.-N. Chen, and F. Nori, “Surface plasmons in a metal nanowire coupled to colloidal quantum dots: Scattering properties and quantum entanglement,” *Phys. Rev. B* **84**, 045310 (2011).
- [38] A. Gonzalez-Tudela, D. Martin-Cano, E. Moreno, L. Martin-Moreno, C. Tejedor, and F. J. Garcia-Vidal, “Entanglement of Two Qubits Mediated by One-Dimensional Plasmonic Waveguides,” *Phys. Rev. Lett.* **106**, 020501 (2011), [arXiv:1010.5048](#).
- [39] K. Xia, M. Macovei, and J. Evers, “Stationary entanglement in strongly coupled qubits,” *Phys. Rev. B* **84**, 184510 (2011), [arXiv:1107.1587](#).
- [40] K. Lalumière, B. C. Sanders, A. F. van Loo, A. Fedorov, A. Wallraff, and A. Blais, “Input-output theory for waveguide QED with an ensemble of inhomogeneous atoms,” *Phys. Rev. A* **88**, 043806 (2013), [arXiv:1305.7135](#).
- [41] H. Zheng and H. U. Baranger, “Persistent Quantum Beats and Long-Distance Entanglement from Waveguide-Mediated Interactions,” *Phys. Rev. Lett.* **110**, 113601 (2013), [arXiv:1206.4442](#).
- [42] S. Derouault and M. A. Bouchene, “One-photon wave packet interacting with two separated atoms in a one-dimensional waveguide: Influence of virtual photons,” *Phys. Rev. A* **90**, 023828 (2014), [arXiv:1404.4513](#).
- [43] F. Fratini, E. Mascarenhas, L. Safari, J.-P. Poizat, D. Valente, A. Auffèves, D. Gerace, and M. F. Santos, “Fabry-Perot Interferometer with Quantum Mirrors: Nonlinear Light Transport and Rectification,” *Phys. Rev. Lett.* **113**, 243601 (2014), [arXiv:1410.5972](#).
- [44] M. Laakso and M. Pletyukhov, “Scattering of Two Photons from Two Distant Qubits: Exact Solution,” *Phys. Rev. Lett.* **113**, 183601 (2014), [arXiv:1406.1664](#).
- [45] E. Shahmoon, I. Mazets, and G. Kurizki, “Giant vacuum forces via transmission lines,” *Proc. Natl. Acad. Sci.* **111**, 10485 (2014), [arXiv:1304.2028](#).
- [46] Y.-L. L. Fang and H. U. Baranger, “Waveguide QED: Power spectra and correlations of two photons scattered off multiple distant qubits and a mirror,” *Phys. Rev. A* **91**, 053845 (2015), [arXiv:1502.03803](#).
- [47] J. S. Douglas, T. Caneva, and D. E. Chang, “Photon Molecules in Atomic Gases Trapped Near Photonic Crystal Waveguides,” *Phys. Rev. X* **6**, 031017 (2016), [arXiv:1511.00816](#).
- [48] H. Pichler and P. Zoller, “Photonic Circuits with Time Delays and Quantum Feedback,” *Phys. Rev. Lett.* **116**, 093601 (2016), [arXiv:1510.04646](#).
- [49] R. H. Lehmburg, “Radiation from an N-Atom System. I. General Formalism,” *Phys. Rev. A* **2**, 883 (1970).
- [50] R. Friedberg, S.R. Hartmann, and J.T. Manassah, “Frequency shifts in emission and absorption by resonant systems of two-level atoms,” *Phys. Rep.* **7**, 101 (1973).
- [51] T. S. Tsoi and C. K. Law, “Quantum interference effects of a single photon interacting with an atomic chain inside a one-dimensional waveguide,” *Phys. Rev. A* **78**, 063832 (2008).
- [52] D. E. Chang, L. Jiang, A. V. Gorshkov, and H. J. Kimble, “Cavity QED with atomic mirrors,” *New J. Phys.* **14**, 063003 (2012), [arXiv:1201.0643](#).
- [53] K. Stannigel, P. Rabl, and P. Zoller, “Driven-dissipative preparation of entangled states in cascaded quantum-optical networks,” *New J. Phys.* **14**, 063014 (2012), [arXiv:1112.1690](#).
- [54] T. Ramos, H. Pichler, A. J. Daley, and P. Zoller, “Quantum Spin Dimers from Chiral Dissipation in Cold-Atom Chains,” *Phys. Rev. Lett.* **113**, 237203 (2014), [arXiv:1408.4357](#).
- [55] S. R. Sathyamoorthy, L. Tornberg, A. F. Kockum, B. Q. Baragiola, J. Combes, C. M. Wilson, T. M. Stace, and G. Johansson, “Quantum Nondemolition Detection of a Propagating Microwave Photon,” *Phys. Rev. Lett.* **112**,

- 093601 (2014), arXiv:1308.2208.
- [56] Y.-L. L. Fang, H. Zheng, and H. U. Baranger, “One-dimensional waveguide coupled to multiple qubits: photon-photon correlations,” *EPJ Quantum Technol.* **1**, 3 (2014), arXiv:1308.6551.
- [57] H. Pichler, T. Ramos, A. J. Daley, and P. Zoller, “Quantum Optics of Chiral Spin Networks,” *Phys. Rev. A* **91**, 042116 (2015), arXiv:1411.2963.
- [58] T. Shi, D. E. Chang, and J. I. Cirac, “Multiphoton-scattering theory and generalized master equations,” *Phys. Rev. A* **92**, 053834 (2015), arXiv:1507.08699.
- [59] P.-O. Guimond, A. Roulet, H. N. Le, and V. Scarani, “Rabi oscillation in a quantum cavity: Markovian and non-Markovian dynamics,” *Phys. Rev. A* **93**, 023808 (2016), arXiv:1505.07908.
- [60] I. M. Mirza and J. C. Schotland, “Multiqubit entanglement in bidirectional-chiral-waveguide QED,” *Phys. Rev. A* **94**, 012302 (2016), arXiv:1604.03646.
- [61] A. González-Tudela, V. Paulisch, H. J. Kimble, and J. I. Cirac, “Efficient Multiphoton Generation in Waveguide Quantum Electrodynamics,” *Phys. Rev. Lett.* **118**, 213601 (2017), arXiv:1603.01243.
- [62] J. Eschner, C. Raab, F. Schmidt-Kaler, and R. Blatt, “Light interference from single atoms and their mirror images,” *Nature* **413**, 495 (2001).
- [63] M. A. Wilson, P. Bushev, J. Eschner, F. Schmidt-Kaler, C. Becher, R. Blatt, and U. Dorner, “Vacuum-Field Level Shifts in a Single Trapped Ion Mediated by a Single Distant Mirror,” *Phys. Rev. Lett.* **91**, 213602 (2003), arXiv:0306159 [quant-ph].
- [64] F. Dubin, D. Rotter, M. Mukherjee, C. Russo, J. Eschner, and R. Blatt, “Photon Correlation versus Interference of Single-Atom Fluorescence in a Half-Cavity,” *Phys. Rev. Lett.* **98**, 183003 (2007), arXiv:0610065 [quant-ph].
- [65] D. Meschede, W. Jhe, and E. A. Hinds, “Radiative properties of atoms near a conducting plane: An old problem in a new light,” *Phys. Rev. A* **41**, 1587 (1990).
- [66] U. Dorner and P. Zoller, “Laser-driven atoms in half-cavities,” *Phys. Rev. A* **66**, 023816 (2002).
- [67] A. Beige, J. Pachos, and H. Walther, “Spontaneous emission of an atom in front of a mirror,” *Phys. Rev. A* **66**, 063801 (2002).
- [68] H. Dong, Z. R. Gong, H. Ian, L. Zhou, and C. P. Sun, “Intrinsic cavity QED and emergent quasinormal modes for a single photon,” *Phys. Rev. A* **79**, 063847 (2009), arXiv:0805.3085.
- [69] K. Koshino and Y. Nakamura, “Control of the radiative level shift and linewidth of a superconducting artificial atom through a variable boundary condition,” *New J. Phys.* **14**, 043005 (2012).
- [70] Y. Wang, J. Minár, G. Hétet, and V. Scarani, “Quantum memory with a single two-level atom in a half cavity,” *Phys. Rev. A* **85**, 013823 (2012), arXiv:1111.4261.
- [71] T. Tufarelli, F. Ciccarello, and M. S. Kim, “Dynamics of spontaneous emission in a single-end photonic waveguide,” *Phys. Rev. A* **87**, 013820 (2013), arXiv:1208.0969.
- [72] A. F. Kockum, P. Delsing, and G. Johansson, “Designing frequency-dependent relaxation rates and Lamb shifts for a giant artificial atom,” *Phys. Rev. A* **90**, 013837 (2014), arXiv:1406.0350.
- [73] L. Guo, A. L. Grimsmo, A. F. Kockum, M. Pletyukhov, and G. Johansson, “Giant acoustic atom: A single quantum system with a deterministic time delay,” *Phys. Rev. A* **95**, 053821 (2017), arXiv:1612.00865.
- [74] M. V. Gustafsson, T. Aref, A. F. Kockum, M. K. Ekström, G. Johansson, and P. Delsing, “Propagating phonons coupled to an artificial atom,” *Science* **346**, 207 (2014), arXiv:1404.0401.
- [75] T. Aref, P. Delsing, M. K. Ekström, A. F. Kockum, M. V. Gustafsson, G. Johansson, P. J. Leek, E. Magnusson, and R. Manenti, “Quantum Acoustics with Surface Acoustic Waves,” in *Superconducting Devices in Quantum Optics*, edited by R. H. Hadfield and G. Johansson (Springer, 2016) arXiv:1506.01631.
- [76] R. Manenti, A. F. Kockum, A. Patterson, T. Behrle, J. Rahamim, G. Tancredi, F. Nori, and P. J. Leek, “Circuit quantum acoustodynamics with surface acoustic waves,” *Nat. Commun.* **8**, 975 (2017), arXiv:1703.04495.
- [77] A. Noguchi, R. Yamazaki, Y. Tabuchi, and Y. Nakamura, “Qubit-Assisted Transduction for a Detection of Surface Acoustic Waves near the Quantum Limit,” *Phys. Rev. Lett.* **119**, 180505 (2017), arXiv:1710.00467.
- [78] A. N. Bolgar, J. I. Zotova, D. D. Kirichenko, I. S. Besedin, A. V. Semenov, R. S. Shaikhaidarov, and O. V. Astafiev, “Experimental demonstration of a two-dimensional phonon cavity in the quantum regime,” (2017), arXiv:1710.06476.
- [79] B. A. Moores, L. R. Sletten, J. J. Viennot, and K. W. Lehnert, “Cavity quantum acoustic device in the multimode strong coupling regime,” (2017), arXiv:1711.05913.
- [80] A. Ciani and D. P. DiVincenzo, “Three-qubit direct dispersive parity measurement with tunable coupling qubits,” *Phys. Rev. B* **96**, 214511 (2017), arXiv:1708.04175.
- [81] I. Buluta and F. Nori, “Quantum Simulators,” *Science* **326**, 108 (2009).
- [82] I. M. Georgescu, S. Ashhab, and F. Nori, “Quantum simulation,” *Rev. Mod. Phys.* **86**, 153 (2014), arXiv:1308.6253.
- [83] R. F. Wang, C. Nisoli, R. S. Freitas, J. Li, W. McConville, B. J. Cooley, M. S. Lund, N. Samarth, C. Leighton, V. H. Crespi, and P. Schiffer, “Artificial ‘spin ice’ in a geometrically frustrated lattice of nanoscale ferromagnetic islands,” *Nature* **439**, 303 (2006), arXiv:0601429 [cond-mat].
- [84] R. Islam, C. Senko, W. C. Campbell, S. Korenblit, J. Smith, A. Lee, E. E. Edwards, C.-C. J. Wang, J. K. Freericks, and C. Monroe, “Emergence and Frustration of Magnetism with Variable-Range Interactions in a Quantum Simulator,” *Science* **340**, 583 (2013).
- [85] Y. Salathé, M. Mondal, M. Oppliger, J. Heinsoo, P. Kurpiers, A. Potočnik, A. Mezzacapo, U. Las Heras, L. Lamata, E. Solano, S. Filipp, and A. Wallraff, “Digital Quantum Simulation of Spin Models with Circuit Quantum Electrodynamics,” *Phys. Rev. X* **5**, 021027 (2015), arXiv:1502.06778.
- [86] T. Giamarchi, “One-dimensional physics in the 21st century,” *Comptes Rendus Phys.* **17**, 322 (2016).
- [87] H. Bernien, S. Schwartz, A. Keesling, H. Levine, A. Omran, H. Pichler, S. Choi, A. S. Zibrov, M. Endres, M. Greiner, V. Vuletić, and M. D. Lukin, “Probing many-body dynamics on a 51-atom quantum simulator,” *Nature* **551**, 579 (2017), arXiv:1707.04344.
- [88] K. Cedergren, R. Ackroyd, S. Kafanov, N. Vogt, A. Shnirman, and T. Duty, “Insulating Josephson Junction Chains as Pinned Luttinger Liquids,” *Phys. Rev.*



- Lett.* **119**, 167701 (2017), arXiv:1702.04386.
- [89] B. Yang, Y.-Y. Chen, Y.-G. Zheng, H. Sun, H.-N. Dai, X.-W. Guan, Z.-S. Yuan, and J.-W. Pan, “Quantum criticality and the Tomonaga-Luttinger liquid in one-dimensional Bose gases,” *Phys. Rev. Lett.* **119**, 165701 (2017), arXiv:1611.00426.
- [90] H. J. Briegel and R. Raussendorf, “Persistent Entanglement in Arrays of Interacting Particles,” *Phys. Rev. Lett.* **86**, 910 (2001), arXiv:0004051 [quant-ph].
- [91] M. Hein, J. Eisert, and H. J. Briegel, “Multiparty entanglement in graph states,” *Phys. Rev. A* **69**, 062311 (2004), arXiv:0307130 [quant-ph].
- [92] R. Raussendorf and H. J. Briegel, “A One-Way Quantum Computer,” *Phys. Rev. Lett.* **86**, 5188 (2001).
- [93] P. Walther, K. J. Resch, T. Rudolph, E. Schenck, H. Weinfurter, V. Vedral, M. Aspelmeyer, and A. Zeilinger, “Experimental one-way quantum computing,” *Nature* **434**, 169 (2005).
- [94] H. J. Briegel, D. E. Browne, W. Dür, R. Raussendorf, and M. Van den Nest, “Measurement-based quantum computation,” *Nat. Phys.* **5**, 19 (2009), arXiv:0910.1116.
- [95] J. Gough and M. R. James, “Quantum Feedback Networks: Hamiltonian Formulation,” *Commun. Math. Phys.* **287**, 1109 (2009), arXiv:0804.3442.
- [96] J. Gough and M. R. James, “The Series Product and Its Application to Quantum Feedforward and Feedback Networks,” *IEEE Trans. Automat. Contr.* **54**, 2530 (2009), arXiv:0707.0048.
- [97] J. Combes, J. Kerckhoff, and M. Sarovar, “The SLH framework for modeling quantum input-output networks,” *Adv. Phys. X* **2**, 784 (2017), arXiv:1611.00375.
- [98] J. Zhang, Y.-X. Liu, R.-B. Wu, K. Jacobs, and F. Nori, “Quantum feedback: Theory, experiments, and applications,” *Phys. Rep.* **679**, 1 (2017), arXiv:1407.8536.
- [99] C. W. Gardiner, “Driving a quantum system with the output field from another driven quantum system,” *Phys. Rev. Lett.* **70**, 2269 (1993).
- [100] H. J. Carmichael, “Quantum trajectory theory for cascaded open systems,” *Phys. Rev. Lett.* **70**, 2273 (1993).
- [101] C. W. Gardiner and P. Zoller, *Quantum Noise*, 3rd ed. (Springer, 2004).
- [102] Supplementary Material.
- [103] D. Ristè, S. Poletto, M.-Z. Huang, A. Bruno, V. Vesterinen, O.-P. Saira, and L. DiCarlo, “Detecting bit-flip errors in a logical qubit using stabilizer measurements,” *Nat. Commun.* **6**, 6983 (2015), arXiv:1411.5542.
- [104] K. Y. Bliokh, F. J. Rodríguez-Fortuño, F. Nori, and A. V. Zayats, “Spin-orbit interactions of light,” *Nat. Photonics* **9**, 796 (2015), arXiv:1505.02864.
- [105] P. Lodahl, S. Mahmoodian, S. Stobbe, A. Rauschenbeutel, P. Schneeweiss, J. Volz, H. Pichler, and P. Zoller, “Chiral quantum optics,” *Nature* **541**, 473 (2017), arXiv:1608.00446.
- [106] A. González-Tudela and J. I. Cirac, “Quantum Emitters in Two-Dimensional Structured Reservoirs in the Nonperturbative Regime,” *Phys. Rev. Lett.* **119**, 143602 (2017), arXiv:1705.06673.
- [107] A. González-Tudela and J. I. Cirac, “Markovian and non-Markovian dynamics of quantum emitters coupled to two-dimensional structured reservoirs,” *Phys. Rev. A* **96**, 043811 (2017), arXiv:1705.06677.
- [108] J. Perczel, J. Borregaard, D. E. Chang, H. Pichler, S. F. Yelin, P. Zoller, and M. D. Lukin, “Photonic band structure of two-dimensional atomic lattices,” *Phys. Rev. A* **96**, 063801 (2017), arXiv:1708.03413.