



# CHORUS

This is the accepted manuscript made available via CHORUS. The article has been published as:

## Cascade model of wave turbulence

Wonjung Lee, Gregor Kovačič, and David Cai

Phys. Rev. E **97**, 062140 — Published 21 June 2018

DOI: [10.1103/PhysRevE.97.062140](https://doi.org/10.1103/PhysRevE.97.062140)

# Cascade model of wave turbulence

Wonjung Lee,<sup>1,\*</sup> Gregor Kovačič,<sup>2</sup> and David Cai<sup>3,4,5</sup>

<sup>1</sup>*Department of Mathematics, City University of Hong Kong, Tat Chee Avenue, Kowloon Tong, Hong Kong*

<sup>2</sup>*Mathematical Sciences Department, Rensselaer Polytechnic Institute, 110 8th Street, Troy, NY 12180, USA*

<sup>3</sup>*Courant Institute of Mathematical Sciences and Center for Neural Science,  
New York University, New York, NY 10012, USA*

<sup>4</sup>*Department of Mathematics, MOE-LSC, and Institute of Natural Sciences,  
Shanghai Jiao Tong University, Shanghai 200240, China*

<sup>5</sup>*NYUAD Institute, New York University Abu Dhabi,  
P.O. Box 129188, Abu Dhabi, United Arab Emirates*

We propose a *cascade* model of wave turbulence designed to simplify the study of this phenomenon in the way that shell models simplify the study of Navier-Stokes turbulence. The model consists of resonant quartets, in which some modes are driven and damped, and others shared by pairs of quartets and transferring energy between them, mimicking the natural energy transfer mechanism in weakly-turbulent waves. A set of detailed-balance conditions singles out the case of the cascade model in equilibrium, for which we can explicitly derive a Gaussian equilibrium measure and a maximum-entropy principle using a Kolmogorov forward equation. Away from equilibrium, we can approximate the second-moment dynamics of the mode amplitudes using kinetic equations. In a non-equilibrium steady state, we can also approximate the higher moments of the driven-damped mode amplitudes, and characterize the distribution of the shared-mode amplitudes as Gaussian. For this latter distribution, we find an information-theoretic argument, akin to entropy maximization, which lets us conclude that arbitrary initial shared-mode amplitude distributions approach Gaussian form in forward time. The cascade model may provide insight into mechanisms governing weakly-turbulent wave systems and perhaps afford computational savings as compared to direct numerical simulations of the corresponding wave-like equations.

PACS numbers: 47.27.eb, 47.27.ek, 52.35.Mw, 05.20.Dd

Keywords: Turbulence, shell model, resonance quartet, inertial range, energy cascade

## I. INTRODUCTION

Turbulence presents one of the most challenging problems in theoretical and computational physics and applied mathematics. One property of turbulent systems in nature that simplifies their study somewhat is that they frequently absorb and dissipate energy at vastly different spatial and temporal scales, and thus create an inertial range that emerges between the well-separated forcing and dissipation ranges in the wavenumber domain. In this intermediate range, since their behavior is close to that of a weakly-perturbed Hamiltonian system, turbulent phenomena can be approximated by Hamiltonian dynamics. Because of the typically chaotic nature of these dynamics, a statistical description is more suitable for studying turbulent phenomena than attempts at resolving individual system trajectories. One prominent facet of the statistical description is represented by the energy spectrum, which, in the inertial range, sometimes satisfies a simple scaling law. For example, in fully-developed hydrodynamic turbulence, i.e., in the high Reynolds number limit, the energy spectrum obeys Kolmogorov's  $-5/3$  power law [1]. While many advances were made since Kolmogorov's discovery of this law, numerous important questions concerning the theoretical

understanding of fluid turbulence still remain open [2, 3].

Direct numerical simulations of the incompressible Navier-Stokes (NS) equations in the turbulent regime, i.e., when the Reynolds number is extremely high, present a great computational challenge. This is because the number of degrees of freedom necessary to describe the flow increases dramatically with the increasing Reynolds number [4]. The associated computational difficulties have provided the impetus for the development and investigation of simplified reductions of the NS equations. Some of these reductions have been designed under the assumption that certain important statistical properties, such as intermittency, need not depend on the details of the system dynamics, provided they share the overall symmetry properties with these dynamics [3].

Shell models [5–8] form such a reduced class of model equations, which unlike the NS equations are not partial differential equations (PDEs), but are instead systems of ordinary differential equations (ODEs). They are usually constructed by dividing the Fourier space into shells and taking into account only a few dynamical variables per shell [5–8]. Typically, each shell is taken to be annular in shape, and the radii of neighboring shells are equidistantly distributed on the logarithmic scale. The form of the terms describing the interaction between the two sets of variables in neighboring shells is designed to reproduce some chosen features of the NS equations. Despite resulting in a drastic reduction of the original dynamics, the shell model has advanced our understand-

---

\*Electronic address: lee.wonjung@cityu.edu.hk

ing of the universal scaling laws governing the energy spectra in inertial ranges, and has revealed several hidden structures of turbulent dynamics, such as intermittency corrections to the Kolmogorov scaling [9] and to the Obukhov-Corrsin scaling for the advection of a passive scalar [10]. Importantly, it is considerably easier to perform numerical simulations of the shell model than those of the NS equations, which makes the shell model suitable for conducting detailed computational studies. Therefore, shell and related kinds of reduced models can be useful for providing insight into the behavior of fully-developed turbulence, as long as their analysis is based on a clear understanding of the resemblance and the differences between the simplified model and the original NS equations.

In contrast to hydrodynamic turbulence, the interactions among different spatial scales in many dispersive-wave systems can be analyzed in the context of the weakly-nonlinear limit. In this case, an effective time-scale separation together with a near-Gaussianity assumption allows for a systematic treatment of the statistical behavior, which results in the *weak-turbulence theory* for describing wave turbulence using kinetic equations [11]. The goal of the present paper is to apply principles resembling those involved in devising shell models to wave turbulence, and study possible energy transfer mechanisms among the waves, some of which may underlie the behavior captured by the weak turbulence theory. As it is well known that the energy transfer among the scales in a wave system occurs largely through resonant sets, typically triads or quartets [12, 13], one is compelled to choose these sets as building blocks for the reduced subsystems when constructing a shell-model analog in wave turbulence. We use a single quartet or multiple quartets to develop such a model, which we have designed to share a number of important features with the much more complicated physical or model systems exhibiting wave turbulence. For example, the four waves in a single quartet interact with one-another in the same way as those in a resonant quartet observed in typical nonlinear dispersive wave systems, such as the MMT model [14], in the long-time, small-amplitude asymptotic limit. In the case of multiple quartets, a hierarchical structure among the quartets causes energy transfer from one quartet to another, and allows for the existence of a mode without forcing and dissipation, which resembles waves in an inertial range. Furthermore, our cascade model enjoys certain theoretical advantages over the original wave-turbulence models in that because our model consists of a system of stochastic differential equations (SDEs), the probability distribution of the dynamical variables it comprises can be studied directly using the Kolmogorov forward equation (KFE), which is not case for the kinetic theory of wave turbulence. We remark that our choice of quartets for the building blocks of the cascade model is arbitrary; we could as well have chosen triads, and obtained analogous results.

We have studied the cascade model both in equilibrium

and also in non-equilibrium statistical steady state. We have determined that the equilibrium case satisfies a set of conditions that correspond to detailed balance in the thermodynamic equilibrium of turbulent wave systems. A complete statistical description of the equilibrium case of the cascade model by a Gaussian equilibrium measure derived from a corresponding Kolmogorov forward equation is possible, which also satisfies the condition of zero probability flux and the maximum-entropy principle, again in agreement with wave turbulence. Away from equilibrium, we have derived kinetic equations for the second moments of the wave-amplitudes in the cascade model, and, in examples, numerically computed their fixed points corresponding to solutions with non-zero probability flux in a statistical steady state. We have also been able to approximate the higher moments of the driven and damped modes in such a state. Finally, we have characterized the Gaussian nature of the marginal distribution of the undriven-undamped wave-mode amplitudes for the cascade model in a non-equilibrium steady state, and presented an information-theoretic argument resembling a maximum-entropy principle that explains why other initial marginal distributions should tend to this marginal distribution in forward time.

The remainder of the paper is organized as follows. In Section II, we construct a system of four-wave resonance equations, in which some wave-modes are driven and damped to generate an energy cascade. We derive equations for resonant four-wave interactions governing energy transfer among the modes of two prototypical examples of one-dimensional wave-like models, and then summarize them in a minimal general quartet model in Section II A. We then posit the cascade model in Section II B, and recast it as systems of stochastic differential equations in rectangular and polar coordinates in Section II C. In Section III we study the statistics of the cascade system in equilibrium. We derive the Kolmogorov forward equations for the cascade system and the equilibrium conditions and distributions in Section III A, and present the macroscopic view of these equations in Section III B. In particular, we derive a maximum-entropy principle for the equilibrium distributions in Section III B 1 and find a probability flux that vanishes along those distributions in Section III B 2. In Section III C, we discuss the analogies of the equilibrium cascade model with and its implications for the weak turbulence theory. In Section IV, we study the statistics of the cascade system in a non-equilibrium steady state. We derive the kinetic equations, numerically compute their fixed points in representative examples, and predict the moments of the wave-mode amplitudes in Section IV A. In Section IV B, we determine the stationary distribution of the shared-mode amplitude in a non-equilibrium steady state, and in Section IV C, we again use an argument akin to an entropy maximization principle to study how the statistics of the shared-mode amplitude relax towards this state. We summarize the results and present the conclusions in Section V.

## II. CASCADE MODEL

As mentioned in the introduction, energy transfer among different scales is largely facilitated by resonant sets, which in one spatial dimension tend to be quartets [14]. In this section, we describe how such quartets arise in the small-amplitude, long-time limit of a pair of prototypical, wave-like dynamical systems in one spatial dimension. After extracting the general form of the equation describing energy transfer through resonant quartets, we use it to construct a cascade model that describes this transfer through a sequence of such quartets. Each quartet consists of two or three modes that receive white-noise driving and linear damping, and one or two modes without the driving and damping that it shares with neighboring quartets. The energy transfer from one quartet to another proceeds via these latter modes.

### A. Equations governing the dynamics of a resonant quartet

In this section, we describe how equations describing energy transfer through excited resonant quartets of wave-modes are obtained in two typical, one-dimensional wave-like example systems. We then present a general equation that captures the salient features shared by all such equations in specific cases, and also discuss how these equations should be interpreted to relate to the energy transfer in some underlying wave-like systems.

#### 1. MMT system

For many nonlinear dispersive waves, both the linear dispersion relation of each wave and also the manner in which different waves interact with each other are rather complicated. Fortunately, under certain circumstances, both these processes can be approximately described using simple scaling laws. The MMT model [14] provides an example of the effective simplification afforded by such laws. The equation for the wave profile  $\psi(x, t)$  in this dynamical system in one spatial dimension is given by

$$i\partial_t\psi = |\partial_x|^\alpha\psi \pm |\partial_x|^{\frac{\beta}{4}} \left( \left| |\partial_x|^{\frac{\beta}{4}}\psi \right|^2 |\partial_x|^{\frac{\beta}{4}}\psi \right), \quad (1)$$

containing two parameters  $\alpha, \beta (> 0)$ . Equivalently, for the wave amplitude  $\hat{\psi}_k(t)$  in the Fourier space, Eq. (1) becomes [14–16]

$$i\partial_t\hat{\psi}_k = |k|^\alpha\hat{\psi}_k \pm \int |k_1k_2k_3k|^\frac{\beta}{4}\hat{\psi}_{k_1}\hat{\psi}_{k_2}\hat{\psi}_{k_3}^*\delta(k_1+k_2-k_3-k)dk_1dk_2dk_3. \quad (2)$$

Here,  $|\partial_x|$  denotes the pseudo-differential operator, defined by

$$(|\partial_x|^\lambda\psi)(x) := \int |k|^\lambda\hat{\psi}_ke^{ikx}dk,$$

$\hat{\psi}_k$  is the Fourier transform of  $\psi(x)$ , and  $*$  denotes the complex conjugate. While the parameter  $\alpha$  controls the linear dispersion relation  $|k|^\alpha$ ,  $\beta$  controls the strength of the nonlinearity. The  $\pm$  sign corresponds to the defocusing and focusing nonlinearities, respectively. Equations (1) [and (2)] include a number of familiar wave systems as specific cases. For example, the MMT equation becomes the nonlinear Schrödinger equation when  $\alpha = 2$ ,  $\beta = 0$ , and mimics the scalings present in water waves when  $\alpha = 1/2$ ,  $\beta = 3$ .

The (linear) energy of the wave-mode with wavenumber  $k$  is defined as  $\Omega(k)|\hat{\psi}_k|^2$ , where  $\Omega(k) = |k|^\alpha$  is the linear frequency of this mode, obtained from the linear dispersion relation, which we find in the weakly-nonlinear limit of Eq. (2). For a system with a cubic nonlinearity such as the MMT model, the dominant exchange of energy among the modes occurs via the sets of four waves whose wave numbers  $\{(k_q, k_{q'}), (k_p, k_{p'})\}$  and frequencies  $\Omega(\cdot)$  satisfy the resonance conditions

$$k_q + k_{q'} = k_p + k_{p'}, \quad (3a)$$

$$\Omega(k_q) + \Omega(k_{q'}) = \Omega(k_p) + \Omega(k_{p'}). \quad (3b)$$

Such a set of four waves is called a resonant quartet [11–13]. For the linear dispersion relation  $\Omega(k) = |k|^\alpha$  of system (2), the conditions (3) can be solved non-trivially (i.e.,  $k_q \neq k_p, k_{p'}$ ) only when  $\alpha < 1$ . If only one resonant quartet, corresponding to the wave numbers  $\{(k_1, k_2), (k_3, k_4)\}$ , is initially excited in the MMT system, the long-time behavior of the waves it comprises can be captured by seeking an asymptotic expansion of the form

$$\psi(x, t) = \sum_{j=1}^4 \epsilon A_j(\epsilon^2 t) e^{i(k_j x - |k_j|^\alpha t)} + \epsilon^3 \psi'(x, t) \quad (4)$$

for small  $\epsilon > 0$ . (Here,  $A_j$  is shorthand notation for  $A_{k_j}$ .) Substituting the trial form (4) into Eq. (1) and suppressing the secular growth leads to a system of ODEs given by [14]

$$i\partial_{\epsilon^2 t} A_q = \pm 2|k_1k_2k_3k_4|^\frac{\beta}{4} A_q^* A_p A_{p'} \pm \left( 2 \sum_{j=1}^4 |k_j|^\frac{\beta}{2} |A_j|^2 - |k_q|^\frac{\beta}{2} |A_q|^2 \right) |k_q|^\frac{\beta}{2} A_q, \quad (5)$$

where we have taken  $\{(q, q'), (p, p')\} = \{(1, 2), (3, 4)\}$ . (We will use this index-pair notation for quartets throughout the text.) The first term on the right-hand side of Eq. (5) represents the non-trivial resonant interactions of a wave with the remaining three waves

in the quartet. The second term represents the self-interaction of each wave with itself due to the trivial solution ( $k_q = k_p$  or  $k_q = k_{p'}$ ) of the conditions (3). As shown in Refs. [17, 18], we can drop this term from Eq. (5) without causing a qualitative change of the energy transfer mechanism among the resonant waves.

## 2. Hyperbolic PDE

Four-wave resonant interactions also govern the wave dynamics in the one-dimensional hyperbolic PDE

$$[\partial_t^2 + \omega^2(|\partial_x|)]u + \epsilon^2 u^3 = 0. \quad (6)$$

In the weakly nonlinear limit,  $\epsilon \rightarrow 0$ , the frequency  $\omega(\cdot)$  gives the linear dispersion relation for the wave amplitudes  $\hat{u}_k(t)$ . (Here,  $\hat{u}_k(t)$  again denotes the Fourier transform of the wave profile  $u(x, t)$ .) As in the MMT model, the substitution

$$u(x, t) = \sum_{j=1}^4 B_j(\epsilon x, \epsilon t, \epsilon^2 t) e^{i[k_j x - \omega(k_j)t]} + \epsilon u'(x, t) \quad (7)$$

into Eq. (6) yields the equations

$$i\partial_{\epsilon^2 t} B_q = \frac{3}{\omega(k_q)} B_q^* B_p B_{p'} + \frac{3}{2\omega(k_q)} \left( 2 \sum_{j=1}^4 |B_j|^2 - |B_q|^2 \right) B_q. \quad (8)$$

A detailed derivation of Eq. (8) using multiple time-scale analysis of Eqs. (6) via the ansatz (7) can be found in Appendix A. As in the case of the MMT model, the second term on the right-hand side of Eq. (8) arises from self-interactions of the wave  $B_q$ , and can be removed with no qualitative loss of information.

## 3. General structure of a four-wave resonant quartet

As the result of the above considerations, an equation of the following general form,

$$i\partial_t a_q = T_q a_q^* a_p a_{p'}, \quad (9)$$

obtained by ignoring the self-interaction terms in either Eq. (5) or Eq. (8), captures the asymptotic evolution of the respective wave profiles in a resonant quartet over the time-scale of order  $\epsilon^{-2}$ . Here,  $a_q$  (i.e., shorthand notation for  $a_{k_q}$ ) is one of the four waves with subscripts  $\{(k_q, k_{q'}), (k_p, k_{p'})\}$  satisfying Eq. (3) with the appropriate frequency  $\Omega(\cdot)$  depending on the system under study. We note that the interaction tensor  $T_q = \pm 2|k_1 k_2 k_3 k_4|^{\beta/4}$  in the four-wave resonance equation (5) of the MMT system is independent of the mode  $q$  and also of the linear dispersion relation  $|k|^\alpha$ . On the other

hand, the coefficients  $T_q = 3/\omega(k_q)$  in Eq. (8) vary with the choice of the index  $q$ , and are determined by the linear dispersion relation  $\omega(\cdot)$ . This difference arises due to the disparate effective time-scales, i.e.,  $A_j$  in Eq. (4) is a function of  $\epsilon^2 t$ , while  $B_j$  in Eq. (7) is a function of  $\epsilon t$  and  $\epsilon^2 t$ . Therefore, it is important to study not only a specific case but rather the general form of the interaction tensor  $T_q$  in Eq. (9).

As in the two specific examples given above, in general, the dynamics of the system (9) mediates the transfer of the energy  $\Omega(k_q) |a_{k_q}|^2$  among the four excited resonant modes in the underlying wave system with the (here unspecified) dispersion relation  $\Omega(k)$ . In the single and multiple quartet systems studied in the remainder of this paper, the term *energy transfer* will be used in this same sense.

We should remark that there exist numerous examples, in one and more dimensions [11, 19], in which energy is transferred through resonant triads of modes instead of quartets. In the above two examples, triads are absent. In particular, in the MMT model (1), they are absent due to its linear dispersion relation not allowing for the existence of three-wave resonances analogous to the four-wave resonances described by Eqs. (3) [14]. In the hyperbolic PDE, triads are absent because the cubic nonlinearity implies that all their corresponding coupling coefficients (the analogs of  $T_q$  in Eq. (9) that would multiply products of two rather than three wave profiles) vanish. We do not consider examples of energy transfer through resonant triads, or triads themselves, here, but again emphasize that all our results below could equally well be developed for resonant triads.

## B. Cascade of resonant quartets with driving and damping

A single mode in wave turbulence exchanges energy with other modes in the system, including possibly some that are not resolved by the assumed mode expansion, in a chaotic fashion. Frequently, the influence of unresolved modes or subgrid-scale effects on a given mode can be approximated by white-noise driving and linear damping [20]. In this section, we present a set of model equations for a quartet of such modes, and then generalize it to two and more quartets that are coupled through a (cascade of) shared mode(s).

### 1. Single quartet

In the case of a single resonant quartet, using Eq. (9) and two sets of parameters,  $\sigma_q$  and  $\nu_q (> 0)$ , we find that the model equation for (any) one of its driven-damped wave-modes, as mentioned above, can be written in the form

$$i\partial_t a_q = T_q a_q^* a_p a_{p'} - i\nu_q a_q + \sigma_q \dot{W}_q, \quad (10)$$

where  $\dot{W}_q$  denotes complex-valued Gaussian white noise, whose realizations are independent among different values of the wavenumber  $q$ . This scenario is illustrated in the left panel of Fig. 1, where the crossed bars denote interactions among the four wave-modes governed by Eq. (9), and the two-sided vertical arrows for each wave denote the corresponding forcing and dissipation described in Eq. (10).

We here mention that, when  $T_q = 0$ , i.e., in the absence of any resonant interactions among the waves, Eq. (10) reduces to a description of the Ornstein-Uhlenbeck process [21, 22]. We also mention that, if the parameters  $T_q$  are all equal and if two modes  $(k_q, k_{q'})$  are driven by white noise of equal strength ( $\sigma_q = \sigma_{q'} \neq 0$ ) without damping ( $\nu_q = \nu_{q'} = 0$ ) and two modes  $(k_p, k_{p'})$  are equally damped ( $\nu_p = \nu_{p'} \neq 0$ ) without driving ( $\sigma_p = \sigma_{p'} = 0$ ), then this single quartet reduces to the resonant duet model ( $a_q$  and  $a_p$ ), introduced in [17, 18]. There, for a fixed value of the driving parameter  $\sigma_q$ , the statistical behavior of the duet exhibits a transition from near-Gaussian to highly intermittent behavior as the dissipation controlled by the damping parameter  $\nu_p$  increases from weak to strong.

Below, we will proceed by building models describing multiple quartets, coupled through shared wave-modes that have no external driving-damping.

## 2. Double quartets

We next consider a pair of resonant quartets whose wave numbers are given by  $\{(k_1, k_2), (k_3, k_{4'})\}$  and  $\{(k_{4'}, k_5), (k_6, k_7)\}$ , which share a wave,  $a_{4'}$ . (We use the notation  $a_{4'}$  in order to distinguish this shared mode from the mode  $a_4$  in a single quartet.) We construct a dynamical system consisting of these two quartets, in which the waves are forced by white noise and linearly dissipated, except for the shared mode which mediates the interaction between the two quartets, as illustrated in the right panel of Fig. 1. While the equations for the non-shared waves are the same as Eq. (10), the equation for the shared wave is given by

$$i\partial_t a_{4'} = T_{4'} a_3^* a_1 a_2 + T_{4'}' a_5^* a_6 a_7, \quad (11)$$

where  $T_{4'}$  and  $T_{4'}'$  denote the interaction tensors of the mode  $a_{4'}$  in the resonant quartets  $\{(k_1, k_2), (k_3, k_{4'})\}$  and  $\{(k_{4'}, k_5), (k_6, k_7)\}$ , respectively. This shared mode behaves very much like the waves in an inertial range of a general nonlinear dispersive wave system in that the statistics of the mode  $a_{4'}$  are determined by the nature of the energy transfer from other modes through this mode. Therefore, the statistical behavior of this type of waves is of particular interest to our investigation.

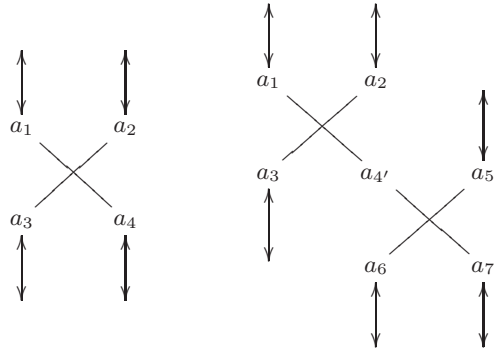

FIG. 1: Left panel: single quartet. Right panel: double quartets shared by one mode.

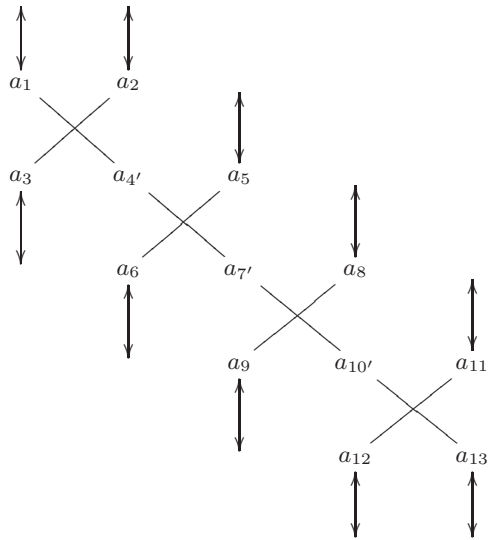

FIG. 2: An example of hierarchical resonant quartets.

## 3. Hierarchical cascade of quartets

Using more than two quartets, we can construct a hierarchical set of four-wave resonant quartets, with each pair of quartets in the hierarchy sharing one mode, and in which all the waves except the shared ones are driven-damped, as shown in Fig. 2. We refer to the model constructed in this way as the *cascade model*.

We have designed our cascade model so as to provide insight into possible energy transfer mechanisms in wave turbulence, and have utilized in its construction certain parallels with principles used in designing shell models in fluid turbulence. Thus, although the equations of motion in these two model types appear very different, they do share one common design feature: both comprise a hierarchy of modes in an inertial range, with the

energy transfer through these modes occurring via the interactions between the nearest neighbors in the hierarchy. However, one of their key differences is that, in contrast to shell models in fluid turbulence, in which the modes are ordered according to the size of the associated wave numbers and thus strictly local interactions in the Fourier space are postulated, there is no such ordering among the elements of the hierarchy in our cascade model of wave turbulence. Therefore, non-local interactions within a resonant quartet can be described by our cascade model of wave turbulence. For example,  $\{(k_1, k_2), (k_3, k_4)\} = \{(400, 25), (441, -16)\}$  gives one solution of the conditions (3) for the MMT system with  $\alpha = 1/2$ .

We should here re-iterate that we only consider white-noise forcing for the cascade model in this paper. This is because our intent is to mimic energy transfer among modes in the inertial ranges of weakly-turbulent systems, in which the influence of the unresolved (including directly-forced) modes should be well modeled by white noise [20].

### C. Coordinate representations of the cascade model

In this section, we rewrite the cascade models we posited above in terms of real coordinates, which will enable us to perform further analysis of these models using stochastic and statistical-mechanical methods.

#### 1. Rectangular coordinates

When we represent the complex-valued wave amplitude as  $a_q = x_q + iy_q$  using its real-valued components  $x_q$  and  $y_q$ , the SDEs in Eq. (10) can be written in terms of these components as stochastic differential equations

$$\begin{aligned} dx_q &= \mu_{x_q} dt + \frac{\sigma_q}{\sqrt{2}} dB_{x_q}, \\ dy_q &= \mu_{y_q} dt + \frac{\sigma_q}{\sqrt{2}} dB_{y_q}, \end{aligned} \quad (12)$$

in which the coefficients  $\mu_{x_q}$  and  $\mu_{y_q}$  are given by the expressions

$$\begin{aligned} \mu_{x_q} &\equiv -\nu_q x_q + T_q \text{Im}(a_{q'}^* a_p a_{p'}), \\ \mu_{y_q} &\equiv -\nu_q y_q - T_q \text{Re}(a_{q'}^* a_p a_{p'}). \end{aligned} \quad (13)$$

Here, and throughout the text, we let  $B_X$  denote the Brownian motion driving the dynamical variable  $X$ , and assume that  $B_X$  and  $B_Y$  are independent when  $X \neq Y$ .

Likewise, for the system of double quartets, Eq. (11) for the shared mode  $a_{4'} = x_{4'} + iy_{4'}$  is rewritten as the pair of equations

$$\begin{aligned} dx_{4'} &= \mu_{x_{4'}} dt, \\ dy_{4'} &= \mu_{y_{4'}} dt, \end{aligned} \quad (14)$$

in which the coefficients  $\mu_{x_{4'}}$  and  $\mu_{y_{4'}}$  are given by the expressions

$$\begin{aligned} \mu_{x_{4'}} &\equiv T_{4'} \text{Im}(a_3^* a_1 a_2) + T_{4'}' \text{Im}(a_5^* a_6 a_7), \\ \mu_{y_{4'}} &\equiv -T_{4'} \text{Re}(a_3^* a_1 a_2) - T_{4'}' \text{Re}(a_5^* a_6 a_7). \end{aligned} \quad (15)$$

We can also readily obtain the corresponding SDEs for dynamical systems consisting of more than two quartets such as the one shown in Fig. 2.

#### 2. Polar coordinates

The eight variables,  $\{x_j, y_j \mid j = 1, \dots, 4\}$ , used to describe the system consisting of a single quartet in Eq. (12), can be reduced in number by transforming Eq. (12) to the polar-coordinate representation,  $a_j = \rho_j e^{i\theta_j}$ . In this representation, only five variables,  $\{\rho_j, \phi \mid j = 1, \dots, 4\}$ , where  $\phi \equiv \theta_4 + \theta_3 - \theta_2 - \theta_1$  is the resonant linear combination of the phases  $\theta_j$ , are necessary to determine the dynamics of the corresponding equations in formula (10) due to their phase symmetry. The corresponding SDEs for the radii and the resonant angle,  $\{\rho_j, \phi\}$ , are given by

$$d\rho_q = \mu_{\rho_q} dt + \frac{\sigma_q}{\sqrt{2}} dB_{\rho_q}, \quad (16a)$$

$$d\phi = \mu_{\phi} dt + \sqrt{\sum_{j=1}^4 \left( \frac{\sigma_j^2}{2\rho_j^2} \right)} dB_{\phi}, \quad (16b)$$

where the coefficients  $\mu_{\rho_q}$  and  $\mu_{\phi}$  are expressed as

$$\begin{aligned} \mu_{\rho_q} &\equiv \frac{\sigma_q^2}{4\rho_q} - \nu_q \rho_q + T_q \rho_{q'} \rho_p \rho_{p'} \sin(\theta_{p'} + \theta_p - \theta_{q'} - \theta_q) \\ &= \frac{\sigma_q^2}{4\rho_q} - \nu_q \rho_q \pm T_q \rho_{q'} \rho_p \rho_{p'} \sin(\phi), \\ \mu_{\phi} &\equiv \left( \frac{T_1}{\rho_1^2} + \frac{T_2}{\rho_2^2} - \frac{T_3}{\rho_3^2} - \frac{T_4}{\rho_4^2} \right) \rho_1 \rho_2 \rho_3 \rho_4 \cos(\phi). \end{aligned} \quad (17)$$

In the definition of the variable  $\mu_{\rho_q}$ ,  $+$  is used for  $q = 1, 2$  and  $-$  is used for  $q = 3, 4$ . The non-resonant angles are absent from the right-hand sides of Eqs. (16), and can be solved for subsequently via quadratures.

Similarly, for the system of double quartets, the fourteen variables  $\{x_j, y_j \mid j = 1, \dots, 7\}$  (we ignore the prime in  $4'$  for notational brevity) can be reduced to the nine variables  $\{\rho_j, \phi', \varphi \mid j = 1, \dots, 7\}$  where  $\phi' \equiv \theta_{4'} + \theta_3 - \theta_2 - \theta_1$  and  $\varphi \equiv \theta_7 + \theta_6 - \theta_5 - \theta_{4'}$  are the two resonant angles. In this case, the SDEs are given by Eq. (16a) for  $\rho_j$  with  $j \neq 4'$ , and

$$\begin{aligned} d\rho_{4'} &= \mu_{\rho_{4'}} dt, \\ d\phi' &= \mu_{\phi'} dt + \sqrt{\sum_{j=1}^3 \left( \frac{\sigma_j^2}{2\rho_j^2} \right)} dB_{\phi'}, \\ d\varphi &= \mu_{\varphi} dt + \sqrt{\sum_{j=5}^7 \left( \frac{\sigma_j^2}{2\rho_j^2} \right)} dB_{\varphi}, \end{aligned} \quad (18)$$

where

$$\begin{aligned}
\mu_{\rho_{4'}} &\equiv -T_{4'}\rho_1\rho_2\rho_3\sin(\phi') + T_{4'}'\rho_5\rho_6\rho_7\sin(\varphi), \\
\mu_{\phi'} &\equiv \left(\frac{T_1}{\rho_1^2} + \frac{T_2}{\rho_2^2} - \frac{T_3}{\rho_3^2} - \frac{T_{4'}}{\rho_{4'}^2}\right)\rho_1\rho_2\rho_3\rho_{4'}\cos(\phi') \\
&\quad - \left(\frac{T_{4'}}{\rho_{4'}^2}\right)\rho_{4'}\rho_5\rho_6\rho_7\cos(\varphi), \\
\mu_{\varphi} &\equiv \left(\frac{T_{4'}'}{\rho_{4'}^2} + \frac{T_5}{\rho_5^2} - \frac{T_6}{\rho_6^2} - \frac{T_7}{\rho_7^2}\right)\rho_{4'}\rho_5\rho_6\rho_7\cos(\varphi) \\
&\quad + \left(\frac{T_{4'}}{\rho_{4'}^2}\right)\rho_1\rho_2\rho_3\rho_{4'}\cos(\phi').
\end{aligned} \tag{19}$$

Writing down the corresponding SDEs for a hierarchical system of more than two quartets is a straightforward generalization of the procedure described above.

### III. CASCADE MODEL IN STATISTICAL EQUILIBRIUM

In this section, we study a class of cascade models that reaches a statistical equilibrium. We find the proper balance of the driving-damping parameters that allow for the existence of this equilibrium by determining when the Kolmogorov forward equation (KFE) corresponding to the cascade-model SDEs, presented in the previous section, possesses a Gaussian stationary solution, which we show to be the model's equilibrium measure using a maximum entropy argument. The model relaxes towards this measure regardless of its initial condition, and so the statistical equilibrium is unique. We also derive an appropriate probability flux that vanishes on the equilibrium measure. We find that the parameter-balance condition, which ensures the existence of the statistical equilibrium in the cascade model, corresponds to conditions in the wave turbulence theory that lead to the thermodynamic equilibrium. The vanishing of the probability flux in our model corresponds to the vanishing of the net energy (and also wave-action) flux through the system in the thermodynamic equilibrium of wave-turbulence models.

#### A. Stationary solution of the Kolmogorov forward equation

In this section, we derive KFEs that correspond to the stochastic models of resonant quartets discussed in the previous section, and find the conditions for the existence and the form of their Gaussian equilibrium solutions.

##### 1. KFE and equilibrium in rectangular coordinates

For the cascade model consisting of  $N$  waves, we denote the probability distribution of the variables  $a_j = x_j + iy_j$  by  $P = P(t, \{x_j, y_j\})$ ,  $j = 1, \dots, N$ . In the case

of multiple quartets, we ignore the prime in the subscript of the shared wave. (For example,  $a_4$  in a double quartet is understood as  $a_{4'}$  if  $N > 4$ .) We let  $\mathcal{G}$  be the infinitesimal generator of the SDEs for the general cascade model, which is given by

$$\mathcal{G} \equiv \sum_{j=1}^N \left[ \mu_{x_j} \partial_{x_j} + \mu_{y_j} \partial_{y_j} + \frac{\sigma_j^2}{4} (\partial_{x_j}^2 + \partial_{y_j}^2) \right], \tag{20}$$

where  $\mu_{x_j}$  and  $\mu_{y_j}$  are defined in as Eqs. (13), (15). Then, the evolution of the distribution  $P$  is governed by the KFE

$$\begin{aligned}
\partial_t P = \mathcal{G}^\dagger P = & - \sum_{j=1}^N \left[ \partial_{x_j} \left( \mu_{x_j} P - \frac{\sigma_j^2}{4} \partial_{x_j} P \right) \right. \\
& \left. + \partial_{y_j} \left( \mu_{y_j} P - \frac{\sigma_j^2}{4} \partial_{y_j} P \right) \right],
\end{aligned} \tag{21}$$

where  $\mathcal{G}^\dagger$  denotes the adjoint of  $\mathcal{G}$  [22]. The boundary conditions we consider for Eq. (21) are that  $P$ ,  $\partial_{x_j} P$  and  $\partial_{y_j} P$  vanish as  $|x_j|, |y_j| \rightarrow \infty$ .

For the system consisting of a single quartet, we denote the distribution  $P$  by  $P_s$  and the infinitesimal generator  $\mathcal{G}$  by  $\mathcal{G}_s$ . For this system, substituting the Gaussian distribution

$$P_s^0(x_j, y_j) \equiv \prod_{j=1}^4 \frac{\gamma_j}{\pi} e^{-\gamma_j(x_j^2 + y_j^2)} \tag{22}$$

into Eq. (21) with  $N = 4$  yields

$$\begin{aligned}
\mathcal{G}_s^\dagger P_s^0 = & \sum_{j=1}^4 \left( \nu_j - \frac{\sigma_j^2}{2} \gamma_j \right) (\partial_{x_j} (x_j P_s^0) + \partial_{y_j} (y_j P_s^0)) \\
& + 2(T_1\gamma_1 + T_2\gamma_2 - T_3\gamma_3 - T_4\gamma_4) \text{Im}(a_1^* a_2^* a_3 a_4).
\end{aligned} \tag{23}$$

We find that the Gaussian  $P_s^0$  with the parameters  $\gamma_j$  satisfying the equations

$$\gamma_j = \frac{2\nu_j}{\sigma_j^2} \tag{24}$$

and the condition

$$T_1\gamma_1 + T_2\gamma_2 - T_3\gamma_3 - T_4\gamma_4 = 0 \tag{25}$$

becomes a stationary solution of the KFE in Eq. (21).

Note that Eq. (25) is a special condition on the driving-damping parameters of the single-quartet cascade model, which thus singles out a particular class of such models. There are single-quartet models that do not satisfy this condition, and so do not possess stationary solutions of the form in Eq. (22). We will study these latter kinds of cascade models later in Section IV.

As mentioned above, without interactions among the waves, i.e., when  $T_j = 0$ , the SDE (10) of each wave profile becomes the Ornstein-Uhlenbeck process. In this



case, the function in Eq. (22) with the parameters  $\gamma_j$  satisfying Eq. (24) is the unique time-independent measure [22]. Eq. (23) reveals that there is no difference in the statistics of the driven-damped waves in Eq. (10) between the two cases with and without the nonlinear interactions, once the condition (25) holds for the system in question. When the wave interactions  $T_j$  do not vanish, the role they and Eq. (25) play in this scenario is to select the balance among the relations (24) between the driving and damping of the individual wave-modes for which these same statistics persist in the coupled model.

For the system consisting of double quartets, we denote the probability distribution of the wave-amplitude components,  $P$ , by  $P_d$  and the infinitesimal generator of the corresponding SDEs,  $\mathcal{G}$ , by  $\mathcal{G}_d$ . We again substitute the Gaussian distribution

$$P_d^0(x_j, y_j) \equiv \prod_{j=1}^7 \frac{\gamma_j}{\pi} e^{-\gamma_j(x_j^2 + y_j^2)} \quad (26)$$

into Eq. (21) with  $N = 7$ , to obtain the value of the adjoint,  $\mathcal{G}_d^\dagger$ , evaluated on it, which is

$$\begin{aligned} \mathcal{G}_d^\dagger P_d^0 &= \sum_{\substack{j=1 \\ j \neq 4}}^7 \left( \nu_j - \frac{\sigma_j^2}{2} \gamma_j \right) [\partial_{x_j} (x_j P_d^0) + \partial_{y_j} (y_j P_d^0)] \\ &+ 2(T_1 \gamma_1 + T_2 \gamma_2 - T_3 \gamma_3 - T_{4'} \gamma_{4'}) \text{Im}(a_1^* a_2^* a_3 a_{4'}) \\ &+ 2(T_{4'}' \gamma_{4'} + T_5 \gamma_5 - T_6 \gamma_6 - T_7 \gamma_7) \text{Im}(a_{4'}^* a_5^* a_6 a_7). \end{aligned} \quad (27)$$

The expression in Eq. (27) vanishes when the parameters  $\gamma_j$ ,  $j \neq 4$ , are given by Eq. (24), and there exists a non-zero value of the parameter  $\gamma_{4'}$  that satisfies the equations

$$T_1 \gamma_1 + T_2 \gamma_2 - T_3 \gamma_3 - T_{4'} \gamma_{4'} = 0, \quad (28a)$$

$$T_{4'}' \gamma_{4'} + T_5 \gamma_5 - T_6 \gamma_6 - T_7 \gamma_7 = 0. \quad (28b)$$

This implies that the Gaussian function  $P_d^0$  in Eq. (26), with the parameters  $\gamma_j$  defined by the equations (24) when  $j \neq 4$  (i.e., for the driven-damped modes but not the shared mode), in any special system of double quartets in which all  $\gamma_j$  satisfy the condition (28), becomes a stationary solution of the KFE (21) with  $N = 7$ . Thus, again, the condition (28) singles out a special class of system of double quartets that allow for the existence of a Gaussian steady state.

Interestingly, the marginal distribution of the shared mode,

$$P_d^0(x_{4'}, y_{4'}) \equiv \int P_d^0(x_j, y_j) \prod_{\substack{j=1 \\ j \neq 4}}^7 dx_j dy_j = \frac{\gamma_{4'}}{\pi} e^{-\gamma_{4'}(x_{4'}^2 + y_{4'}^2)}, \quad (29)$$

is Gaussian, just as for the driven-damped waves. However, the corresponding randomness it represents is induced by the four-wave resonant interactions and not by the forcing and dissipation. [Cf. Eq. (11).]

For a system of more than two quartets, it is not too difficult to verify that the Gaussian distribution

$$P^0(x_j, y_j) \equiv \prod_{j=1}^N \frac{\gamma_j}{\pi} e^{-\gamma_j(x_j^2 + y_j^2)}, \quad (30)$$

whose parameters  $\gamma_j$  for the driven-damped modes are defined by Eq. (24), in the class of systems in which all  $\gamma_j$  satisfy conditions analogous to Eq. (25) or Eq. (28), is a stationary solution of the corresponding KFE (21). As we will demonstrate below in Section III C, Eqs. (25) and (28) are the analogs of the detailed-balance conditions that define the Rayleigh-Jeans spectra corresponding to the thermodynamic equilibrium in weak turbulence theory.

## 2. KFE and equilibrium in polar coordinates

An equivalent result can be obtained using the polar representation of the SDEs describing our cascade model, for which the probability distribution and the infinitesimal generator will be denoted by  $\tilde{P}$  and  $\tilde{\mathcal{G}}$ , respectively. In this representation, we obtain the KFE

$$\partial_t \tilde{P} = \tilde{\mathcal{G}}^\dagger \tilde{P}, \quad (31)$$

which is equivalent to Eq. (21).

For the system consisting of a single quartet, we again denote the probability distribution  $\tilde{P}$  by  $\tilde{P}_s$  and the infinitesimal generator  $\tilde{\mathcal{G}}$  by  $\tilde{\mathcal{G}}_s$ . For the distribution  $\tilde{P}_s$ , we find the relation

$$\tilde{P}_s(t, \{\rho_j, \phi\}) = P_s(t, \{x_j, y_j\}) \times (2\pi)^3 \prod_{j=1}^4 \rho_j,$$

where  $\prod_{j=1}^4 \rho_j$  is the Jacobian of the transformation to polar coordinates, and the normalization constant  $(2\pi)^3$  arises from the reduction of the four phases  $\{\theta_j \mid j = 1, \dots, 4\}$  to the single resonant phase  $\phi \in [0, 2\pi)$ . We use Eq. (16) to obtain the form of the infinitesimal generator,

$$\tilde{\mathcal{G}}_s = \sum_{j=1}^4 \left[ \mu_{\rho_j} \partial_{\rho_j} + \frac{\sigma_j^2}{4} \partial_{\rho_j}^2 \right] + \left[ \mu_\phi \partial_\phi + \left( \sum_{j'=1}^4 \frac{\sigma_{j'}^2}{4\rho_{j'}^2} \right) \partial_\phi^2 \right], \quad (32)$$

and the KFE

$$\begin{aligned} \partial_t \tilde{P}_s &= \tilde{\mathcal{G}}_s^\dagger \tilde{P}_s = - \sum_{j=1}^4 \left[ \partial_{\rho_j} \left( \mu_{\rho_j} \tilde{P}_s - \frac{\sigma_j^2}{4} \partial_{\rho_j} \tilde{P}_s \right) \right] \\ &- \partial_\phi \left( \mu_\phi \tilde{P}_s - \left( \sum_{j'=1}^4 \frac{\sigma_{j'}^2}{4\rho_{j'}^2} \right) \partial_\phi \tilde{P}_s \right), \end{aligned} \quad (33)$$

where the coefficients  $\mu_{\rho_j}$  and  $\mu_\phi$  are defined in Eq. (17). The boundary conditions we consider for Eq. (33) are

that  $\tilde{P}_s$ ,  $\partial_{\rho_j}\tilde{P}_s$  and  $\partial_\phi\tilde{P}_s$  vanish as  $\rho_j \rightarrow \infty$ , and are periodic with respect to the phase  $\phi$ . We see that the Gaussian distribution

$$\tilde{P}_s^0(\rho_j, \phi) \equiv \frac{1}{2\pi} \prod_{j=1}^4 \left( 2\gamma_j e^{-\gamma_j \rho_j^2} \rho_j \right), \quad (34)$$

which does not depend on the variable  $\phi$  and in which the parameters  $\gamma_j$  are defined in Eq. (24), becomes a stationary solution of Eq. (33), provided that the system is chosen so that the parameters  $\gamma_j$  satisfy the condition (25).

For the system consisting of a pair of quartets, we denote the probability distribution  $\tilde{P}$  by  $\tilde{P}_d$  and the infinitesimal generator  $\tilde{\mathcal{G}}$  by  $\tilde{\mathcal{G}}_d$ . For the function  $\tilde{P}_d$ , we find the relation

$$\tilde{P}_d(t, \{\rho_j, \phi', \varphi\}) = P_d(t, \{x_j, y_j\}) \times (2\pi)^5 \prod_{j=1}^7 \rho_j.$$

We use Eq. (18) to obtain the form of the infinitesimal generator

$$\begin{aligned} \tilde{\mathcal{G}}_d = & \sum_{\substack{j=1 \\ j \neq 4}}^7 \left[ \mu_{\rho_j} \partial_{\rho_j} + \frac{\sigma_j^2}{4} \partial_{\rho_j}^2 \right] + \mu_{\rho_{4'}} \partial_{\rho_{4'}} \\ & + \left[ \mu_{\phi'} \partial_{\phi'} + \left( \sum_{j'=1}^3 \frac{\sigma_{j'}^2}{4\rho_{j'}^2} \right) \partial_{\phi'}^2 \right] \\ & + \left[ \mu_\varphi \partial_\varphi + \left( \sum_{j''=5}^7 \frac{\sigma_{j''}^2}{4\rho_{j''}^2} \right) \partial_\varphi^2 \right], \end{aligned} \quad (35)$$

and the KFE

$$\begin{aligned} \partial_t \tilde{P}_d = & \tilde{\mathcal{G}}_d^\dagger \tilde{P}_d \\ = & - \sum_{\substack{j=1 \\ j \neq 4}}^7 \left[ \partial_{\rho_j} \left( \mu_{\rho_j} \tilde{P}_d - \frac{\sigma_j^2}{4} \partial_{\rho_j} \tilde{P}_d \right) \right] - \partial_{\rho_{4'}} \left( \mu_{\rho_{4'}} \tilde{P}_d \right) \\ & - \partial_{\phi'} \left( \mu_{\phi'} \tilde{P}_d - \left( \sum_{j'=1}^3 \frac{\sigma_{j'}^2}{4\rho_{j'}^2} \right) \partial_{\phi'} \tilde{P}_d \right) \\ & - \partial_\varphi \left( \mu_\varphi \tilde{P}_d - \left( \sum_{j''=5}^7 \frac{\sigma_{j''}^2}{4\rho_{j''}^2} \right) \partial_\varphi \tilde{P}_d \right), \end{aligned} \quad (36)$$

where the coefficients  $\mu_{\rho_j}$ ,  $j \neq 4$ , are defined in Eq. (17), and  $\mu_{\rho_{4'}}$ ,  $\mu_{\phi'}$  and  $\mu_\varphi$  are defined in Eq. (19). We consider boundary conditions similar to the case of a single quartet, and find that the Gaussian distribution

$$\tilde{P}_d^0(\rho_j, \phi', \varphi) \equiv \left( \frac{1}{2\pi} \right)^2 \prod_{j=1}^7 \left( 2\gamma_j e^{-\gamma_j \rho_j^2} \rho_j \right), \quad (37)$$

which does not depend on the variables  $\phi'$  and  $\varphi$  and whose parameters  $\gamma_j$  with  $j \neq 4$  are defined by Eq. (24),

becomes a stationary solution of Eq. (36), provided the system is such that all  $\gamma_j$  satisfy conditions (28). In this case, we denote the marginal distribution of the wave amplitude  $\rho_{4'}$  by

$$\tilde{P}_d^0(\rho_{4'}) \equiv \int \tilde{P}_d^0(\rho_j, \phi', \varphi) \prod_{\substack{j=1 \\ j \neq 4}}^7 d\rho_j d\phi' d\varphi = 2\gamma_{4'} e^{-\gamma_{4'} \rho_{4'}^2} \rho_{4'}, \quad (38)$$

which agrees with Eq. (29) up to the Jacobian and normalization constant.

For a system of more than two quartets, it is clear how to obtain the KFE (31) and its Gaussian stationary solution  $\tilde{P}^0$ , provided its driving-damping parameters allow for conditions analogous to Eq. (25) or Eq. (28) to be satisfied.

We have thus seen that only a special sub-class of cascade models admits Gaussian-type stationary probability distributions, namely those whose driving-damping parameters allow for conditions of the type given in Eq. (25) or Eq. (28) to be satisfied. In the remainder of the current section, we will take a closer look at this sub-class.

## B. Macroscopic view of the cascade model

In the previous section, we identified a class of cascade models that admit a stationary Gaussian probability distribution  $P^0$  (or  $\tilde{P}^0$ ) as a solution to the corresponding KFE. We now expand our finding by showing that, in this class, the Gaussian distribution we have identified is in fact the equilibrium measure of the corresponding cascade model. Moreover, we find an appropriate probability flux which vanishes along this measure.

### 1. Maximal entropy principle for equilibrium distribution

Motivated by the knowledge that irreversible evolution towards the thermodynamic equilibrium is characterized by a simultaneous increase of entropy [23], we here establish an entropy maximization argument whose result shows the distribution  $P^0$  to be at the global maximum value of the appropriate entropy function. This argument simultaneously shows that all other solutions of the KFE for the cascade model relax towards  $P^0$  at large times.

For our cascade model, we consider the relative entropy of an arbitrary distribution  $P$  with respect to the Gaussian distribution  $P^0$ ,

$$\begin{aligned} \mathcal{S}_{\text{EQ}}(P, P^0) & \equiv - \left\langle \log \left( \frac{P}{P^0} \right) \right\rangle \\ & = - \int P \log \left( \frac{P}{P^0} \right) dA, \end{aligned} \quad (39)$$

where  $dA = \prod_{j=1}^N dx_j dy_j = \prod_{j=1}^N \rho_j d\rho_j d\theta_j$ , and show that it increases along the trajectories of the SDEs describing the model and achieves its maximum when  $P =$

$P^0$ . Here, we denote by  $\langle \cdot \rangle$  the statistical average over the distribution  $P$ . We remark that, instead of the distributions  $P$  and  $P^0$  in the rectangular coordinates, we can use for the definition of the relative entropy their counterparts in the polar coordinates,  $\tilde{P}$  and  $\tilde{P}^0$ . Namely, since Eq. (39) is invariant under coordinate transformations, we see that  $\mathcal{S}_{\text{EQ}}(\tilde{P}, \tilde{P}^0)$  is equivalent to  $\mathcal{S}_{\text{EQ}}(P, P^0)$  up to a constant factor.

For a single quartet, the calculation in Appendix B shows that the time derivative of Eq. (39) under the dynamics of Eqs. (33) is given by the expression

$$\begin{aligned} \frac{d}{dt} \mathcal{S}_{\text{EQ}}(P_s, P_s^0) &= \sum_{j=1}^4 \int \frac{4\rho_j^2}{\sigma_j^2 P_s} \left[ \left( \nu_j P_s + \frac{\sigma_j^2}{4\rho_j} \partial_{\rho_j} P_s \right)^2 \right. \\ &\quad \left. + \left( \frac{\sigma_j^2}{4\rho_j^2} \partial_{\theta_j} P_s \right)^2 \right] dA \\ &\quad - 2(T_1\gamma_1 + T_2\gamma_2 - T_3\gamma_3 - T_4\gamma_4) \\ &\quad \times \int \rho_1 \rho_2 \rho_3 \rho_4 \sin(\phi) P_s dA, \end{aligned} \quad (40)$$

in which the parameters  $\gamma_j$  are defined in terms of the driving-damping parameters  $\sigma_j$  and  $\nu_j$  through Eq. (24). In the class of systems in which condition (25) holds, the right-hand side of Eq. (40) is positive semi-definite, and vanishes precisely when  $P_s = P_s^0$ , given in Eq. (22), so that the relative entropy is maximized precisely when  $P_s = P_s^0$ . Therefore, in this class of systems, any initial distribution of modes relaxes irreversibly to the Gaussian distribution  $P_s^0$ .

For a pair of quartets, a similar calculation using Eqs. (36) yields the equation

$$\begin{aligned} \frac{d}{dt} \mathcal{S}_{\text{EQ}}(P_d, P_d^0) &= \sum_{\substack{j=1 \\ j \neq 4}}^7 \int \frac{4\rho_j^2}{\sigma_j^2 P_d} \left[ \left( \nu_j P_d + \frac{\sigma_j^2}{4\rho_j} \partial_{\rho_j} P_d \right)^2 \right. \\ &\quad \left. + \left( \frac{\sigma_j^2}{4\rho_j^2} \partial_{\theta_j} P_d \right)^2 \right] dA \\ &\quad - 2(T_1\gamma_1 + T_2\gamma_2 - T_3\gamma_3 - T_{4'}\gamma_{4'}) \\ &\quad \times \int \rho_1 \rho_2 \rho_3 \rho_{4'} \sin(\phi') P_d dA \\ &\quad - 2(T_{4'}\gamma_{4'} + T_5\gamma_5 - T_6\gamma_6 - T_7\gamma_7) \\ &\quad \times \int \rho_{4'} \rho_5 \rho_6 \rho_7 \sin(\varphi) P_d dA, \end{aligned} \quad (41)$$

in which the parameters  $\gamma_j$ ,  $j \neq 4$ , are again defined through Eq. (24). In the class of systems in which conditions (28) hold, the right-hand side of Eq. (41) is positive semi-definite and vanishes exactly when  $P_d = P_d^0$ , given in Eq. (26). Therefore, any initial mode distribution again relaxes irreversibly to the Gaussian distribution  $P_d^0$ .

One can readily obtain the time derivative of the relative entropy in Eq. (39) for a system of more than two

quartets. This derivative is positive semi-definite and vanishes precisely when  $P = P^0$ , the Gaussian stationary distribution given in Eq. (30), with the parameters  $\gamma_j$  of the driven-damped modes defined via Eq. (24), in the class of cascade systems in which all the parameters  $\gamma_j$  satisfy equations analogous to Eqs. (25) and (28). Therefore, in such systems, the relative entropy  $\mathcal{S}_{\text{EQ}}(P, P^0)$  indeed increases as time evolves, unless the probability distribution of the cascade model is the distribution  $P^0$ , to which all other distributions relax irreversibly. As a result, the stationary distribution  $P^0$  is the equilibrium measure for this class of cascade systems.

## 2. Probability flux vanishing in equilibrium

Typically, KFEs such as that in Eq. (21) can be written in the conservation form

$$\partial_t P = \mathcal{G}^\dagger P = - \sum_{j=1}^N [\partial_{x_j} J_{x_j} + \partial_{y_j} J_{y_j}], \quad (42)$$

expressed in terms of a probability flux  $\mathbf{J} \equiv (J_{x_j}, J_{y_j})$ . In addition, if the system described by such a KFE possesses an equilibrium measure, the flux  $\mathbf{J}$  can be chosen so that it vanishes on this measure. Below, we find an appropriate flux for the system of a single quartet. Note that the vanishing of this flux is the analog of the vanishing energy flux in the thermodynamic equilibrium of weakly-turbulent wave systems. In both cases, we say that such system has achieved *detailed balance*.

The first candidate for the probability flux  $\mathbf{J}$  to give rise to the KFE (21) is

$$\mathbf{J} \equiv (J_{x_j}, J_{y_j}) = \left( \mu_{x_j} P - \frac{\sigma_j^2}{4} \partial_{x_j} P, \mu_{y_j} P - \frac{\sigma_j^2}{4} \partial_{y_j} P \right), \quad (43)$$

and one would expect that  $\mathbf{J}$  should vanish when the probability distribution  $P$  becomes the equilibrium Gaussian measure  $P^0$ , but this is not the case. For the system of a single quartet, from Eq. (22), it is easy to conclude that  $J_{x_q}(P_s^0) = T_q \text{Im}(a_q^* a_p a_{p'}) P_s^0 \neq 0$ , and  $J_{y_q}(P_s^0) = -T_q \text{Re}(a_q^* a_p a_{p'}) P_s^0 \neq 0$ . In fact, no probability distribution can make the flux  $\mathbf{J}$  vanish. Namely, if  $J_{x_q}(P_s) = J_{y_q}(P_s) = 0$  for some distribution  $P_s$ , then  $P_s$  must simultaneously be proportional to each of the four functions  $\exp[(-2\nu_q(x_q^2 + y_q^2) + (4T_q/\sigma_q^2) \text{Im}(a_q^* a_q^* a_p a_{p'}))]$ , with the proportionality factors that do not further depend on the variables  $x_q$  and  $y_q$  (but could depend on the other three pairs  $x_p, y_p$ , where  $p \neq q$ ). However, this cannot be true for all the wave numbers in a single quartet, because the interaction tensors  $T_q$  are distinct and the term  $\text{Im}(a_q^* a_q^* a_p a_{p'})$  involves all the variables and has the opposite signs for  $q = 1, 2$  and  $q = 3, 4$ .

The same situation appears at first in the polar coordinates, in which Eq. (33) can be written in the conser-

vation form

$$\partial_t \tilde{P}_s = \tilde{G}_s^\dagger \tilde{P}_s = - \sum_{j=1}^4 \left[ \partial_{\rho_j} \tilde{J}_{\rho_j} \right] - \partial_\phi \tilde{J}_\phi$$

where

$$\begin{aligned} \tilde{\mathbf{J}} &\equiv (\tilde{J}_{\rho_j}, \tilde{J}_\phi) \\ &= \left( \mu_{\rho_j} \tilde{P}_s - \frac{\sigma_j^2}{4} \partial_{\rho_j} \tilde{P}_s, \mu_\phi \tilde{P}_s - \sum_{j=1}^4 \frac{\sigma_j^2}{4\rho_j^2} \partial_\phi \tilde{P}_s \right) \end{aligned} \quad (44)$$

is the first assumed probability flux. One can again show that  $\tilde{\mathbf{J}}$  does not vanish for any probability distribution.

Because the probability flux satisfying the conservation form is not unique, we instead consider the modified flux

$$\begin{aligned} \tilde{\mathbf{J}}' &\equiv (\tilde{J}'_{\rho_j}, \tilde{J}'_\phi) \\ &= \left( \tilde{J}_{\rho_j} - I_{\rho_j} \tilde{P}_s, \tilde{J}_\phi + \sum_{j=1}^4 \int_{\pi/2}^\phi \partial_{\rho_j} (I_{\rho_j} \tilde{P}_s) d\phi \right) \end{aligned} \quad (45)$$

where  $\tilde{\mathbf{J}}$  is as in Eq. (44) and  $I_{\rho_q} = \pm T_q \rho_1 \rho_2 \rho_3 \rho_4 \sin(\phi) / \rho_q$  (+ is used for  $q = 1, 2$  and - is used for  $q = 3, 4$ ). The resulting conservation equation

$$\partial_t \tilde{P}_s = \tilde{G}_s^\dagger \tilde{P}_s = - \sum_{j=1}^4 \left[ \partial_{\rho_j} \tilde{J}'_{\rho_j} \right] - \partial_\phi \tilde{J}'_\phi$$

is again the KFE (33). We can show that this flux vanishes on the Gaussian equilibrium measure (34),  $\tilde{\mathbf{J}}'(\tilde{P}_s^0) = 0$ . This result brings out the fact that, for describing the cascade model in equilibrium, the physically meaningful probability flux is more suitably defined (as  $\tilde{\mathbf{J}}'$ ) in polar coordinates.

For a system composed of multiple quartets that admits the existence of a Gaussian equilibrium measure, one can appropriately modify the naive guess for the flux in the polar form, as we did in Eq. (45), so that it vanishes on this measure. The better suitability of the polar representation in describing the cascade model will be revisited in Section IV.

Because, as we have just shown, cascade systems in equilibrium achieve detailed balance, we will from here on refer to conditions in Eq. (25) and Eq. (28), as well as their counterparts for systems comprising more than two quartets, as the *detailed-balance conditions*. As we will see in the next section, the detailed-balance conditions also determine the thermodynamic equilibrium in the analogous and/or underlying weakly-turbulent wave systems.

### C. Relation to wave turbulence theory

In this section, we relate the results we have obtained for the equilibrium cascade model to their counterparts

in wave, or weak, turbulence theory. To properly understand this relation, we first note that we can recast the detailed-balance conditions (25), (28) for the cascade model in terms of the wave spectrum

$$n_j^0 \equiv \int \rho_j^2 P^0 dA = \frac{1}{\gamma_j}. \quad (46)$$

In particular, these conditions can be recast as

$$\frac{T_q}{n_q^0} + \frac{T_{q'}}{n_{q'}^0} - \frac{T_p}{n_p^0} - \frac{T_{p'}}{n_{p'}^0} = 0. \quad (47)$$

Moreover, the entropy-evolution equations, Eq. (40) or Eq. (41), confirm that the condition (47) is essential for the cascade model to approach the statistical equilibrium.

The form (47), in which we recast the detailed-balance conditions (25) and (28) in the previous paragraph, points to the conclusion that our results have not been obtained by coincidence, but in fact reflect a common feature of wave-turbulence systems in thermal equilibrium [11]. Here, we illustrate this feature on the example of the MMT model (2). For this model's wave spectrum,  $N_k(t) \equiv \langle |\hat{\psi}_k(t)|^2 \rangle_0$ , where  $\langle \cdot \rangle_0$  denotes the statistical average over the initial Gaussian distribution, under the near-Gaussianity assumption due to the weak nonlinearity, the following kinetic equation was derived [14]:

$$\begin{aligned} \frac{\partial N_k}{\partial t} &= 4\pi \int |k_1 k_2 k_3 k|^{5/2} N_1 N_2 N_3 N_k \\ &\times \left( \frac{1}{N_k} + \frac{1}{N_3} - \frac{1}{N_2} - \frac{1}{N_1} \right) \delta(|k_1|^\alpha + |k_2|^\alpha - |k_3|^\alpha - |k|^\alpha) \\ &\times \delta(k_1 + k_2 - k_3 - k) dk_1 dk_2 dk_3. \end{aligned} \quad (48)$$

Using this kinetic equation, we can derive the time derivative of the wave-system entropy,

$$\mathcal{S}[N_k] \equiv \int \log(N_k) dk, \quad (49)$$

to be

$$\begin{aligned} \frac{d}{dt} \mathcal{S}[N_k] &= \pi \int |k_1 k_2 k_3 k|^{5/2} N_1 N_2 N_3 N_k \\ &\times \left( \frac{1}{N_k} + \frac{1}{N_3} - \frac{1}{N_2} - \frac{1}{N_1} \right)^2 \delta(|k_1|^\alpha + |k_2|^\alpha - |k_3|^\alpha - |k|^\alpha) \\ &\times \delta(k_1 + k_2 - k_3 - k) dk_1 dk_2 dk_3 dk \geq 0. \end{aligned} \quad (50)$$

Note that, in Eq. (49), the entropy is given in terms of the wave spectrum instead of the probability distributions of the wave variables, which appears different from the usual definition using a probability distribution. However, if we assume that the real and imaginary parts of the wave amplitude  $\hat{\psi}_k(t)$  are statistically independent, identically-distributed Gaussian random variables with distribution  $Q_k(s)$ , and that all waves with different wavenumbers  $k$  are statistically independent from

one-another, we derive in Appendix C that the entropy  $\mathcal{S}[N_k]$  equals  $-\int Q_k(s) \log Q_k(s) dk ds$ , up to an additive constant, provided we equate  $N_k$  to the second moment of the resulting distribution for  $\hat{\psi}_k(t)$ . In fact, the wave-system entropy  $\mathcal{S}[N_k]$  is widely used in the weak-turbulence theory, in which the probability distribution of the wave amplitudes is, or at least approaches, near-Gaussian [14, 24]. It is this near-Gaussianity that therefore enables us to use the wave-system entropy for determining the statistical equilibrium of the MMT model, as we elaborate in the next paragraph.

The spectrum  $N_k^0 \equiv \theta/|k|^\alpha$ , where  $\theta$  denotes the temperature, satisfies the equation

$$\frac{1}{N_k^0} + \frac{1}{N_3^0} - \frac{1}{N_2^0} - \frac{1}{N_1^0} = 0, \quad (51)$$

and makes both Eq. (48) and Eq. (50) vanish. It is thus an equilibrium spectrum that maximizes the entropy. In fact, this spectrum  $N_k^0$  is the Rayleigh-Jeans distribution arising from the Gibbs measure. We emphasize that Eq. (51) is equivalent to the resonance condition (3) with  $\Omega(k) = |k|^\alpha$ , and, for the MMT model, to the detailed-balance condition (47). Namely, in the MMT model, the interaction tensor  $T_q = \pm 2|k_1 k_2 k_3 k_4|^{\beta/4}$  is the same for all four wavenumbers  $k_q$ ,  $q = 1, \dots, 4$ , which implies that Eq. (51) contains the same information as Eq. (47).

The above result also immediately holds for other wave equations in which the interaction tensor,  $T_q = T(k_1, k_2, k_3, k_4)$ , is symmetric under permutations of the wavenumbers  $k_1, k_2, k_3$ , and  $k_4$ . However, the detailed-balance condition in Eq. (47) also holds for the thermodynamic equilibrium in a more general class of weakly-turbulent systems without the proper interaction-tensor symmetry. For such systems, in the kinetic equation (48), the expression in parentheses is replaced by the left-hand side of the detailed-balance equation (47) [25]. Finding the corresponding thermodynamic equilibrium thus entails solving a possibly complicated system of functional equations for the wave spectrum  $N_k^0$ , consisting of Eq. (47) together with the resonance conditions (3). One simple example is the case in which  $T_q = F(\omega(k_q))$  as for the hyperbolic PDE in Section II A 2. In this case, from the resonance condition (3b) and the detailed-balance condition (47), we conclude that the Rayleigh-Jeans spectrum in the thermodynamic equilibrium is determined by the equation  $N_k^0 \equiv \theta F(\omega(k))/\omega(k)$ , where  $\theta$  again denotes the temperature. [Cf. also the kinetic equations (62), (63) below.]

An immediately recognizable difference between the cascade model and a turbulent wave system in a detailed-balance thermal equilibrium is that the former is driven and damped while the latter evolves freely. However, one must note that the cascade model in this case does not describe an entire wave system in detailed balance, but only one of its sub-systems, with the influence of the rest of the wave system on this sub-systems's modes represented by the white-noise driving and damping. The detailed-balance conditions of the type described by Eqs. (25)

and (28) thus ensure that this balance does not only exist among the modes represented explicitly in the cascade model, but also between these and the unresolved modes represented by the appropriate amounts of driving and damping determined by these conditions. Moreover, we should re-emphasize that the functional form of the detailed-balance conditions in both types of systems is the same.

We should also again stress the important role of Gaussianity in both systems. In particular, as shown in Section III B 1, under the detailed-balance conditions, any initial distribution of the cascade model will approach the appropriate Gaussian equilibrium measure at long times. The same is true in weakly-turbulent systems. While for the derivation of the appropriate kinetic equation only the random-phase assumption is needed [11], the distribution of the long-time wave profiles was shown to approach Gaussian [24]. (In the MMT model, near-Gaussianity was verified numerically in [14].) The white-noise forcing and damping in the cascade model used in order to mimic a sub-system of a weakly-turbulent system in thermal equilibrium is crucial here: without forcing and damping, a (Hamiltonian) system describing a finite number of interacting waves may exhibit statistics very different from Gaussian.

As we have just seen, the cascade model in equilibrium and its equilibrium measure are closely connected with wave turbulence in thermodynamic equilibrium. Therefore, it is also natural to expect that the study of the non-equilibrium dynamics exhibited by our cascade model may be helpful in understanding such dynamics of wave-turbulence systems, as well.

#### IV. CASCADE MODEL IN NON-EQUILIBRIUM STEADY STATE

In this section, we study the statistical behavior of the cascade model whose parameters do not allow it to approach an equilibrium Gaussian invariant measure, but may admit a non-equilibrium steady state. Such a model does not satisfy the detailed-balance conditions (25), (28) (or their analogs for a system consisting of more than two quartets). Focusing on the systems of single or double quartets unless otherwise specified, we resort to the kinetic theory to approximate an appropriate four-point correlation function of the wave-modes in order to derive a closed set of kinetic equations for the dynamics of the second moments of the wave-mode amplitudes. In a steady state, we use these second moments to approximate the higher moments of the non-shared modes. For the shared wave in the double-quartet cascade model, we demonstrate that it is distributed according to the Gaussian law in two ways. First, we numerically corroborate that the computed moments of the shared-mode amplitude agree with the relations satisfied by the moments of the Gaussian distribution. Second, we construct an auxiliary model in which the shared mode is driven

and damped, show that the marginal distributions of its shared-mode amplitude is Gaussian, and take a distinguished limit in which the driving and damping of this mode vanish to conclude that the Gaussian distribution also governs the statistics of the shared mode in the underlying double-quartet cascade model. Finally, we use an information theoretic argument, akin to entropy maximization, to indicate that this marginal distribution should be the long-time asymptotic limit of all other initial marginal distributions.

### A. Kinetic approach to the cascade model

In this section, we derive approximate kinetic equations governing the second-moment dynamics of the mode amplitudes in the cascade model. We first determine the role that a four-point correlation function of the waves in a quartet plays in characterizing the energy transfer among these resonant waves. We then use an effective time-scale separation between the time-scales governed by the nonlinearity and driving-damping to approximate this four-point function as a function of the second moments of the wave amplitudes, which enables us to derive a closed set of kinetic equations. For the non-shared wave-mode amplitudes in a statistical steady state, we can then derive the expressions for all the higher moments. For the shared wave-mode amplitude, we cannot derive explicit expressions for its higher moments, but we can numerically corroborate that the relations among these moments satisfy the assumption that its distribution is Gaussian.

#### 1. Four-point correlation function and wave-action flux

When the detailed-balance conditions (25), (28) are not met, a theoretical analysis of KFE (21), (31) becomes significantly less tractable. Therefore, instead of studying the joint probability distribution of the cascade model, we turn our attention to the moments of the wave amplitude,  $\langle \rho_j^m \rangle$ , where  $m > 0$  is an integer. Under the assumption that, as  $\rho_j \rightarrow \infty$ , both  $\tilde{P}$  and  $\partial_{\rho_j} \tilde{P}$  tend to zero sufficiently fast, so that  $\rho_j^m \tilde{P}$  and  $\rho_j^m \partial_{\rho_j} \tilde{P}$  approach zero as well, for the system of a single quartet, we derive the equation

$$\partial_t \langle \rho_q^m \rangle = m \left[ m \frac{\sigma_q^2}{4} \langle \rho_q^{m-2} \rangle - \nu_q \langle \rho_q^m \rangle \pm T_q \langle \rho_q^{m-2} \rho_1 \rho_2 \rho_3 \rho_4 \sin(\phi) \rangle \right] \quad (52)$$

using Eq. (33) along with integration by parts. Here, + is used for  $q = 1, 2$  and - is used for  $q = 3, 4$ .

When  $m = 2$ , Eq. (52) describes the time-evolution of the second moment, or wave-action, given by

$$\partial_t \langle \rho_q^2 \rangle = \sigma_q^2 - 2\nu_q \langle \rho_q^2 \rangle \pm 2T_q \langle \rho_1 \rho_2 \rho_3 \rho_4 \sin(\phi) \rangle. \quad (53)$$

In a statistical steady-state, Eq. (53) gives rise to an equation for the stationary power spectra

$$n_q \equiv \langle \rho_q^2 \rangle = \frac{\sigma_q^2 \pm 2T_q \mathcal{I}_s}{2\nu_q} \quad (54)$$

which contains the four-point function

$$\mathcal{I}_s \equiv \langle \rho_1 \rho_2 \rho_3 \rho_4 \sin(\phi) \rangle = \langle \text{Im}(a_1^* a_2^* a_3 a_4) \rangle. \quad (55)$$

In the class of systems whose solutions approach the equilibrium governed by the Gaussian equilibrium measure  $P_s^0$  in Eq. (22) [or, equivalently,  $\tilde{P}_s^0$  in Eq. (34)], which we investigated in Section III, it is easy to derive, using Eq. (24) and the absence of the resonant phase  $\phi$  from the equilibrium measure, that the equilibrium spectrum satisfies Eq. (54) with  $\mathcal{I}_s = 0$ . Thus, for a system in a non-equilibrium steady state, a non-zero value of the four-point function  $\mathcal{I}_s$  represents the deviation of the stationary spectrum (54) from the equilibrium spectrum (46).

In the system of double quartets, the four-point function plays a yet clearer physical role. In particular, in this system, the moments of the driven-damped modes satisfy an equation similar to Eq. (52), while for the shared-mode we derive the equation

$$\partial_t \langle \rho_{4'}^m \rangle = m \left[ -T_{4'} \langle \rho_{4'}^{m-2} \rho_1 \rho_2 \rho_3 \rho_{4'} \sin(\phi') \rangle + T_{4'}' \langle \rho_{4'}^{m-2} \rho_{4'} \rho_5 \rho_6 \rho_7 \sin(\varphi) \rangle \right] \quad (56)$$

using Eq. (36) along with integration by parts. Physically, Eq. (56) indicates that the cascade model can reach a steady-state only if the shared mode, from which driving and damping are absent, gains the same amount energy via the interaction with one quartet as it loses to the other quartet. In particular, Eq. (56) in the case of  $m = 2$  reads

$$\partial_t \langle \rho_{4'}^2 \rangle = 2 \left[ -T_{4'} \langle \rho_1 \rho_2 \rho_3 \rho_{4'} \sin(\phi') \rangle + T_{4'}' \langle \rho_{4'} \rho_5 \rho_6 \rho_7 \sin(\varphi) \rangle \right] \equiv 2(-T_{4'} \mathcal{I}_d + T_{4'}' \mathcal{I}_d') \quad (57)$$

and this equation indicates that the evolution of the second moment of the shared mode is determined by the two four-point functions,  $\mathcal{I}_d$  and  $\mathcal{I}_d'$ . Physically, the expression on the right-hand side of Eq. (57) corresponds to the wave-action (and thus also energy) flux in and out of the shared mode. In particular, we see that in a non-equilibrium statistical steady state, i.e., when the right-hand side of Eq. (57) vanishes but the four-point functions do not, and when the sign of  $T_{4'} \mathcal{I}_d$  (or equivalently  $T_{4'}' \mathcal{I}_d'$ ) is negative, there exists an energy cascade from the quartet  $\{(k_1, k_2), (k_3, k_{4'})\}$  to the quartet  $\{(k_{4'}, k_5), (k_6, k_7)\}$ , i.e., from the upper to the lower quartet in the right panel of Fig. 1.

## 2. Closed kinetic equations for wave-action

In this section we derive kinetic equations that approximate the dynamics exhibited by the second moments  $n_j = \langle \rho_j^2 \rangle$  of the cascade-model modes in a non-equilibrium statistical steady state. Our strategy is to derive closures for the equations, such as Eqs. (53) or (57), that describe the dynamics of these moments. We derive these closures by approximating the four-point functions, such as  $\mathcal{I}_s$ ,  $\mathcal{I}_d$ , or  $\mathcal{I}'_d$ , in terms of the second moments  $\langle \rho_j^2 \rangle$ . By substituting these approximations into Eqs. (53) and (57), we are led to a system of kinetic ODEs for the wave spectra.

Approximate descriptions of non-equilibrium wave systems using kinetic equations can frequently be obtained via a multiple time-scale analysis. For the cascade model, this approach to the kinetic description is similar to the approach used in the kinetic theory of weakly-nonlinear dispersive waves [11]. More precisely, the evolution of a dynamical variable in the system described by Eqs. (10), (11) consists of two parts: one due to the driving and damping (quantified by  $\sigma_j$ ,  $\nu_j$ ) and the other due to the four-wave interactions (quantified by  $T_j$ ). We have seen that when the detailed-balance conditions (25) and (28) hold, the system allows for Gaussian distribution of modes, the equilibrium distribution purely induced by the driving-damping, and thus behaves as if there were no interactions among the waves. When these conditions do not hold but are nearly satisfied, the nonlinear interactions begin to weakly affect the dynamics of the system. As a result, their contribution to the time average of any dynamical variable is negligible on relatively short time-intervals and becomes nontrivial only on very long time-intervals. In other words, the typical time-scale due to the nonlinear interactions is much longer than that due to the driving-damping. Invoking the ergodicity assumption to replace the statistical average by the time average, we use this sharp time-scale separation in the cascade model to approximate the four-point functions in terms of the second moments, and thus derive the kinetic equation.

For two dynamical variables  $X$  and  $Y$  that are uncorrelated in equilibrium, the average of their product can be approximated by the product of the averages of each variable, i.e.,

$$\langle XY \rangle \simeq \langle X \rangle \langle Y \rangle, \quad (58)$$

due to the assumption of near-Gaussianity. In particular, we have

$$\langle \rho_i^m \rho_j^n \rangle \simeq \langle \rho_i^m \rangle \langle \rho_j^n \rangle, \quad (59)$$

for integer  $m$ ,  $n$  ( $> 0$ ) and  $i \neq j$ . The approximation in Eq. (59) becomes less accurate for large  $m$ ,  $n$  because the time interval required for obtaining a good approximation of the statistical average by the time average must be longer. At these longer times, however, the nonlinear interactions disturb the independent Gaussian distributions.

Using Eqs. (10), (11) and (58), we obtain the approximation

$$\begin{aligned} & i\partial_t \langle a_q^* a_{q'}^* a_p a_{p'} \rangle \\ & \simeq -\langle T_q |a_{q'}|^2 |a_p|^2 |a_{p'}|^2 + T_{q'} |a_q|^2 |a_p|^2 |a_{p'}|^2 \\ & \quad - T_p |a_q|^2 |a_{q'}|^2 |a_{p'}|^2 - T_{p'} |a_q|^2 |a_{q'}|^2 |a_p|^2 \rangle \quad (60) \\ & - i \left( \sum_j \nu_j \right) \langle a_q^* a_{q'}^* a_p a_{p'} \rangle, \end{aligned}$$

where  $\sum_j \nu_j$  denotes the sum of the damping parameters for a given quartet. For example, this sum represents  $\sum_{j=1}^4 \nu_j$  for the system of a single quartet, and  $\sum_{j=1}^3 \nu_j$  for  $\{(q, q'), (p, p')\} = \{(1, 2), (3, 4')\}$ ,  $\sum_{j=5}^7 \nu_j$  for  $\{(q, q'), (p, p')\} = \{(4', 5), (6, 7)\}$  for the system of double quartets. In equilibrium, as described in Section III, the left-hand side of Eq. (60) would vanish, while the two terms of the right-hand side would be finite. Thus, under the near-Gaussianity assumption, we may likewise neglect this left-hand side, and use Eq. (59) to obtain an approximation for the four-point function,

$$\begin{aligned} & \langle \rho_q \rho_{q'} \rho_p \rho_{p'} \cos(\theta_{p'} + \theta_p - \theta_{q'} - \theta_q) \rangle \simeq 0, \quad (61a) \\ & \langle \rho_q \rho_{q'} \rho_p \rho_{p'} \sin(\theta_{p'} + \theta_p - \theta_{q'} - \theta_q) \rangle \\ & \simeq \frac{1}{\sum_j \nu_j} \left[ n_q n_{q'} n_p n_{p'} \left( \frac{T_q}{n_q} + \frac{T_{q'}}{n_{q'}} - \frac{T_p}{n_p} - \frac{T_{p'}}{n_{p'}} \right) \right], \quad (61b) \end{aligned}$$

in terms of the spectra  $n_j \equiv \langle \rho_j^2 \rangle$ .

Using Eqs. (61), we can derive a closed equation for the *approximate values* of the spectra  $n_j$ . In particular, the substitution of Eq. (61b) into Eq. (53) yields the kinetic equation

$$\begin{aligned} \frac{\partial n_q(t)}{\partial t} & = \sigma_q^2 - 2\nu_q n_q \\ & + \frac{2T_q}{\sum_j \nu_j} \left[ n_q n_{q'} n_p n_{p'} \left( \frac{T_q}{n_q} + \frac{T_{q'}}{n_{q'}} - \frac{T_p}{n_p} - \frac{T_{p'}}{n_{p'}} \right) \right] \quad (62) \end{aligned}$$

for the driven-damped modes. Similarly, Eq. (57) for the shared-mode spectrum can be approximated as

$$\begin{aligned} \frac{\partial n_{4'}(t)}{\partial t} & = -\frac{2T_{4'}}{\sum_{j=1}^3 \nu_j} \left[ n_1 n_2 n_3 n_{4'} \left( \frac{T_1}{n_1} + \frac{T_2}{n_2} - \frac{T_3}{n_3} - \frac{T_{4'}}{n_{4'}} \right) \right] \quad (63) \\ & + \frac{2T'_{4'}}{\sum_{j=5}^7 \nu_j} \left[ n_{4'} n_5 n_6 n_7 \left( \frac{T'_{4'}}{n_{4'}} + \frac{T_5}{n_5} - \frac{T_6}{n_6} - \frac{T_7}{n_7} \right) \right]. \end{aligned}$$

One can generalize this derivation of Eq. (62) for the driven-damped modes and Eq. (63) for the shared modes (without driving-damping) to cascade systems of more than two quartets.

The ODEs in Eqs. (62), (63) form a set of kinetic equations analogous to the kinetic integro-differential equations derived and studied in the theory of wave turbulence [11, 25–29]. [Cf. Eq. (48) for the MMT model in

Section III C.] The above derivation shows that, in contrast to wave turbulence, the applicability of our kinetic equations is not limited to the case of weakly-nonlinear interactions, i.e., the values of the interaction coefficients  $T_j$  do not have to be small as long as the system can be assumed to reside in the regime of near-Gaussianity. In cases in which a cascade model with a small number of quartets would suffice to glean some particular property of energy transfer, Eqs. (62), (63) would likely afford computational savings in studying that property over direct numerical simulations of the wave system.

We should note that both the perturbation methods used to bring out resonant interactions in the examples presented in Section II A, as well as the classical derivations of kinetic equation in continuous models of weak turbulence [11, 25–27], only include the dominant wave interaction mechanisms, which, for our examples, were resonant quartets. Less prominent interaction mechanisms are neglected, or captured at the higher-order in the perturbation expansion. The cascade model should be able to capture these mechanisms in its driving and damping terms, which would leave the form of the kinetic equations (62) and (63) unchanged. On the other hand, in discrete systems, such as those obtained in numerical simulations of weakly turbulent processes, the dominant role is played not by resonant but near-resonant interactions. While the derivation and the form of the kinetic equation changes in this case [28, 29], triads or quartets remain the basic mode-interaction mechanism. Therefore, our cascade model (or its triad counterpart) should also perform well at modeling the dominant near-resonant interactions in discret(iz)e(d) systems.

### 3. Examples of non-equilibrium steady-state solutions

We are particularly interested in possible stationary solutions of the kinetic equations (62), (63) for the cascade model. In the case of a single quartet, we only need to solve a system of four algebraic equations for four unknowns  $n_j$ , glanced from the right-hand side of Eq. (62). A yet better method is to solve just one algebraic equation for one unknown,  $\mathcal{I}_s$ , obtained by substituting Eq. (54) into Eq. (62). Similarly, for the system of double quartets, one can replace the system obtained from the right-hand sides of Eqs. (62), (63) for seven unknowns  $n_j$  by a system of two algebraic equations for two unknowns,  $\mathcal{I}_d$ ,  $n_{4'}$ , using Eqs. (54) and (57). This drastic dimensional reduction is extremely helpful not only in finding a stationary solution of our kinetic equations, but also when verifying its uniqueness.

We here examine the validity of our kinetic equation (62), (63) via numerical simulations. We consider a system of double quartets in which the interaction tensors  $T_1 = T_2 = T_3 = T_{4'}$  are all equal to 0.1, and  $T'_{4'} = T_5 = T_6 = T_7$  are all equal to 0.2. We fix  $\nu_j$  as 1.0, and vary the parameter  $\Delta\sigma$  satisfying  $\sigma_1 = 1.0 + 2.0 \times \Delta\sigma$ ,  $\sigma_2 = 1.0 + 1.2 \times \Delta\sigma$ ,  $\sigma_3 = 1.0$ ,

$\sigma_5 = 1.0$ ,  $\sigma_6 = 1.0 - 1.5 \times \Delta\sigma$  and  $\sigma_7 = 1.0 - 1.7 \times \Delta\sigma$ . When both  $\sigma_j$  and  $\nu_j$  are the same for all modes, i.e.,  $\Delta\sigma = 0$ , the system is in equilibrium and the four-point functions  $\mathcal{I}_d$ ,  $\mathcal{I}'_d$  vanish. Therefore,  $\Delta\sigma$  can be used to measure the deviation from the equilibrium state. As  $\Delta\sigma > 0$  increases, the energy cascade from the upper quartet to the lower quartet in the right panel of Fig. 1 strengthens.

For a progression of  $\Delta\sigma$  values, we numerically integrate Eqs. (10), (11) using the Euler-Maruyama method with the time step  $\Delta t = 0.0025$ . We compute the four-point functions  $\mathcal{I}_d$ ,  $\mathcal{I}'_d$  and the wave spectra  $n_j = \langle \rho_j^2 \rangle$  via averaging over both time and noise realizations. The time interval for the averaging ranges from  $1.0 \times 10^5$  to  $2.0 \times 10^5$  and the number of realizations is chosen as 50. We compare these numerically-measured statistical quantities with the theoretical predictions from our kinetic equation. In all cases, Eqs. (62), (63) allow for a unique solution,  $n_{4'}$  and  $\mathcal{I}_d$ , for which the spectra  $n_j$  of Eq. (54) are positive. Fig. 3 reveals that the theoretical predictions are in good agreement with the numerically measured four-point functions,  $\mathcal{I}_d$ ,  $\mathcal{I}'_d$ , and wave spectra,  $n_1$ ,  $n_{4'}$ , for a wide range of  $\Delta\sigma$ .

### 4. Higher-order moments of the wave amplitude

In order to compute these moments, we consider the approximation

$$i\partial_t \langle |a_q|^{m-2} (a_q^* a_q^* a_p a_{p'}) \rangle \simeq 0 \quad (64)$$

which holds exactly in the equilibrium case. Using a method similar to the one presented in the preceding section, together with Eq. (64), we obtain an analog of Eq. (61b):

$$\begin{aligned} & \langle \rho_q^{m-2} \rho_q \rho_{q'} \rho_p \rho_{p'} \sin(\theta_{p'} + \theta_p - \theta_{q'} - \theta_q) \rangle \\ & \simeq \frac{1}{\sum_j \nu_j} \left[ n_{q'} n_p n_{p'} \left( \frac{T_{q'}}{n_{q'}} - \frac{T_p}{n_p} - \frac{T_{p'}}{n_{p'}} \right) \langle \rho_q^m \rangle \right. \\ & \quad \left. + T_q n_{q'} n_p n_{p'} \langle \rho_q^{m-2} \rangle \right]. \end{aligned} \quad (65)$$

When the wave  $a_q$  is driven-damped, the substitution of Eq. (65) into Eq. (52) yields the approximation

$$\langle \rho_q^{m+2} \rangle \simeq \frac{(m+2) \frac{\sigma_q^2}{4} + \frac{T_q^2}{\sum_j \nu_j} n_{q'} n_p n_{p'}}{\nu_q - \frac{T_q}{\sum_j \nu_j} n_{q'} n_p n_{p'} \left( \frac{T_{q'}}{n_{q'}} - \frac{T_p}{n_p} - \frac{T_{p'}}{n_{p'}} \right)} \langle \rho_q^m \rangle \quad (66)$$

for a steady-state system. We insert the value of  $n_q \equiv \langle \rho_q^2 \rangle$ , obtained by solving our kinetic equations (62), (63) into Eq. (66) with  $m = 2$  to approximate the value of  $\langle \rho_q^4 \rangle$ . This fourth-order moment, in turn, gives us an approximation of  $\langle \rho_q^6 \rangle$ . By repeating this procedure, we approximate all even-order moments  $\langle \rho_q^{2m} \rangle$  using Eq. (66).



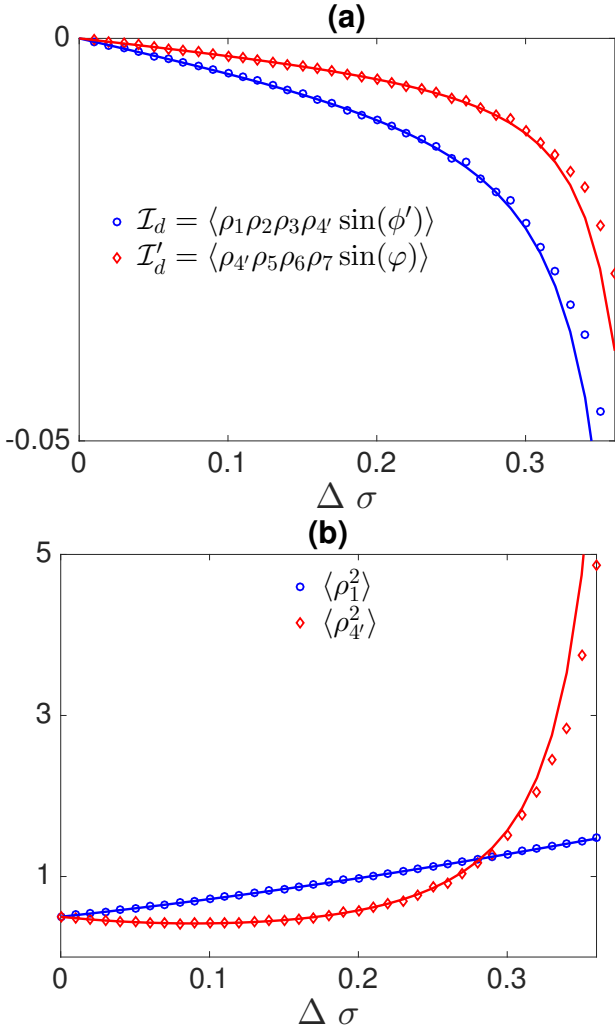

FIG. 3: Top panel: numerically measured  $\mathcal{I}_d$ (circles) and  $\mathcal{I}'_d$ (diamonds) as functions of  $\Delta\sigma$  for the system of double quartets. Bottom panel: numerically measured  $\langle \rho_1^2 \rangle$ (circles) and  $\langle \rho_{4'}^2 \rangle$ (diamonds) as functions of  $\Delta\sigma$  for the system of double quartets. In both cases, the solid lines are the solutions of Eq. (62), (63)

This recurrence relation can also be used to approximate the odd-order moments  $\langle \rho_q^{2m-1} \rangle$ , once the first moment  $\langle \rho_q \rangle$  is available. One of its approximations can be obtained using  $\langle \rho_q \rangle \simeq (\sqrt{\pi}/2) \langle \rho_q^2 \rangle^{1/2}$  under the near-Gaussianity assumption.

For the system of double quartets, we compare the theoretical predictions of the higher-order moments for the driven-damped modes with the moments estimated numerically. We continue to use the same setting as in the previous case and fix  $\Delta\sigma = 0.20$ , for which our kinetic equation yields very accurate predictions. Fig. 4 shows that the analytical approximations of  $\langle \rho_1^m \rangle$  obtained from the solution of Eq. (62), (63) alongside the relation (66) are in good agreement with the numerically measured ones, for any  $1 \leq m \leq 9$ . The agreement tends to be less accurate for the higher-order moments as compared

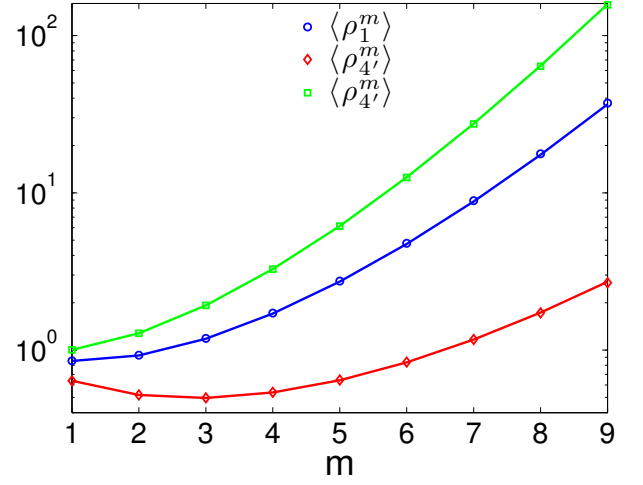

FIG. 4: Numerically measured  $\langle \rho_1^m \rangle$ (circles),  $\langle \rho_{4'}^m \rangle$ (diamonds) when  $\Delta\sigma = 0.20$ , and  $\langle \rho_{4'}^m \rangle$ (squares) when  $\Delta\sigma = 0.30$ , as functions of  $m$  for the system of double quartets. The solid lines are the theoretical predictions using Eq. (66) for  $\langle \rho_1^m \rangle$  and Eq. (67) for  $\langle \rho_{4'}^m \rangle$ .

with the lower-order moments, because Eqs. (59), (66) become less accurate as the power  $m$  grows.

Unfortunately, Eq. (66) cannot be applied to approximate the higher-order moments  $\langle \rho_{4'}^m \rangle$  of the shared mode due to the inherent nature of this mode, i.e., the absence of driving-damping. Thus, the kinetic approach developed so far can only predict the second moment of the shared-mode amplitude, and even that only in a limited parameter regime [see the bottom panel of Fig. (3)]. Since we have designed the shared wave in the cascade model to be reminiscent of the modes in an inertial range in wave turbulence, and so are particularly interested in its statistics, we change tack and first proceed with numerical experiments. As discussed below, we find from these experiments that the shared-wave amplitude  $\rho_{4'}$  is distributed according to the Gaussian law also in a non-equilibrium steady state.

We analyze the outcome of these numerical experiments by noting that, when the marginal distribution of the amplitude  $\rho_{4'}$  is Gaussian, the relation

$$\langle \rho_{4'}^m \rangle = \Gamma\left(\frac{m}{2} + 1\right) \langle \rho_{4'}^2 \rangle^{\frac{m}{2}} \quad (67)$$

is known to be satisfied. Here  $\Gamma(\cdot)$  denotes the Gamma function [30]. When  $\Delta\sigma = 0.20$ , we insert the stationary solution  $n_{4'} \equiv \langle \rho_{4'}^2 \rangle$ , obtained from our kinetic equation (62), (63), into the right-hand side of Eq. (67). In this way, we theoretically predict moments  $\langle \rho_{4'}^m \rangle$ . Up to the 9-th order, these predicted moments give excellent agreement with their counterparts computed by direct numerical simulations of Eqs. (10), (11). (Note that this prediction also includes  $m = 1$ .) We also examine the case of  $\Delta\sigma = 0.30$ , for which our kinetic equation can no longer accurately predict the value of second moment  $\langle \rho_{4'}^2 \rangle$ , as seen from Fig. 3. As we there-

fore possess no analytical tools to accurately approximate  $\langle \rho_{4'}^2 \rangle$  in this parameter regime, we instead substitute its numerically-measured value into Eq. (67) to compute approximations of the higher moments  $\langle \rho_{4'}^m \rangle$  based on the near-Gaussianity assumption. Again, as displayed in Fig. 4, these semi-empirical, Gaussian-based higher-moment approximations agree very well with the numerically-measured higher moments at any order  $m \leq 9$ . We thus tentatively conclude that the system possesses a Gaussian stationary marginal distribution of the shared-mode amplitude. In the next section, we amplify this result by predicting this marginal distribution via a complementary approach using the KFE.

### B. Marginal distribution of the shared-mode amplitude

In this section, we apply an alternative approach to demonstrate that the amplitude of the shared mode in a cascade system of double quartets in a non-equilibrium steady state is distributed according to the Gaussian law. To this end, we first recall the equilibrium case, i.e., the family of cascade models satisfying the detailed-balance conditions in Eq. (28), for which the KFE (36) possesses a joint Gaussian stationary solution described by Eq. (37). One might expect that it would also be possible to derive and analyze a second order PDE, similar to the KFE, which would govern the marginal distribution  $\tilde{P}_d(t, \rho_{4'})$ . However, as we will see below, this attempt is hampered by the fact that the shared wave is free from driving and damping. The key idea to get around this intractable point in the theoretical analysis is to let the shared wave be externally forced and dissipated. We are then allowed to study the statistics of the shared mode utilizing the KFE of this new, auxiliary dynamical system. Finally, we remove both driving and damping that we had imposed on this mode, by letting them vanish via a distinguished limit taken along a particular curve in the driving-damping plane, to recover the cascade model. This roundabout approach provides a framework that leads us to re-examine the known Gaussian statistics in equilibrium from a different perspective, and to predict the non-equilibrium stationary distribution of the shared-mode amplitude.

#### 1. Augmented model

We construct a new, auxiliary model with white noise forcing and linear dissipation added to the shared wave of the double-quartets cascade model. We name this class of systems the *augmented* model. For instance, the augmented model comprising double quartets is the same as the one displayed in the right panel of Fig. 1, except that the wave  $a_{4'}$  is governed by the equation

$$i\partial_t a_{4'} = T_{4'} a_3^* a_1 a_2 + T_{4'}^* a_5^* a_6 a_7 - i\nu_{4'} a_{4'} + \sigma_{4'} \dot{W}_{4'}. \quad (68)$$

Let  $\hat{P}_d$  be the probability distribution and  $\hat{\mathcal{G}}_d$  be the infinitesimal generator [similar to  $\tilde{\mathcal{G}}_d$  in Eq. (35)] of this new system in polar coordinates. (From now on, it will be helpful to keep in mind that  $\tilde{P}$  is used to denote distributions in the cascade model and  $\hat{P}$  in the augmented model.) The SDEs (10), (68) then give rise to the KFE

$$\partial_t \hat{P}_d(t, \{\rho_j, \phi', \varphi\}) = \hat{\mathcal{G}}_d^\dagger \hat{P}_d(t, \{\rho_j, \phi', \varphi\}) \quad (69)$$

for the augmented model. The marginal distribution of the mixed-mode amplitude,

$$\hat{P}_d(t, \rho_{4'}) \equiv \int \hat{P}_d(t, \{\rho_j, \phi', \varphi\}) \prod_{\substack{j=1 \\ j \neq 4}}^7 d\rho_j d\phi' d\varphi,$$

then satisfies the equation

$$\begin{aligned} \partial_t \hat{P}_d(t, \rho_{4'}) &= \int \partial_t \hat{P}_d(t, \{\rho_j, \phi', \varphi\}) \prod_{\substack{j=1 \\ j \neq 4}}^7 d\rho_j d\phi' d\varphi \\ &= \int \hat{\mathcal{G}}_d^\dagger \hat{P}_d(t, \{\rho_j, \phi', \varphi\}) \prod_{\substack{j=1 \\ j \neq 4}}^7 d\rho_j d\phi' d\varphi \\ &= - \int \partial_{\rho_{4'}} \left( \mu'_{\rho_{4'}} \hat{P}_d(t, \{\rho_j, \phi', \varphi\}) \right. \\ &\quad \left. - \frac{\sigma_{4'}^2}{4} \partial_{\rho_{4'}} \hat{P}_d(t, \{\rho_j, \phi', \varphi\}) \right) \prod_{\substack{j=1 \\ j \neq 4}}^7 d\rho_j d\phi' d\varphi, \end{aligned} \quad (70)$$

where the coefficient  $\mu'_{\rho_{4'}}$  is given by the expression

$$\begin{aligned} \mu'_{\rho_{4'}} &\equiv \frac{\sigma_{4'}^2}{4\rho_{4'}} - \nu_{4'} \rho_{4'} \\ &\quad - T_{4'} \rho_1 \rho_2 \rho_3 \sin(\phi') + T_{4'}^* \rho_5 \rho_6 \rho_7 \sin(\varphi). \end{aligned}$$

In general, Eq. (70) is not a closed equation. However, the independence assumption

$$\hat{P}_d(\rho_j, \phi', \varphi) = \hat{P}_d(\rho_{4'}) \hat{P}_d(\rho_j \setminus \rho_{4'}, \phi', \varphi) \quad (71)$$

where  $\rho_j \setminus \rho_{4'} = \{\rho_j \mid j = 1, \dots, 7; j \neq 4\}$  gives rise to the closed PDE:

$$\begin{aligned} \partial_t \hat{P}_d(t, \rho_{4'}) &= \partial_{\rho_{4'}} \left[ \frac{\sigma_{4'}^2}{4} \partial_{\rho_{4'}} \hat{P}_d(t, \rho_{4'}) - \left( \frac{\sigma_{4'}^2}{4\rho_{4'}} - \nu_{4'} \rho_{4'} \right. \right. \\ &\quad \left. \left. - \langle T_{4'} \rho_1 \rho_2 \rho_3 \sin(\phi') - T_{4'}^* \rho_5 \rho_6 \rho_7 \sin(\varphi) \rangle' \right) \hat{P}_d(t, \rho_{4'}) \right]. \end{aligned} \quad (72)$$

Here and after,  $\langle \cdot \rangle'$  denotes the statistical average over the distribution of the augmented model.

There are two issues that we must address with regard to the derivation of Eq. (72). First, condition (71) does not imply that the variable  $a_{4'}$  is independent of the remaining variables. That independence would follow from

assuming  $\widehat{P}_d(x_j, y_j) = \widehat{P}_d(x_{4'}, y_{4'})\widehat{P}_d(x_j \setminus x_{4'}, y_j \setminus y_{4'})$ , where  $x_j \setminus x_{4'} = \{x_j | j = 1, \dots, 7; j \neq 4\}$  and  $y_j \setminus y_{4'} = \{y_j | j = 1, \dots, 7; j \neq 4\}$ , which would be a stronger assumption. In fact, this issue is closely related to the discussion in Section III B 2, i.e., the question of why polar coordinates are more appropriate for the description of the cascade model than rectangular coordinates. Second, Eq. (70) is trivial when  $\sigma_{4'} = \nu_{4'} = 0$ , and therefore there is no second-order PDE analogous to Eq. (72) for the cascade model, as we pointed out above.

In what is to follow, we will use a distinguished limit of this augmented model, in which the driving and damping of the shared mode are made to vanish along a specific curve, in order to approach the marginal distribution of this mode in the limiting cascade system in a non-equilibrium steady state, and demonstrate that it is Gaussian.

## 2. The augmented and cascade models in equilibrium

Starting with a cascade model, we now set up a distinguished, one-parameter family of augmented models that will limit on this cascade model. Choosing this family so that, for each augmented model in it, the marginal distribution of the shared mode is the same, we can use it to characterize the marginal distribution of the shared mode in the underlying cascade model. For clarity and illustration purposes, in this section, we first set this distinguished limit up in the case when the cascade model can reach a Gaussian equilibrium steady state.

We begin by again considering the augmented model, described by Eq. (69), letting  $\gamma_j = 2\nu_j/\sigma_j^2$ , except for  $j = 4$ , as in Eq. (24), and supposing there exists a positive value  $\bar{\gamma}^0$  satisfying the pair of equations

$$\begin{aligned} T_1\gamma_1 + T_2\gamma_2 - T_3\gamma_3 - T_{4'}\bar{\gamma}^0 &= 0, \\ T_{4'}\bar{\gamma}^0 + T_5\gamma_5 - T_6\gamma_6 - T_7\gamma_7 &= 0. \end{aligned} \quad (73)$$

If the value of the parameter

$$\bar{\gamma} \equiv \frac{2\nu_{4'}}{\sigma_{4'}^2} \quad (74)$$

equals  $\bar{\gamma}^0$ , then one can show that the equilibrium distribution of the augmented model comprising double quartets is given by the expression

$$\begin{aligned} \widehat{P}_d^0(\rho_j, \phi', \varphi) \\ \equiv \left(2\bar{\gamma}^0 e^{-\bar{\gamma}^0 \rho_{4'}^2} \rho_{4'}\right) \left(\frac{1}{2\pi}\right)^2 \prod_{\substack{j=1 \\ j \neq 4}}^7 \left(2\gamma_j e^{-\gamma_j \rho_j^2} \rho_j\right) \end{aligned} \quad (75)$$

in a manner similar to what we did in Section III A. This expression leads to the marginal distribution

$$\widehat{P}_d^0(\rho_{4'}) \equiv \int \widehat{P}_d^0(\rho_j, \phi', \varphi) \prod_{\substack{j=1 \\ j \neq 4}}^7 d\rho_j d\phi' d\varphi = 2\bar{\gamma}^0 e^{-\bar{\gamma}^0 \rho_{4'}^2} \rho_{4'} \quad (76)$$

of the shared wave-mode amplitude  $\rho_{4'}$ , which is Gaussian. Note that the distribution (75) satisfies the independence condition (71), as well as gives rise to the equation

$$\langle T_{4'}\rho_1\rho_2\rho_3 \sin(\phi') \rangle' = \langle T_{4'}\rho_5\rho_6\rho_7 \sin(\varphi) \rangle' = 0. \quad (77)$$

Consistently, in this case, Eq. (72) possesses the unique stationary solution given by the expression in Eq. (76).

Let us now consider a cascade model in thermal equilibrium. As we recall from Section III A, the combinations  $\gamma_j$  in Eq. (24) of this model's driving and damping parameters  $\sigma_j$  and  $\nu_j$ ,  $j = 1, \dots, 7$ ,  $j \neq 4$ , together with some positive number  $\gamma_{4'}$ , must satisfy the detailed-balance conditions in Eq. (28). Its equilibrium distribution is, in polar coordinates, given by the function  $\widehat{P}_d^0(\rho_j, \phi', \varphi)$  in Eq. (37), and, consequently, the marginal distribution of its shared-mode amplitude  $\rho_{4'}$  is given by the Gaussian  $\widehat{P}_d^0(\rho_{4'})$  in Eq. (38). Given this cascade model, let us consider an augmented model instantiated by the exact same parameters, except  $\sigma_{4'}$  and  $\nu_{4'}$  (which do not exist in the cascade model). For this augmented model, let its parameter combinations  $\gamma_j$  in Eq. (24) and  $\bar{\gamma}$  in Eq. (74) satisfy the detailed-balance equations (73), so that  $\bar{\gamma} = \bar{\gamma}_0$ . Furthermore, let  $\bar{\gamma}_0 = \gamma_{4'}$ , so that the detailed-balance conditions in Eq. (28) and Eq. (73) become identical. Then the two respective sets of variables and, consequently, the two shared-wave amplitudes are distributed identically. In other words, the two equilibrium distributions,  $\widehat{P}_d^0(\rho_j, \phi', \varphi)$  in Eq. (75) and  $\widehat{P}_d^0(\rho_j, \phi', \varphi)$  in Eq. (37), are given by the same function, and consequently also the two marginal distributions,  $\widehat{P}_d^0(\rho_{4'})$  in Eq. (38) and  $\widehat{P}_d^0(\rho_{4'})$  in Eq. (76), are given by the same function.

To set up the distinguished limit, given a cascade model in equilibrium, let us pick a family of augmented models, characterized by the common value of the parameter  $\bar{\gamma} = \bar{\gamma}_0 = \gamma_{4'}$  and by decreasing parameters  $\sigma_{4'}$  and  $\nu_{4'}$ . In particular, we consider the limiting case of this family in which we take the distinguished limit  $\sigma_{4'}, \nu_{4'} \rightarrow 0$  while still maintaining the same value of their combination  $\bar{\gamma}$  in Eq. (74) at  $\bar{\gamma} = \bar{\gamma}_0 = \gamma_{4'}$ . In other words, we let  $\sigma_{4'}, \nu_{4'}$  vanish along the curve in the  $(\sigma_{4'}, \nu_{4'})$ -plane defined by Eq. (74) with  $\bar{\gamma} = \bar{\gamma}_0 = \gamma_{4'}$ . By approaching this distinguished limit, we gradually reduce the randomness originating from the driving-damping of the shared mode, so that it becomes more and more negligible and the vast majority of the randomness in the system becomes induced by the resonant interactions. Thus, eventually, the augmented models become indistinguishable from, and in the limit  $\sigma_{4'}, \nu_{4'} \rightarrow 0$  turn into, the given cascade model, for which the statistics of the shared-mode amplitude  $\rho_{4'}$  are purely determined by the resonant interactions.

The above distinguished limiting process clearly leaves the probability distributions  $\widehat{P}_d^0(\rho_j, \phi', \varphi)$  and  $\widehat{P}_d^0(\rho_{4'})$  of the augmented model in Eqs. (75) and (76) invariant, since they only depend on the forcing strengths  $\sigma_j$  and

damping strengths  $\nu_j$  (including  $\sigma_{4'}$  and  $\nu_{4'}$ ) through their combinations  $\gamma_j$ ,  $j \neq 4$ , and  $\bar{\gamma}$ , which remain constant. Therefore, in this distinguished limit, we recover the probability distributions  $\tilde{P}_d^0(\rho_j, \phi', \varphi)$  and  $\tilde{P}_d^0(\rho_{4'})$  in Eqs. (37) and (38) with  $\gamma_{4'} \equiv \bar{\gamma}_0$ , belonging to the cascade system of double quartets we have considered in the first place. In particular, for the marginal distribution of the shared-mode amplitude  $\rho_{4'}$ , this distinguished limit yields the equation

$$\tilde{P}_d^0(\rho_{4'}) = \lim_{\substack{\sigma_{4'}, \nu_{4'} \rightarrow 0 \\ 2\nu_{4'}/\sigma_{4'}^2 = \bar{\gamma}^0}} \hat{P}_d^0(\rho_{4'}) \quad (78)$$

where, as just mentioned, we use the invariance of the distribution  $\hat{P}_d^0(\rho_{4'})$  over the distinguished family.

We should remark that, in the equilibrium case studied in this section, the above distinguished limiting process was trivial. Namely, the probability distributions for all the variables in both the cascade model and the associated distinguished family of augmented models in equilibrium are known explicitly, as is the limit of the latter distribution onto the former. This will definitely not be true in the next section, in which we will use a similar type of distinguished-limit approach to study the marginal distribution of the shared mode of the double-quartet cascade model in a non-equilibrium steady state.

### 3. The augmented and cascade models in non-equilibrium steady state

In this section, we use the idea we employed in the preceding section to study the marginal distribution of the shared-wave amplitude for the double-quartet cascade model in a non-equilibrium steady state via a distinguished limit of a corresponding family of augmented models.

Unlike in the equilibrium case, discussed in the previous section, for which our distinguished limit is only a means of further highlighting the properties of the exactly-obtained equilibrium measure, our use of the distinguished limit in the non-equilibrium steady state of the cascade model is unavoidable. This is because, as we pointed out in the last paragraph of Section IV B 1, in such a state, we could find no dynamical equation that would govern the marginal distribution of the shared-mode amplitude.

Let us first focus on the augmented model of double quartets. Even for this model, if the detailed-balance conditions (73) for the equilibrium do not hold, we cannot obtain an explicit expression for its non-equilibrium steady-state distribution. Instead, we derive the steady-state distribution of its shared-mode amplitude using properties of its moments. In particular, for the moments of the shared-mode amplitude  $\rho_{4'}$ , from the KFE (69),

using integration by parts, we compute the equations

$$\begin{aligned} \partial_t \langle \rho_{4'}^m \rangle' = m & \left[ m \frac{\sigma_{4'}^2}{4} \langle \rho_{4'}^{m-2} \rangle' - \nu_{4'} \langle \rho_{4'}^m \rangle' \right. \\ & - \langle T_{4'} \rho_{4'}^{m-2} \rho_1 \rho_2 \rho_3 \rho_{4'} \sin(\phi') \rangle' \\ & \left. - T_{4'}' \rho_{4'}^{m-2} \rho_{4'} \rho_5 \rho_6 \rho_7 \sin(\varphi) \right]'. \end{aligned} \quad (79)$$

[Cf. Eqs. (52) and (56).]

In a statistical steady-state, Eq. (79) with  $m = 1$  gives rise to the equation

$$\begin{aligned} & \langle T_{4'} \rho_1 \rho_2 \rho_3 \sin(\phi') - T_{4'}' \rho_5 \rho_6 \rho_7 \sin(\varphi) \rangle' \\ & = \frac{\sigma_{4'}^2}{4} \langle \rho_{4'}^{-1} \rangle' - \nu_{4'} \langle \rho_{4'} \rangle'. \end{aligned} \quad (80)$$

If we again make the independence assumption (71) for the joint probability distribution  $\hat{P}_d(\rho_j, \phi', \varphi)$  of the augmented model in this state, we note that the Gaussian distribution

$$\hat{P}_d^1(\rho_{4'}) \equiv 2\bar{\gamma} e^{-\bar{\gamma} \rho_{4'}^2} \rho_{4'}, \quad (81)$$

where the parameter  $\bar{\gamma}$  satisfies Eq. (74), makes the right-hand side of Eq. (80) vanish, which further implies the equation

$$\langle T_{4'} \rho_1 \rho_2 \rho_3 \sin(\phi') - T_{4'}' \rho_5 \rho_6 \rho_7 \sin(\varphi) \rangle' = 0. \quad (82)$$

In turn, when the equation (82) is satisfied for a joint distribution  $\hat{P}_d(\rho_j, \phi', \varphi)$  that also satisfies the independence assumption (71), the resulting equation in Eq. (72) allows for the unique stationary solution given by Eq. (81). Thus, we conclude that any augmented model in a non-equilibrium steady state, whose corresponding joint distribution  $\hat{P}_d(\rho_j, \phi', \varphi)$  satisfies the independence assumption (71), necessarily possesses the Gaussian distribution in Eq. (81) as the marginal distribution of its shared-mode amplitude  $\rho_{4'}$ .

Turning our attention to the cascade model, we begin by considering a distinguished limit of an appropriate family of augmented models, all of which find themselves in a non-equilibrium steady state. In particular, we choose a family of the augmented models sharing identical parameter values except for  $\nu_{4'}$  and  $\sigma_{4'}$ ; for these two parameters, the ratio  $\bar{\gamma} (\equiv 2\nu_{4'}/\sigma_{4'}^2)$  is identical for the entire family. In the distinguished limit of vanishing driving-damping while keeping  $\bar{\gamma}$  constant, the form of the marginal Gaussian distribution in Eq. (81) remains invariant. This invariance, as in the equilibrium case, allows us to define a formal limit, which we denote by

$$\tilde{P}_d^1(\rho_{4'}) \equiv \lim_{\substack{\sigma_{4'}, \nu_{4'} \rightarrow 0 \\ 2\nu_{4'}/\sigma_{4'}^2 = \bar{\gamma}}} \hat{P}_d^1(\rho_{4'}). \quad (83)$$

In order to understand which distinguished family of augmented models we should associate with a given

double-quartet cascade model, we notice that, for all these augmented models, the parameter  $\bar{\gamma}$  ( $\equiv 2\nu_{4'}/\sigma_{4'}^2$ ) in the Gaussian distribution (81) equals the reciprocal of its second moment. Therefore, the appropriate choice of the distinguished augmented-model family corresponding to the chosen cascade model is such that the parameter  $\bar{\gamma}$  of this family equals  $\gamma$ , which satisfies the equation

$$\langle \rho_{4'}^2 \rangle = \frac{1}{\bar{\gamma}}. \quad (84)$$

Here, the stationary second moment  $\langle \rho_{4'}^2 \rangle$  for the cascade model is obtained as the appropriate component of the corresponding fixed point of the kinetic-equation system (62), (63) provided such a fixed point exists. Together with Eq. (84), the formal limit (83) and the Gaussian form (81) provide us with a strong indication that the stationary shared-mode amplitude distribution of the given double-quartet cascade model should be given by the Gaussian form

$$\tilde{P}_d^1(\rho_{4'}) = 2\gamma e^{-\gamma\rho_{4'}^2} \rho_{4'}. \quad (85)$$

This indication is amplified by the numerical corroboration that the higher-moment relations of this distribution closely agree with the Gaussian prediction in Eq. (67), as explained at the end of Section IV A 4.

We should note here, however, that the above derivation is formal. Unlike in the equilibrium case, treated in the previous section, in which all the solutions are explicitly known and the distinguished limit is therefore trivial, we made no attempt at proving Eq. (85) rigorously. Moreover, we have not even proven that the distinguished limiting process gives convergence to a solution of the cascade model in a continuous fashion in the case of a non-equilibrium steady state. Nevertheless, we will be content with the above strong indications that the shared-mode amplitude distribution of a double-quartet cascade model in such a state should indeed be the Gaussian in Eq. (85).

We should also note that we use the distinguished limit of the augmented model here solely to demonstrate the Gaussianity of the shared-mode amplitude distribution in a non-equilibrium steady state of a double-quartet cascade model. This limit does not give us a direct way to compute the width of this distribution, and in fact, the limit of the augmented model as  $\sigma_{4'}, \nu_{4'} \rightarrow 0$  without satisfying any constraints is singular. Namely, while we have found that the shared-mode distribution of the augmented model in a non-equilibrium steady state is Gaussian, its width can vary widely in the  $\sigma_{4'}, \nu_{4'} \rightarrow 0$  limit depending on the value of the ratio  $\bar{\gamma} = 2\nu_{4'}/\sigma_{4'}^2$ . In other words, an arbitrarily small addition of driving and damping to the shared mode in the cascade model can, in the resulting augmented model, significantly alter the width of this mode's amplitude distribution in a non-equilibrium steady state.

Before concluding this section, we should remark on the physical importance of certain points in the arguments presented above. In particular, it is important

to notice from Eqs. (74) and (81) that the Gaussian statistics of the shared-mode amplitude in the augmented model are not caused by the resonant interactions among the modes, but are instead completely determined by the forcing and dissipation. (Recall from the previous section that the same property holds in the equilibrium case.) We thus emphasize that Eq. (82) can be viewed as a balance of two resonant interactions, and plays exactly the same critical role in the non-equilibrium system as the detailed-balance condition (73) plays in the equilibrium system. This role is to ensure that the subsystem describing the shared mode behaves as if there were no interactions with other modes, and further possesses a Gaussian stationary distribution of its amplitude. In this regard, we also note that Eq. (77), satisfied by the system in equilibrium, is a special case of Eq. (82).

For the cascade model obtained from the augmented model via the distinguished limit, the balance condition (82) formally gives the limiting balance condition

$$\langle T_{4'} \rho_1 \rho_2 \rho_3 \sin(\phi') - T'_{4'} \rho_5 \rho_6 \rho_7 \sin(\varphi) \rangle = 0. \quad (86)$$

Alternatively, we can obtain the balance in Eq. (86) directly from Eq. (56) with  $m = 1$ , and in particular without resorting to the independence assumption (71) or its possible limit in the cascade model. This fact will be important for the information-theoretic approach presented in the next section. We here also remark that the relation between the balance in Eq. (86) and the detailed-balance condition (28) in the cascade model is analogous to the relation between the balance in Eq. (82) and the detailed-balance condition (73) in the augmented model.

We should also note that the balance condition (82) is closely related to the vanishing of the net wave-action flux into the shared mode of the augmented model in a steady state, as we can deduce from the independence assumption (71), the Gaussian distribution form (81), and Eq. (79) with  $m = 2$ . Its distinguished limit (86) is the vanishing of the right-hand side of Eq. (57), i.e., the vanishing of the difference between the wave-action fluxes into and out of the shared mode of the cascade model in a steady state, which we have already discussed at the end of Section IV A 1. This is a much less restrictive condition than the detailed balance condition (28), or its consequence, the cascade-model limit of Eq. (77), which imply the vanishing of both the fluxes into and out of the shared mode separately.

Under the less restrictive balance condition (86), the wave-action flux through the shared mode in the non-equilibrium steady state of the cascade model equals  $\langle T_{4'} \rho_1 \rho_2 \rho_3 \sin(\phi') \rangle = \langle T'_{4'} \rho_5 \rho_6 \rho_7 \sin(\varphi) \rangle$ , and generally does not vanish. This is reminiscent of the finite-flux, Kolmogorov-Zakharov solutions of the kinetic equation for the inverse (or direct) cascade in weak turbulence, for which the total input flux of either wave-action or energy into a mode also equals its total output flux. For the special, power-law type Kolmogorov-Zakharov solutions [11, 27], which appear in systems with scaling symmetries, more restricted wave-action (or energy) contri-

butions from quadruples of proportional quartets that share a node must already add up to zero [14]. Modeling of such Kolmogorov-Zakharov solutions that describes this property would require a more sophisticated architecture of a coupled-quartet model than our linear cascade, in order to properly capture the underlying symmetry and the resulting self-similarity, which is outside the scope of this paper.

Finally, we should address the question of when a given cascade model possesses a statistical steady state. We know from Sections III A and III B that it possesses an equilibrium precisely when the detailed-balance conditions Eq. (25), Eq. (28), or their counterparts for cascade systems comprising more than two quartets, hold. More generally, the kinetic equations (62), (63) provide a strong indication for the existence or non-existence of a steady state: a steady state is likely to exist for the corresponding cascade model precisely when these equations have a fixed point. We will address possible approach of other initial distributions to such a steady state in the next section.

### C. Information-theoretic approach to relaxation of shared-mode amplitude

Finally, we discuss the long-time behavior of the shared-mode amplitude in the cascade model. Recall that, in a statistical equilibrium, we have addressed the long-time behavior of the entire system via the maximal entropy principle discussed in Section III B 1. There, the key object is the relative entropy  $\mathcal{S}_{\text{EQ}}(P, P^0)$ , defined in Eq. (39). For the system of double quartets satisfying the detailed-balance condition (28), we use Eq. (41) to show that the time-derivative of the corresponding relative entropy  $\mathcal{S}_{\text{EQ}}(P_d, P_d^0)$  in rectangular coordinates is positive semi-definite and vanishes if and only if  $P = P_d(t, \{x_j, y_j\}) = P_d^0(x_j, y_j)$ , the equilibrium distribution in Eq. (26). Likewise, we can use a similar derivation to show that the relative entropy  $\mathcal{S}_{\text{EQ}}(\tilde{P}_d, \tilde{P}_d^0)$  in polar coordinates is positive semi-definite and vanishes if and only if  $\tilde{P}_d(t, \{\rho_j, \phi', \varphi\}) = \tilde{P}_d^0(\rho_j, \phi', \varphi)$ , the equilibrium distribution in Eq. (37). Formally, we represent the monotonic growth of the macroscopic quantity  $\mathcal{S}_{\text{EQ}}(\tilde{P}_d, \tilde{P}_d^0)$  by the statement:

$$\tilde{P}_d(t, \{\rho_j, \phi', \varphi\}) \rightarrow \tilde{P}_d^0(\rho_j, \phi', \varphi) \quad \text{as } t \rightarrow \infty. \quad (87)$$

We should remark here, however, that we have by no means proven pointwise convergence of arbitrar(ily) (rough) distribution functions  $\tilde{P}_d$  towards the equilibrium distribution  $\tilde{P}_d^0$ , given by Eq. (37). Moreover, addressing any precise manner in which possible functional convergence of solutions of the KFE (36) to the distribution  $\tilde{P}_d^0$  in Eq. (37) might take place is beyond the scope of this paper.

For non-equilibrium dynamical systems, there also exist attempts to describe the irreversible relaxation to the

steady state by defining and studying entropy-like quantities [31]. One immediate candidate is obtained by using a non-equilibrium stationary distribution instead of the equilibrium distribution, which reads

$$\begin{aligned} \mathcal{S}_{\text{SS}} \left( \tilde{P}_d(\rho_j, \phi', \varphi), \tilde{P}_d^1(\rho_j, \phi', \varphi) \right) \\ \equiv - \left\langle \log \left( \frac{\tilde{P}_d(\rho_j, \phi', \varphi)}{\tilde{P}_d^1(\rho_j, \phi', \varphi)} \right) \right\rangle \end{aligned} \quad (88)$$

in the case of the cascade model. Here, SS stands for steady-state, and the reference distribution  $\tilde{P}_d^1(\rho_j, \phi', \varphi)$  denotes a time-independent solution of Eq. (36), if it exists, other than  $\tilde{P}_d^0(\rho_j, \phi', \varphi)$ . Naively, one might expect in the non-equilibrium case to use the evolution of the “relative entropy” defined in Eq. (88) to reach a conclusion similar to that in Eq. (87) in the equilibrium case. However, it is known that quantities such as  $\mathcal{S}_{\text{SS}}$  can fail to correctly predict the relaxation process (see, for instance [32]). Furthermore, in the present case, we are unable to examine the validity of the maximization of the relative entropy  $\mathcal{S}_{\text{SS}}$  in Eq. (88) as a means of establishing long-time convergence to the steady-state distribution  $\tilde{P}_d^1(\rho_j, \phi', \varphi)$  simply because we do not even know what  $\tilde{P}_d^1(\rho_j, \phi', \varphi)$  would be.

We instead conclude this paper by pointing out that the condition (86) underlies the monotonic growth of the macroscopic quantity

$$\mathcal{S}_{\text{SS}} \left( \tilde{P}_d(\rho_{4'}), \tilde{P}_d^1(\rho_{4'}) \right) = - \left\langle \log \left( \frac{\tilde{P}_d(\rho_{4'})}{\tilde{P}_d^1(\rho_{4'})} \right) \right\rangle \quad (89)$$

which is maximized when the marginal distribution of the shared-mode amplitude  $\rho_{4'}$  becomes the Gaussian function  $\tilde{P}_d^1(\rho_{4'})$  in Eq. (85), just as the detailed-balance constraint (28) underlies the formal limit (87) in the case of equilibrium. This result may be interpreted as irreversible relaxation of the shared-mode amplitude,  $\rho_{4'}$ , of the cascade model to a non-equilibrium statistical steady state, which we formally denote by the statement:

$$\tilde{P}_d(t, \rho_{4'}) \rightarrow \tilde{P}_d^1(\rho_{4'}) \quad \text{as } t \rightarrow \infty. \quad (90)$$

In order to study the time-evolution of the macroscopic quantity  $\mathcal{S}_{\text{SS}}$  in Eq. (89), we again use our distinguished limit from Sections IV B 2 and IV B 3. We employ the augmented model characterized by the parameter  $\bar{\gamma} = \gamma$  [Cf. Eqs. (74) and (84)], and define the analogous quantity

$$\hat{\mathcal{S}}_{\text{SS}} \left( \hat{P}_d(\rho_{4'}), \hat{P}_d^1(\rho_{4'}) \right) \equiv - \left\langle \log \left( \frac{\hat{P}_d(\rho_{4'})}{\hat{P}_d^1(\rho_{4'})} \right) \right\rangle' \quad (91)$$

where  $\langle \cdot \rangle'$  denotes the statistical average over the distribution of the augmented model. Using Eq. (72), a calculation similar to the one in Appendix B yields the

time derivative of Eq. (91):

$$\begin{aligned} \frac{d}{dt} \widehat{\mathcal{S}}_{\text{SS}} \left( \widehat{P}_d(\rho_{4'}), \widehat{P}_d^1(\rho_{4'}) \right) &= \int \frac{\sigma_{4'}^2}{4\widehat{P}_d(\rho_{4'})} \left( \partial_{\rho_{4'}} \widehat{P}_d(\rho_{4'}) \right. \\ &- \left. \left( \frac{1}{\rho_{4'}} - 2\bar{\gamma}\rho_{4'} \right) \widehat{P}_d(\rho_{4'}) \right)^2 d\rho_{4'} \\ &- \langle T_{4'} \rho_1 \rho_2 \rho_3 \sin(\phi') - T_{4'}' \rho_5 \rho_6 \rho_7 \sin(\varphi) \rangle' \\ &\times \int \left( \frac{1}{\rho_{4'}} - 2\bar{\gamma}\rho_{4'} \right) \widehat{P}_d(\rho_{4'}) d\rho_{4'} \end{aligned} \quad (92)$$

which is positive semi-definite, and vanishes only when when the marginal distribution of the shared-mode amplitude,  $\rho_{4'}$ , of the cascade model becomes  $\widehat{P}_d(\rho_{4'}) = \widehat{P}_d^1(\rho_{4'})$ , provided the condition (82) holds. [Eq. (92) can be regarded as a counterpart of Eq. (41)]. Applying the distinguished limit as  $\sigma_{4'}, \nu_{4'} \rightarrow 0$  to the result of the augmented model, using the same approach we used in the previous section, we predict the formal limit in Eq. (90).

We should again emphasize, as we did in the text following Eq (82), that we have derived the balance condition (82) directly and without resorting to any special assumptions on the initial distribution in the cascade model. Therefore, the formal limit should hold regardless of the initial distribution, provided a statistical steady state exists for the cascade model in question. We discussed the conditions for this existence at the end of the previous section.

## V. CONCLUSIONS

In the spirit of shell models of Navier-Stokes turbulence, we have constructed a cascade model of wave turbulence. As the backbone of our construction, we used the natural objects mediating energy transfer in one-dimensional and many higher-dimensional weakly-turbulent wave systems, which are resonant interactions among four waves. The result is a minimal, yet realistically coupled, driven, and damped model that reproduces a number of salient features exhibited by physical systems and their kinetic-theoretic descriptions in wave turbulence. In particular, in addition to a set of driven and damped modes, our cascade model incorporates a coupled sequence of modes free of driving and damping, which are intended to reflect the properties of the wave-modes in the inertial range of a weakly-turbulent wave system.

We first found that the equilibrium case of the cascade model directly corresponds to the thermodynamic equilibrium in wave turbulence. We have been able to show that all the wave amplitudes in this case obey a joint Gaussian distribution law, and also that the appropriately-chosen energy flux among the wave-modes vanishes, as is expected in thermodynamic equilibrium. Moreover, the conditions that need to be imposed on its

parameters for the cascade model to find itself in equilibrium ensure detailed balance, just as the equation characterizing the Rayleigh-Jeans spectra in wave turbulence. Lastly, we derived a maximum-entropy principle for the equilibrium distribution in the cascade model, which corresponds to the maximum-entropy principle for the thermodynamic equilibrium in wave turbulence.

The non-equilibrium steady-state case of the cascade model resembles statistical steady states of weakly-turbulent wave systems in which non-zero energy transfer takes place, such as perhaps states in which these latter systems exhibit Kolmogorov-Zakharov spectra [11]. While a closed-form joint distribution of the variables characterizing the cascade model is impossible to find in this case, we do find an approximate description by deriving a closed set of kinetic ODEs for the second-order amplitude moments of the wave-modes. These ODEs parallel, but are significantly simpler than, the corresponding kinetic equations in wave turbulence. We use the second-order amplitude moments we obtain from the kinetic equations to further find the higher-order amplitude moments of the driven-damped modes and a Gaussian marginal distribution for the coupled modes not subject to any external driving or damping, and thus determine the marginal distributions of all the wave modes in the cascade model also in a non-equilibrium steady state. Again, we find an information-theory-based process resembling an entropy-maximization principle for the Gaussian marginal distribution of the modes without driving or damping.

Altogether, the cascade model sheds new light on and provides details of the energy-transfer mechanisms in wave turbulence, by closely mimicking and carefully taking into account the main features of weakly-turbulent wave systems on the one hand, and being analytically tractable on the other. One ultimate goal of our simplified modeling would be to help to better explain system behavior in realistic wave turbulence, in particular, the steady-state dynamics of modes in an inertial range of such systems, based on the knowledge gained from the non-equilibrium dynamics exhibited by our cascade or related models.

## Acknowledgments

We thank Yuri Lvov for useful discussions. The research of Wonjung Lee is supported by the Start-up Grant of City University of Hong Kong (No. 7200498) and the Early Career Scheme of Hong Kong, Project No. 9048086 (CityU 21302416). The research of Gregor Kovačić is partly supported by the NSF grant DMS1615859. Wonjung Lee and Gregor Kovačić dedicate this paper to the memory of their late coworker and mentor David Cai.

### Appendix A: Multiple time-scale analysis of a hyperbolic PDE

First, we derive Eq. (8) from Eqs. (6), (7) by substituting the formal expansion

$$u = V(x, \epsilon x, t, \epsilon t, \epsilon^2 t) = V_0 + \epsilon V_1 + \epsilon^2 V_2 + \dots \quad (\text{A1})$$

into the hyperbolic PDE

$$[\partial_t^2 + \omega^2(|\partial_x|)] u + \epsilon^2 u^3 = 0, \quad (\text{A2})$$

and employing term-by-term analysis. At the lowest order, the wave equation

$$O(1): \quad [\partial_t^2 + \omega^2(|\partial_x|)] V_0 = 0 \quad (\text{A3})$$

emerges. We substitute the four-wave resonance solution

$$V_0 = \sum_{j=1}^4 B_j(\epsilon x, \epsilon t, \epsilon^2 t) e^{i[k_j x - \omega(k_j)t]}, \quad (\text{A4})$$

and that gives rise to the next-order equation,

$$\begin{aligned} O(\epsilon): \quad & [\partial_t^2 + \omega^2(|\partial_x|)] V_1 \\ & = \sum_{j=1}^4 2i\omega(k_j) \left[ \partial_{\epsilon t} B_j + \frac{\partial \omega(k_j)}{\partial k_j} \partial_{\epsilon x} B_j \right] e^{i[k_j x - \omega(k_j)t]}. \end{aligned}$$

We suppress the secular growth of  $V_1$  by letting the coefficient of the resonant wave vanish, which leads to the transport equation for the wave amplitude  $B_j$  over the time-scale of order  $\epsilon^{-1}$ ,

$$\partial_{\epsilon t} B_j + \frac{\partial \omega(k_j)}{\partial k_j} \partial_{\epsilon x} B_j = 0.$$

Likewise, by suppressing the secular term in the third order equation

$$\begin{aligned} O(\epsilon^2): \quad & [\partial_t^2 + \omega^2(|\partial_x|)] V_2 \\ & = \sum_{j=1}^4 2\omega(k_j) \left[ i\partial_{\epsilon^2 t} B_j - \frac{3}{\omega(k_j)} B_j^* B_k B_{k'} \right. \\ & \quad \left. - \frac{3}{2\omega(k_j)} \left( 2 \sum_{l=1}^4 |B_l|^2 - |B_j|^2 \right) B_j \right] e^{i[k_j x - \omega(k_j)t]} \\ & \quad + \text{non-resonant terms,} \end{aligned}$$

we find Eq. (8).

Next, we use a time-scale separation to study the asymptotic behavior of the hyperbolic PDE

$$[\partial_t^2 + \omega^2(|\partial_x|)] u + \epsilon u^3 = 0, \quad (\text{A5})$$

which has a different amplitude scaling from the one given in Eq. (A2). The substitution of

$$u = V(x, \epsilon x, t, \epsilon t) = V_0 + \epsilon V_1 + \dots \quad (\text{A6})$$

again yields Eq. (A3). If we again assume four waves to be excited, as in Eq. (A4), the resulting equation

$$\begin{aligned} & i\partial_{\epsilon t} B_j + i \frac{\partial \omega(k_j)}{\partial k_j} \partial_{\epsilon x} B_j \\ & = \frac{6}{\omega(k_j)} B_j^* B_k B_{k'} + \frac{3}{\omega(k_j)} \left( 2 \sum_{l=1}^4 |B_l|^2 - |B_j|^2 \right) B_j, \end{aligned}$$

obtained via the suppression of a secular term in the first order equation,

$$\begin{aligned} O(\epsilon): \quad & [\partial_t^2 + \omega^2(|\partial_x|)] V_1 \\ & = \sum_{j=1}^4 2\omega(k_j) \left[ i\partial_{\epsilon t} B_j + i \frac{\partial \omega(k_j)}{\partial k_j} \partial_{\epsilon x} B_j - \frac{6}{\omega(k_j)} B_j^* B_k B_{k'} \right. \\ & \quad \left. - \frac{3}{\omega(k_j)} \left( 2 \sum_{l=1}^4 |B_l|^2 - |B_j|^2 \right) B_j \right] e^{i[k_j x - \omega(k_j)t]}, \end{aligned}$$

is a transport equation with a resonant nonlinear interaction. Therefore, the study of Eqs. (A1), (A2) and Eqs. (A5), (A6) reveals that different scaling of the amplitude leads to different long-time dynamics.

### Appendix B: Positive semi-definiteness of the relative entropy

In this Appendix, we show the equation

$$\begin{aligned} \frac{d}{dt} \mathcal{S}_{\text{EQ}}(P_s, P_s^0) & = \sum_{j=1}^4 \int \frac{4\rho_j^2}{\sigma_j^2 P_s} \left[ \left( \nu_j P_s + \frac{\sigma_j^2}{4\rho_j} \partial_{\rho_j} P_s \right)^2 \right. \\ & \quad \left. + \left( \frac{\sigma_j^2}{4\rho_j^2} \partial_{\theta_j} P_s \right)^2 \right] dA \\ & \quad - 2(T_1 \gamma_1 + T_2 \gamma_2 - T_3 \gamma_3 - T_4 \gamma_4) \int \rho_1 \rho_2 \rho_3 \rho_4 \sin(\phi) P_s dA. \end{aligned} \quad (\text{B1})$$



Using the notation in Eqs. (42), (43), the time evolution of the entropy becomes

$$\begin{aligned}
\frac{d}{dt} \mathcal{S}_{\text{EQ}}(P_s, P_s^0) &= -\frac{d}{dt} \int P_s \log \left( \frac{P_s}{P_s^0} \right) dA \\
&= \int \sum_{q=1}^4 (\partial_{x_q} J_{x_q} + \partial_{y_q} J_{y_q}) \left( \log \left( \frac{P_s}{P_s^0} \right) + 1 \right) dA \\
&= -\sum_{q=1}^4 \int \left[ J_{x_q} \left( \frac{\partial_{x_q} P_s}{P_s} - \frac{\partial_{x_q} P_s^0}{P_s^0} \right) + \right. \\
&\quad \left. J_{y_q} \left( \frac{\partial_{y_q} P_s}{P_s} - \frac{\partial_{y_q} P_s^0}{P_s^0} \right) \right] dA \\
&= \sum_{q=1}^4 \int \frac{4}{\sigma_q^2 P_s} \left[ J_{x_q} (J_{x_q} - T_q \text{Im}(a_{q'}^* a_p a_{p'}) P_s) + \right. \\
&\quad \left. J_{y_q} (J_{y_q} + T_q \text{Re}(a_{q'}^* a_p a_{p'}) P_s) \right] dA \\
&= \left[ \sum_{q=1}^4 \int \frac{4}{\sigma_q^2 P_s} \left[ (J_{x_q} - T_q \text{Im}(a_{q'}^* a_p a_{p'}) P_s)^2 + \right. \right. \\
&\quad \left. \left. (J_{y_q} + T_q \text{Re}(a_{q'}^* a_p a_{p'}) P_s)^2 \right] dA \right] \\
&+ \left[ \sum_{q=1}^4 \int \frac{4}{\sigma_q^2 P_s} \left[ T_q \text{Im}(a_{q'}^* a_p a_{p'}) P_s (J_{x_q} - T_q \text{Im}(a_{q'}^* a_p a_{p'}) P_s) \right. \right. \\
&\quad \left. \left. - T_q \text{Re}(a_{q'}^* a_p a_{p'}) P_s (J_{y_q} + T_q \text{Re}(a_{q'}^* a_p a_{p'}) P_s) \right] dA \right] \\
&:= \mathcal{I}_1 + \mathcal{I}_2.
\end{aligned}$$

Here  $\mathcal{I}_2$  can be separated into

$$\begin{aligned}
\mathcal{I}_2 &= \sum_{q=1}^4 \int \frac{4}{\sigma_q^2 P_s} \left[ T_q \text{Im}(a_{q'}^* a_p a_{p'}) P_s \left( -\nu_q x_q P_s - \frac{\sigma_q^2}{4} \partial_{x_q} P_s \right) \right. \\
&\quad \left. - T_q \text{Re}(a_{q'}^* a_p a_{p'}) P_s \left( -\nu_q y_q P_s - \frac{\sigma_q^2}{4} \partial_{y_q} P_s \right) \right] dA \\
&= -\sum_{q=1}^4 \int \left[ \frac{4T_q \nu_q}{\sigma_q^2} (\text{Im}(a_{q'}^* a_{q'}^* a_p a_{p'})) P_s \right] dA \\
&\quad + \sum_{q=1}^4 \int \left[ T_q \left[ -\text{Im}(a_{q'}^* a_p a_{p'}) \partial_{x_q} P_s \right. \right. \\
&\quad \left. \left. + \text{Re}(a_{q'}^* a_p a_{p'}) \partial_{y_q} P_s \right] \right] dA \\
&:= \mathcal{I}_{21} + \mathcal{I}_{22},
\end{aligned}$$

in which

$$\text{Im}(a_{q'}^* a_{q'}^* a_p a_{p'}) = x_q \text{Im}(a_{q'}^* a_p a_{p'}) - y_q \text{Re}(a_{q'}^* a_p a_{p'})$$

is used. We turn to the polar representation, and make use of

$$\begin{aligned}
\partial_{x_q} &= \frac{x_q}{\rho_q} \partial_{\rho_q} - \frac{y_q}{\rho_q^2} \partial_{\theta_q}, \\
\partial_{y_q} &= \frac{y_q}{\rho_q} \partial_{\rho_q} + \frac{x_q}{\rho_q^2} \partial_{\theta_q}
\end{aligned}$$

and

$$\text{Re}(a_{q'}^* a_{q'}^* a_p a_{p'}) = x_q \text{Re}(a_{q'}^* a_p a_{p'}) + y_q \text{Im}(a_{q'}^* a_p a_{p'})$$

to calculate

$$\mathcal{I}_1 = \sum_{j=1}^4 \int \frac{4}{\sigma_j^2 P} \rho_j^2 \left[ \left( \nu_j P_s + \frac{\sigma_j^2}{4\rho_j} \partial_{\rho_j} P_s \right)^2 + \left( \frac{\sigma_j^2}{4\rho_j^2} \partial_{\theta_j} P_s \right)^2 \right] dA,$$

$$\begin{aligned}
\mathcal{I}_{21} &= -2(T_1 \gamma_1 + T_2 \gamma_2 - T_3 \gamma_3 - T_4 \gamma_4) \\
&\quad \times \int \rho_1 \rho_2 \rho_3 \rho_4 \sin(\phi) P_s dA,
\end{aligned}$$

and

$$\begin{aligned}
\mathcal{I}_{22} &= \sum_{q=1}^4 \int T_q \left[ -\text{Im}(a_{q'}^* a_{q'}^* a_p a_{p'}) \frac{1}{\rho_q} \partial_{\rho_q} P_s \right. \\
&\quad \left. + \text{Re}(a_{q'}^* a_{q'}^* a_p a_{p'}) \frac{1}{\rho_q^2} \partial_{\theta_q} P_s \right] dA \\
&= \sum_{q=1}^4 \int T_q \left[ \mp (\rho_1 \rho_2 \rho_3 \rho_4)^2 \sin(\phi) \frac{1}{\rho_q} \partial_{\rho_q} P_s \right. \\
&\quad \left. + (\rho_1 \rho_2 \rho_3 \rho_4)^2 \cos(\phi) \frac{1}{\rho_q^2} \partial_{\theta_q} P_s \right] \prod_{j=1}^4 d\rho_j d\theta_j \\
&= \sum_{q=1}^4 \int T_q \left[ \pm (\rho_1 \rho_2 \rho_3 \rho_4)^2 \sin(\phi) \frac{1}{\rho_q^2} P_s \right. \\
&\quad \left. - (\rho_1 \rho_2 \rho_3 \rho_4)^2 \partial_{\theta_q} (\cos(\phi)) \frac{1}{\rho_q^2} P_s \right] \prod_{j=1}^4 d\rho_j d\theta_j \\
&= \sum_{q=1}^4 \int T_q \left[ \pm (\rho_1 \rho_2 \rho_3 \rho_4)^2 \sin(\phi) \frac{1}{\rho_q^2} P_s \right. \\
&\quad \left. \mp (\rho_1 \rho_2 \rho_3 \rho_4)^2 \sin(\phi) \frac{1}{\rho_q^2} P_s \right] \prod_{j=1}^4 d\rho_j d\theta_j = 0.
\end{aligned}$$

Here the first sign for  $\pm$  and  $\mp$  is used when  $q = 1, 2$ , and the second one when  $q = 3, 4$ . Therefore, we obtain Eq. (B1).

### Appendix C: Entropy in wave turbulence

For a mechanical system, the entropy is defined as

$$S = - \int P[b] \ln P[b] D b \quad (\text{C1})$$

where  $P[b]$  denotes the ensemble distribution in the phase space,  $b \equiv \{b_1, b_2, \dots\}$  denotes all the phase variables, and  $Db = db_1 db_2 \dots$  [23]. However, in the theory of weak turbulence [11], the entropy is defined as

$$S = \int \ln n_k dk \quad (\text{C2})$$

where  $n_k = \langle a_k a_k^* \rangle$  is the wave action,  $a_k$  denote the (complex) wave-mode variables, and  $\langle \cdot \rangle$  denotes the ensemble average over the initial conditions. We now sketch the underlying reason behind the equivalence of these two expressions.

Consider a probability density function (PDF) consisting of a product of statistically independent phase-variable probability densities for each  $j$ , i.e.,

$$P[b] = \prod_j \zeta_j(b_j),$$

where  $\zeta_j$  are the one-dimensional distributions. For this PDF, the entropy (C1) becomes

$$S = \sum_j \int \prod_m \zeta_m(b_m) \ln \zeta_j(b_j) db_m.$$

For  $m \neq j$ , the corresponding factor in each product becomes  $\int \zeta_m(b_m) db_m = 1$ , so what remains in the sum is

$$S = \sum_j \left( - \int \zeta_j(b_j) \ln \zeta_j(b_j) db_j \right). \quad (\text{C3})$$

In other words, when the phase variables are statistically independent, their total entropy equals the sum of the entropy contributions from each individual phase variable.

In a wave system, if the real and imaginary parts of each wave-mode  $a_k = x_k + iy_k$  are independent and identically distributed, then each term in the above sum (C3) can simply be counted twice, once for  $b_k = x_k$  and the

second time for  $b_k = y_k$ , and so the entropy of the wave system becomes

$$S = \sum_k S_k, \quad S_k \equiv -2 \int \zeta_k(b_k) \ln \zeta_k(b_k) db_k. \quad (\text{C4})$$

If the wave components  $x_k$  and  $y_k$  are both Gaussian-distributed with zero mean and variance  $\langle |a_k|^2 \rangle$ , i.e., obey the distribution

$$\zeta_k(b_k) = \frac{1}{(2\pi \langle |a_k|^2 \rangle)^{1/2}} \exp \left[ -\frac{b_k^2}{2 \langle |a_k|^2 \rangle} \right], \quad b_k = x_k \text{ or } y_k, \quad (\text{C5})$$

then the term  $S_k$  in Eq. (C4) becomes

$$S_k = \frac{1}{(2\pi \langle |a_k|^2 \rangle)^{1/2}} \int_{-\infty}^{\infty} \left[ \ln (2\pi \langle |a_k|^2 \rangle) + \frac{b^2}{\langle |a_k|^2 \rangle} \right] \exp \left[ -\frac{b^2}{2 \langle |a_k|^2 \rangle} \right] db$$

Taking into account that the Gaussian distribution in Eq. (C5) integrates to 1, and realizing that we can eliminate the variance  $\langle |a_k|^2 \rangle$  from the second term in the integral by changing the integration variable to  $b/\langle |a_k|^2 \rangle^{1/2}$ , we finally find the equation

$$S_k = \ln \langle |a_k|^2 \rangle + \text{const.}$$

Ignoring a possibly infinite constant, we can write the total entropy as  $S = \sum_k \ln \langle |a_k|^2 \rangle$ . If we replace the discrete sum over the wave-mode number  $k$  by an integral over a continuous wavenumber, we obtain precisely Eq. (C2), as in the weak turbulence theory [11]. Therefore, the expression for the entropy in Eq. (C2), commonly used in the weak-turbulence theory, emerges as a consequence of the underlying assumption that the real and imaginary components of the waves obey statistically independent Gaussian distributions, identical for the two components of each wave-mode but not necessarily identical from one wave-mode to another.

- 
- [1] A. N. Kolmogorov, in *Dokl. Akad. Nauk SSSR* (1941), vol. 30, pp. 299–303.
- [2] U. Frisch, *Turbulence: the legacy of a. n. kolmogorov* (1995).
- [3] T. Bohr, M. H. Jensen, G. Paladin, and A. Vulpiani, *Dynamical systems approach to turbulence* (Cambridge University Press, 2005).
- [4] J. H. Ferziger and M. Perić, *Computational methods for fluid dynamics*, vol. 3 (Springer Berlin, 1996).
- [5] V. Desnianskii and E. Novikov, *Journal of Applied Mathematics and Mechanics* **38**, 468 (1974).
- [6] E. Gledzer, in *Soviet Physics Doklady* (1973), vol. 18, p. 216.
- [7] A. Obukhov, *Atmos. Oceanic Phys* **10**, 127 (1974).
- [8] M. Yamada and K. Ohkitani, *Physical review letters* **60**, 983 (1988).
- [9] M. Jensen, G. Paladin, and A. Vulpiani, *Physical Review A* **43**, 798 (1991).
- [10] M. Jensen, G. Paladin, and A. Vulpiani, *Physical Review A* **45**, 7214 (1992).
- [11] V. E. Zakharov, V. S. L'vov, and G. Falkovich, *Kolmogorov spectra of turbulence 1. Wave turbulence.*, by Zakharov, VE; L'vov, VS; Falkovich, G.. Springer, Berlin (Germany), 1992, 275 p., ISBN 3-540-54533-6, **1** (1992).
- [12] F. Bretherton, *Journal of Fluid Mechanics* **20**, 457 (1964).
- [13] D. Benney and P. Saffman, *Proceedings of the Royal Society of London. Series A. Mathematical and Physical Sciences* **289**, 301 (1966).
- [14] A. J. Majda, D. W. McLaughlin, and E. G. Tabak, *Jour-*

- nal of Nonlinear Science **7**, 9 (1997).
- [15] D. Cai, A. J. Majda, D. W. McLaughlin, and E. G. Tabak, Proceedings of the National Academy of Sciences **96**, 14216 (1999).
- [16] D. Cai, A. J. Majda, D. W. McLaughlin, and E. G. Tabak, Physica D: Nonlinear Phenomena **152**, 551 (2001).
- [17] P. A. Milewski, E. G. Tabak, and E. Vanden-Eijnden, Studies in Applied Mathematics **108**, 123 (2002).
- [18] R. DeVille, P. A. Milewski, R. J. Pignol, E. G. Tabak, and E. Vanden-Eijnden, Communications on pure and applied mathematics **60**, 439 (2007).
- [19] G. B. Whitham, *Linear and Nonlinear Waves* (John Wiley & Sons, Inc, 1974).
- [20] R. Salmon, *Lectures on geophysical fluid dynamics*, vol. 378 (Oxford University Press Oxford, 1998).
- [21] G. E. Uhlenbeck and L. S. Ornstein, Physical review **36**, 823 (1930).
- [22] C. W. Gardiner and C. Gardiner, *Stochastic methods: a handbook for the natural and social sciences*, vol. 4 (Springer Berlin, 2009).
- [23] R. Ellis, *Entropy, large deviations, and statistical mechanics*, vol. 1431 (Springer, 2005).
- [24] Y. V. Lvov and S. Nazarenko, Physical Review E **69**, 066608 (2004).
- [25] A. C. Newell and B. Rumpf, in *Advances in Wave Turbulence*, edited by V. Shrira and S. Nazarenko (World Scientific, 2013), vol. 83 of *World Scientific Series on Nonlinear Science Series A*, pp. 1–51.
- [26] K. Hasselmann, J. Fluid Mech **12**, 15 (1962).
- [27] V. Zakharov, in *Basic Plasma Physics: Selected Chapters, Handbook of Plasma Physics, Volume 1* (1984), vol. 1, p. 3.
- [28] Y. V. Lvov, S. Nazarenko, and B. Pokorni, Physica D: Nonlinear Phenomena **218**, 24 (2006).
- [29] Y. Pan and D. K. Yue, Journal of Fluid Mechanics **816** (2017).
- [30] G. B. Arfken, H. J. Weber, and F. E. Harris, *Mathematical methods for physicists* (Academic press, 2005).
- [31] J. W. Gibbs, H. A. Bumstead, and W. R. Longley, *The collected works of J. Willard Gibbs*, vol. 1 (Longmans, Green, 1931).
- [32] B. L. Holian, Physical Review A **33**, 1152 (1986).