



CHORUS

This is the accepted manuscript made available via CHORUS. The article has been published as:

Strength of hydroxide catalysis bonds between sapphire, silicon, and fused silica as a function of time

Margot Phelps, Mariela Masso Reid, Rebecca Douglas, Anna-Maria van Veggel, Valentina Mangano, Karen Haughian, Arjen Jongschaap, Meghan Kelly, James Hough, and Sheila Rowan

Phys. Rev. D **98**, 122003 — Published 10 December 2018

DOI: [10.1103/PhysRevD.98.122003](https://doi.org/10.1103/PhysRevD.98.122003)

The strength of hydroxide catalysis bonds between sapphire, silicon, and fused silica as a function of time

Margot Phelps¹, Mariela Masso Reid², Rebecca Douglas², Anna-Maria van Veggel², Valentina Mangano², Karen Haughian², Arjen Jongschaap³, Meghan Kelly², James Hough², and Sheila Rowan²

¹ *Max Planck Institute for Gravitational Physics, Leibniz University, 30167 Hannover, Germany*

² *SUPA, School of Physics and Astronomy, The University of Glasgow, Glasgow, G12 8QQ, UK and*

³ *TU Delft Aerospace Faculty, Kluyverweg 1, 2629 HS Delft, Netherlands*

Hydroxide catalysis bonds have formed an integral part of ground-based gravitational wave observatories since the 1990s. By allowing the creation of quasi-monolithic fused silica mirror suspensions in detectors such as GEO600 and Advanced LIGO, their use was crucial to the first ever direct detection of gravitational waves. Following these successes, this bonding technique has been included in advanced next generation cryogenic detector designs. Currently, they are used to create quasi-monolithic crystalline sapphire suspensions in the KAGRA detector. They are also planned for use in silicon suspensions of future detectors such as the Einstein Telescope. In this paper we report how the strength of hydroxide catalysis bonds evolves over time; and compare the curing rates of bonds as they form between fused silica substrates to those between sapphire to sapphire and silicon to silicon substrates. For bonds between all three types of substrate material we show that newly formed bonds exhibit slightly higher breaking stresses than bonds cured for longer periods of time. We find that the strength stabilises at ≥ 15 MPa for bonds cured for up to 30 weeks (7 months). This finding is important to future cryogenic GW detector design as it is crucial to ensure the long term integrity of the suspension interfaces. Monitoring the strength of bonds that have been allowed to cure for shorter lengths of time can also shed light on the chemistry of bond formation.

I. INTRODUCTION

Hydroxide catalysis bonding is a precise optical joining technique that creates chemical bonds between oxides or oxidisable materials using an aqueous hydroxide solution. This technique can be used to make strong, UHV compatible, and optically clear joints that can be precisely aligned [1, 2]. Originally it was developed and patented for the construction of the Gravity Probe B telescope [3, 4]. Since then it has also been developed as a successful method for creating quasi-monolithic suspensions for ground-based gravitational wave (GW) detectors. These bonds have been a part of room temperature detectors since GEO600 was installed, and has been successfully integrated into the Advanced LIGO, and Virgo detectors [5–7].

Currently, all interferometric ground-based GW detectors consist of multi-stage pendulum suspensions, the last stages of which are quasi-monolithic. In the quasi-monolithic stage of a room temperature aLIGO detector, a fused silica test mass is suspended from a penultimate mass via fused silica fibres, welded to an interface piece, or “ear”. Hydroxide catalysis bonding is used to connect these ears to the test masses, as shown in the aLIGO suspension design in Figure 1.

Following the first few observations of GWs from coalescing black holes and neutron stars by the aLIGO and Virgo detectors [8–13], it is essential to pursue technological advancements that improve the sensitivities of ground-based detectors. One such area of advancement is to pair the operation of detectors at cryogenic temperatures with improvements in mirror and suspension design, aiming to improve detector sensitivity by lessening thermal noise effects.

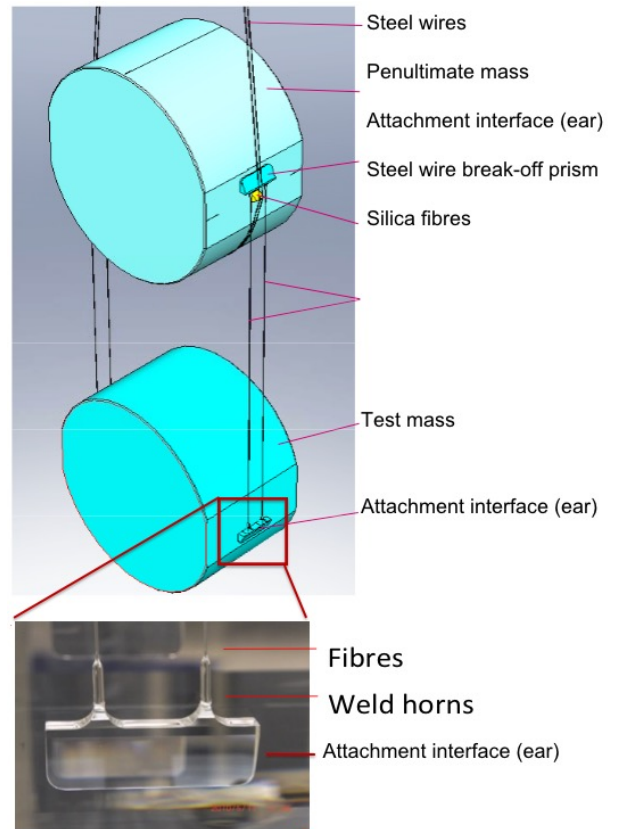

FIG. 1. aLIGO quasi-monolithic fused silica suspension with hydroxide catalysis bonded ear.

These advancements are planned for the ground-based GW detectors of the future, such as the Einstein Tele-

scope (ET) in Europe, and the Voyager detector in the USA [14, 15]. The ET detector is designed to have a factor of 10 improvement in sensitivity, which is proposed to increase the event rate by a factor of 1000 when compared to aLIGO.

The mirror substrates and suspension fibre elements in all detectors that operate at room temperature are comprised of fused silica. However, fused silica exhibits a broad dissipation peak at low temperatures, making it a poor choice for the suspensions and test masses of cryogenic detectors [16, 17]. Thus a change of mirror substrate and suspension material is necessary for the construction of cryogenic detectors. There are two promising candidates for cryogenic mirrors and suspension elements; mono-crystalline sapphire and silicon. The cryogenic KAGRA observatory is under construction and will use sapphire for its test masses and some of its suspension elements [18]. Other future detectors currently in the design phase, such as ET and Voyager, will likely use silicon as a substrate and suspension element material, with sapphire also under consideration [15, 19]. Hydroxide catalysis bonds are presently a part of all the advanced detector suspension designs mentioned here. However, there are differences in the chemistry involved in the formation of bonds between sapphire compared to those that formed between silica or oxidised silicon. Thus the development of bonds between materials for cryogenic detectors such as sapphire or silicon as a function of curing time was investigated. The results of this study are reported in this paper, and compared to past research done on the development of bonds between fused silica.

II. CHEMISTRY OF HYDROXIDE CATALYSIS BOND FORMATION BETWEEN SILICA AND SILICON

The chemistry of how a hydroxide catalysis bond forms between silica or oxidised silicon can be broken down into the same three main steps: etching by hydration, polymerization, and dehydration. A schematic of the interaction between bond solution and substrate surface is shown in Figure 2. A short description of the reaction for bonding silica to silica is given below, the chemistry of which is described more extensively in the original patent by Gwo [4].

First the substrate surface is flooded with a sodium silicate solution. The hydroxide ions in the solution etch the surface, liberating silica which forms $\text{Si}(\text{OH})_5^-$. In this process the number of hydroxide ions decreases which causes the pH of the solution to drop.

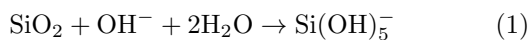

Once the pH of the bond solution drops below a pH of 11 [20], silicate ions dissociate and siloxane chains begin to form.

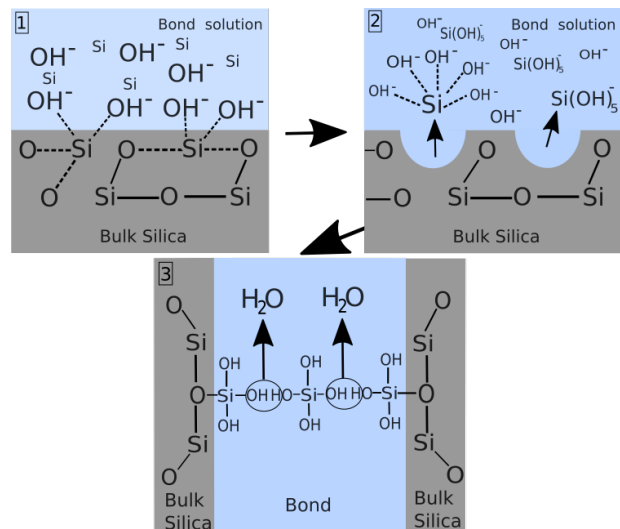
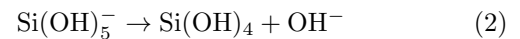

FIG. 2. Bond formation between fused silica. Stage 1 is hydration and etching, where OH^- ions form weak bonds with Si atoms on the surface. Stage 2 shows Si atoms released from the bulk to form $\text{Si}(\text{OH})_5^-$ in the solution. In stage 3 the formation of siloxane chains and water occurs.

First dissociation:



Then the formation of siloxane chains and water occurs:



In the final step of bond curing, water migrates from the bond region, and the bond strength gradually settles over time as it dehydrates.

The initial settling time of silicate bonds is typically 10s of seconds. However the water migration process may take weeks to months [4, 21]. The settling time can be used to precisely align optical components before permanent placement. If the bond quality is poor, they can be de-bonded within a day. As the bond depends on the formation of silicate networks, it follows that silica-based materials can easily be joined using this technique e.g. fused silica, glass, and glass ceramic composites such as Zerodur. Other oxide materials can be bonded if the silicate chain can form covalent bonds onto the substrate surface. Any surface that can be terminated by hydroxyl groups, as in the case of fused silica, is an ideal candidate. The initial extent to which the alkaline bonding solution can etch the substrate surfaces also plays an important role in the quality of the resulting bond.

For a variety of applications it is of interest to bond non-oxide materials, such as silicon. It is known that silicon etches in the presence of an alkaline solution, however one of the products of this reaction is hydrogen gas, which would compromise the formation of a rigid siloxane network [22]. Therefore each silicon surface must

be oxidised to form a sufficient coating of SiO_2 in order to create reliable bonds to it. Deal and Grove [23] describe thermal oxidation of silicon occurring between 800°C and 1200°C . Samples presented here are oxidised at 1000°C for 5 hours, growing an oxide layer of approximately 200 nm. The chemical reaction for this process is $\text{Si} + \text{O}_2 \rightarrow \text{SiO}_2$.

Therefore, the chemistry of hydroxide catalysis bond formation between oxidised silicon substrates follows the same steps as for bonds between fused silica substrates.

III. CHEMISTRY OF HYDROXIDE CATALYSIS BOND FORMATION BETWEEN SAPPHIRE

Mono-crystalline sapphire is chemically very different from amorphous fused silica. The general stages of the bond process are similar to that of bonded silica, which is explained in Section II. However, there are some differences in the chemistry of how the bond forms between sapphire substrates. One difference is that sapphire is a comparatively hard material; etching it via hydroxide ions is a slow process. A bond solution that contains only hydroxide can etch the alumina bond surfaces, however a silicate-like network cannot be formed on the alumina surfaces at a reasonable rate. Thus the sapphire surfaces are hydrated with a silicate rich hydroxide solution (sodium silicate), in order to speed the creation of a stronger bond, where the free alumina ions attach to the silicates in solution, forming a 3D aluminosilicate network.

The hydroxide ions in the sodium silicate solution can interact with the sapphire surface in a few ways, the dominant reaction is explained below in Equations 4-6. A more detailed explanation of the chemical reactions for the formation of hydroxide catalysis bonded sapphire can be found in reference [24]. First the alumina ions are freed from the surface by the hydroxide.

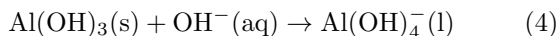

Then the $\text{Al}(\text{OH})_4^-$ ions can begin bond formation via the dimerization process.



As the pH drops, the silicate ions form a silicate like network. The alumina ions in solution will chemically react with this silicate network, as the Al atoms replace some of the Si atoms a 3D aluminosilicate network is formed.

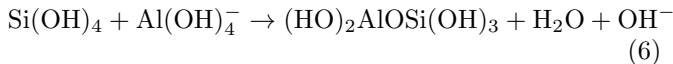

In the final step the water leaves the bond, and the bond strength gradually settles over time.

IV. HYDROGEN BONDS AND THEIR ADDITION TO BOND STRENGTH

After the polymerisation stage of hydroxide catalysis bond formation, the bond interface is full of siloxane chains and H_2O . The role of hydrogen bond formation during this stage should be considered. For a more in-depth analysis see reference [25].

Hydrogen bonds can form between H_2O molecules and the aluminosilicate network or between H_2O and the substrate surfaces. The clean, flat, and hydrophilic bond surfaces that were used encouraged the quick spread of water, indicating a high number of hydrogen bonds would occur in the initial stages of hydroxide catalysis bond formation [26]. In the case of fused silica or oxidised silicon the oxygen and hydrogen atoms on the surface form hydrogen bonds as shown in Figure 3.

Sapphire, Al_2O_3 , also has oxygen molecules that can

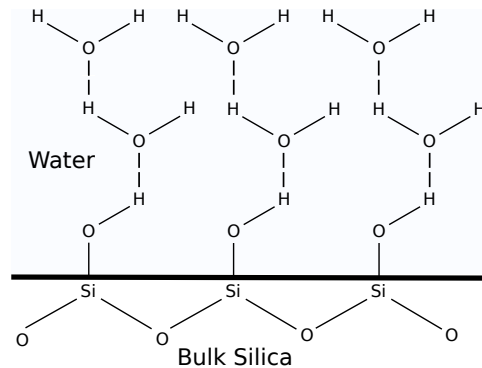

FIG. 3. Hydrogen bonds between water molecules and a fused silica surface. Hydrogen bonds indicated by dashed line, covalent bonds by a solid line.

form hydrogen bonds with water. However, if the sapphire surface is pristine, the oxygen atoms are bound very tightly into its crystal lattice. Hydrogen bonds would not readily form. The sapphire substrates used in this study were mechanically cleaned using cerium oxide prior to bonding, effectively weakening some of the connections between alumina molecules across the surface. This mechanical cleaning is thought to allow the hydroxide catalysis bond to free alumina atoms from the bulk Al_2O_3 substrate in order to form aluminosilicate chains. It also allows water to permeate the partially broken Al_2O_3 connections to form hydrogen bonds with the oxygen atoms. In the literature, the correlation between hydrogen bonds and the improved strength of polymers and fibres has been investigated [27, 28]. In hydroxide catalysis bonds the siloxane or aluminosilicate chains form lattices between the substrates alongside and intertwined with the water molecule's hydrogen bonds, inextricably linking the contributions of the two joining mechanisms.

V. HYDROXIDE CATALYSIS BOND PROCEDURE

Bonded interfaces in GW detector suspensions are required to be thin enough to keep their contributions to the mechanical loss (and thus the thermal noise) of the overall system low enough to satisfy sensitivity requirements. This typically means a bond thickness of ≤ 100 nm is required [29].

To create bonds that are reliably ≤ 100 nm, the surfaces to be joined are polished to a peak-to-valley flatness of $\lambda/10$, where $\lambda = 633$ nm. The outer edges of all bond surfaces are also chamfered to reduce the occurrence of edge defects such as peaks. These edge defects would increase the surface mismatch and flatness. The surface roughness is less important than global flatness. However it is also kept to ≤ 5 nm on average for repeatability [2]. Great care needs to be taken with the characterisation and preparation of the substrate surfaces prior to bonding. All samples in this study were visually inspected for defects, and a subset was measured with callipers near the bond surface to ensure that all bond surfaces were symmetric in size. Peak-to-valley (PV) flatness measurements were taken of all of the bond surfaces in this study with a ZYGO GPI XP/D interferometer [30]. Chamfer dimensions were measured on 10% of the samples, using a Hitachi TM 1000 tabletop Scanning Electron Microscope (SEM) [31]. The sapphire samples in this study had a bond surface of 5 mm x 5 mm, 20 mm long. The silicon and fused silica samples were each 5 mm x 10 mm, 20 mm long. A subset of the samples was randomly selected to have the micro-roughness of their bond surfaces measured, using a Wyko NT1100 white light interferometer [32]. This was to check that the sample's Ra (average deviation from the mean) roughness met the 5 nm rms requirement.

After being characterised, the bond surfaces were cleaned. This process removed residues, organics and particulates, leaving the bond surfaces hydrophilic. Different approaches have been used to attain such surface quality, such as exposure to ozone or acid solutions [33]. However, cleaning with cerium oxide remains the most reliable approach. For repeatability all the sample surfaces of all the bonds reported in this paper were cleaned using cerium oxide.

The cleaning and bonding procedure used here was also used to bond the ears to the test masses in the aLIGO detector [34]. In this approach, de-ionized (DI) or reverse osmosis (RO) water was mixed with cerium oxide and gently rubbed onto the bond surface with an optical wipe. The cerium oxide was then removed from the samples with sodium bicarbonate and rinsed with DI water. Finally, the bond surfaces were rinsed with high-grade methanol and dried with a cleanroom wipe.

The bond solution was made by mixing commercially available sodium silicate solution (Na_2SiO_3 Sigma Aldrich 338443-1L 10.6% NaOH, 26.5% SiO_2 by weight in a water solution[35]) with additional RO water. A ra-

tio of 1:6 silicate solution to water is used to attain a bond solution pH of approximately 12. The bonding solution was then centrifuged and passed through a medical filter with a 0.2 μm pore size. This sodium silicate bond solution was used to create all of the bonds reported in this paper, allowing the bond strengths between each type of material to be comparable with each other.

When the solution was ready, the bond surfaces were visually inspected for contaminants or defects, wiped once more with a cleanroom wipe soaked in high-grade methanol and were placed with the bond surface side up in a metal holder. The bond solution was then pipetted onto the first surface, using a 2-20 μL variable volume Eppendorf pipette with tip ejector [36] to set the amount of solution to suit the bond area. The second sample was then carefully aligned and placed on top of the first one. The bond quality was monitored over several days via visual inspection while the bonds cured at room temperature. Bonds that did not have any visible contaminants or air bubbles across 80% or more of the bond interface are referred to as having a ‘‘bond quality better than 80%’’.

VI. TENSILE STRENGTH TESTING

The tensile strength of each hydroxide catalysis bonded sample was measured using a four-point bending test, following the mechanical testing standard outlined in ASTM C1161-13 [37]. This procedure is an industry standard to test the flexural strength of brittle materials such as fused silica and so has been used in the GW community as a standard to assess the tensile strength of hydroxide catalysis bonded fused silica, sapphire, and silicon for GW detectors [1, 22, 38, 39].

A Zwick-Roell 200 kN machine [40], with a 25 kN load cell was used to strength test the samples in this study. A jig was specially made to hold and apply force to the bonded samples, shown in Figure 4. The metal foot of the jig was lowered down to the top of the bonded sample, contacting it via two metal rods a distance l apart. The sample rested on the two metal rods below it, a distance L apart. This ensured the even distribution of force to the bonded sample via four line contacts.

The loading arm of the machine provided the necessary force, F , to the bond interface. The starting point of the test was defined by pressing down on the bond sample with a user defined pre-load, in this case it was 1 N. The force at which each bond broke was then recorded and analysed.

The equation for the tensile strength of a bond, using the maximum recorded force registered at time of break is as follows [22]

$$\sigma_{\max} = \frac{3(L-l)F}{2bd^2}. \quad (7)$$

Where F is the force at break, L is the distance between the sample supports, l the distance between the

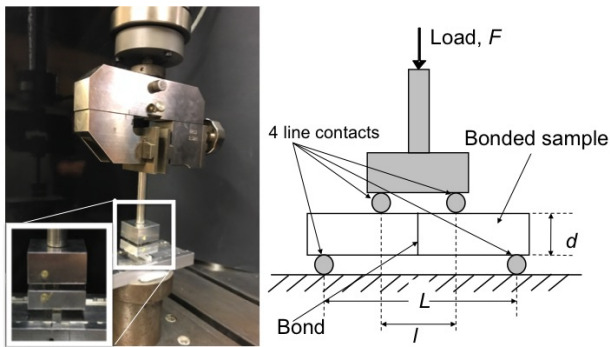

FIG. 4. On the left, a sapphire sample with hydroxide catalysis bond in the middle is shown in the strength tester. The schematic of four-point bend test is shown on the right.

rod contacts of the pressure foot, b is thickness and d is the width of the bonded sample as shown in the schematic in Figure 4. For this study, $L=34 \pm 0.1$ mm and $l=20 \pm 0.1$ mm for all samples. For the sapphire samples $b=d=5 \pm 0.05$ mm, and for the silicon and fused silica samples $b=10 \pm 0.1$ mm and $d=5 \pm 0.05$ mm.

VII. BREAKING STRESS RESULTS AND ANALYSIS

Previous research on hydroxide catalysis bonds between sapphire substrates and silicon substrates showed that the tensile strengths of the bonds were not adversely affected by cryogenic temperatures, or by thermal cycling from room temperature to cryogenic temperatures [22, 39, 41]. Research into the settling time of hydroxide catalysis bonds between fused silica substrates indicated that the siloxane chains begin to settle and become rigid seconds after the bond forms, while the water migration process may take weeks to months [21]. The bond strengths observed here were measured starting in the early stages of formation (one week), and then monitored throughout the curing process to longer periods of time (months). These bond strength values were measured for three kinds of substrate material (sapphire, silicon and fused silica), where all the samples had the same initial preparation and bond solution conditions. The combined results of these extensive measurements are presented for the first time in this paper.

The tensile strength results of the hydroxide catalysis bonds between sapphire, silicon, and fused silica substrates are reported here, for bonds of quality better than 80%. A fit of the form $A \cdot \exp(-B \cdot t) + C$ is used for all datasets, with the appropriate constants reported in the legend of each figure.

For bonds between sapphire substrates, curing times of 1 week to 30 weeks (7 months) were investigated. The results are shown in Figure 5. The average breaking stresses were 40 ± 1 MPa for one week old datasets, and 17.1 ± 0.8 MPa for those at 30 weeks of age. The fit

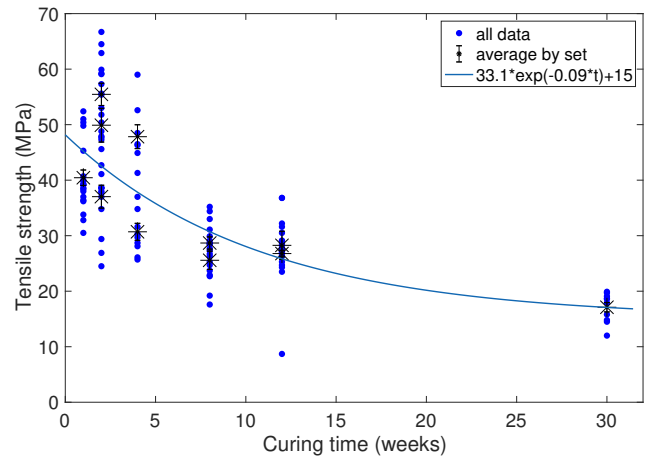

FIG. 5. Strength of hydroxide catalysis bonded c plane sapphire over time. Combined results by R. Douglas and M. Phelps, 2014-2017.

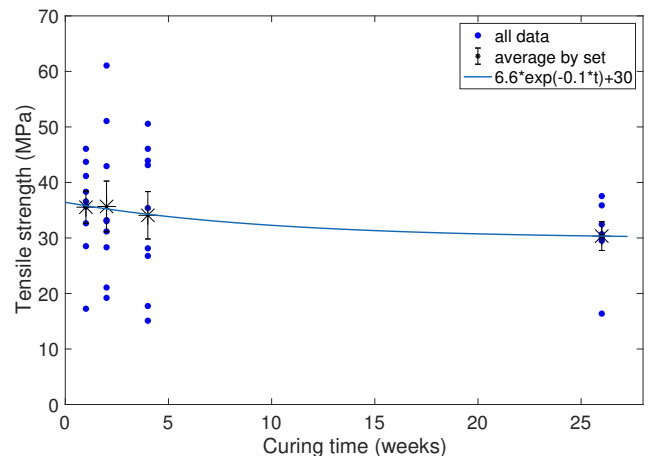

FIG. 6. Strength of hydroxide catalysis bonded fused silicon over time. Results by M. Masso Reid, 2018.

of the sapphire data suggests the strength stabilises at 15 ± 8 MPa, with a 95% confidence interval.

For bonds between silicon, curing times of one week to 26 weeks (6 months) were studied, the results of which are shown in Figure 6. Following the same motivation as that for the experiments with the sapphire samples, the curing time for the bonded silicon samples was chosen in order to investigate the formation and strength of the bond during the initial 4 week curing time. The 6 month curing time was chosen in order to investigate the strength and lifetime of any potential suspension where silicon is the chosen material. The average breaking stresses were 36 ± 3 MPa for one week old datasets, and 30 ± 3 MPa for those at 26 weeks of age. The fit of the silicon data suggests the strength stabilises at 30 ± 17 MPa, with a 95% confidence interval. The results presented here are in agreement with the maximum value recorded by Douglas

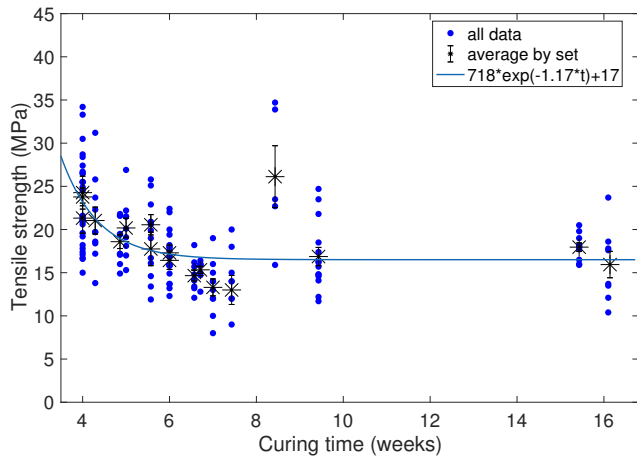

FIG. 7. Strength of hydroxide catalysis bonded fused silica over time. A.A. van Veggel, V. Mangano, K. Haughian, M. Kelly, and A. Jongschaap 2009-2014 combined results.

of 28 ± 2 MPa [42] as well as being in agreement with the control samples presented by Beveridge of 27 ± 1 MPa [22]. However, further testing of the strength of bonds at different ages is required in order to better establish the exponential trend.

The breaking strength datasets for bonds between fused silica substrates were collected over many years by different colleagues. They were compiled and analysed in this study for comparison to the sapphire and silicon results. Results for bonds of 4 weeks in age up to 16 weeks (3.7 months) are presented in Figure 7. The average breaking stresses for 4 week old bonds were 21 ± 1 MPa, 23 ± 1 MPa, and 24 ± 2 MPa. Bonds at 16 weeks of age were 16 ± 2 MPa. The fit of the fused silica data suggests the strength stabilises at 17 ± 1 MPa, with a 95% confidence interval.

In all three cases there is an initial decrease in bond strength. This stabilises over time as the bond cures, as can be seen in Figures 5-7. The initial drop in bond strength was concerning; if the hydroxide catalysis bond strength drops too low over time failure of the detector suspensions could become a concern. However, bonds between fused silica substrates also follow this trend, though they have joined together the fused silica test masses and suspension elements in ground-based detectors such as GEO 600 for more than 17 years without failing. In all cases the strength results stabilise above 15 MPa. The requirement for the tensile strength of hydroxide catalysis bonds in ground-based detectors such as KAGRA or Advanced LIGO is 1 MPa [7, 43], making a minimum value of 15 MPa more than acceptable for suspension design.

It is proposed that the initially higher bond strength seen in bonds between fused silica, sapphire, and silicon is due to the presence of water forming additional hydrogen bonds between itself, the developing bond lattice, and the substrate surfaces. The water, and thus the hy-

drogen bonds, leaves the interface gradually during the last dehydration stage through evaporation or diffusion into the bond substrates. It is at this point between the polymerisation stage and the end of the dehydration stage that we see the drop in tensile strength as the aluminosilicate lattice stabilises. This occurred at slightly different rates depending on which substrate material the bond was forming between, which can be correlated to the different diffusion rates of water in sapphire and silica substrates [44–46].

Additionally, in the literature the reflectivity and the refractive index of hydroxide catalysis bonds over time has been found to fluctuate the most during the first two weeks of curing, after which a steady change was noted until the bonds were a few months old [47]. There was very little change in the bonds’ optical properties from the age of a few months and older. For example, the refractive index of two sodium silicate bonds between fused silica substrates was found to change from 1.37 ± 0.01 to 1.44 ± 0.01 within the first three months, versus a change of 1.44 ± 0.01 to 1.45 ± 0.01 between the ages of three months to over a year [48]. This finding also suggests that when the hydroxide catalysis bonds between fused silica substrates are a few months old, they are fully cured and their material properties are unlikely to change drastically as they continue to age.

VIII. DISCUSSION AND CONCLUSIONS

We show that hydroxide catalysis bonds between fused silica substrates, sapphire substrates, and silicon substrates all exhibit a decrease in bond strength over the first few weeks of curing time. However, it can be seen that although the rate at which they decrease is different, the breaking stress stabilises above 15 MPa when the bond is fully cured.

Most importantly for GW detector design, we know that hydroxide catalysis bonded fused silica has been a part of GW detector suspensions for many years without failing. Thus the comparison of similar trends in strength over time of bonds made between fused silica to those made between sapphire and silicon indicates that hydroxide catalysis bonds continue to be a strong and reliable method of creating quasi-monolithic suspensions, especially for the crystalline materials that will be utilised in the next generation of cryogenic GW detectors.

IX. ACKNOWLEDGEMENTS

The authors would like to thank the UK Science and Technology Facilities Council (Grant numbers ST/I001085/1, ST/J000361/1, ST/L000946/1, ST/N005422/1), the University of Glasgow, the Scottish Funding Council and the Royal Society, A. A. van Veggel is the holder of a Royal Society Dorothy Hodgkin Fellowship, grant number DH12001, for financial support.

We would like to express our gratitude to our colleagues in the GEO600 and LIGO Scientific Collaboration for their interest in this area. The authors gratefully acknowledge the support of the United States National Science Foundation (NSF) for the construction and operation of the LIGO Laboratory and Advanced LIGO as well as the Science and Technology Facilities Council (STFC) of the United Kingdom, the Max-Planck Society (MPS), and the State of Niedersachsen/Germany for support of the construction of Advanced LIGO and construction and operation of the GEO600 detector. Additional support for Advanced LIGO was provided by the Australian Research Council.

- [1] A. A. van Veggel and C. J. Killow. Hydroxide catalysis bonding for astronomical instruments. *Advanced Optical Technologies*, 3(3), 2014.
- [2] E. J. Elliffe, J. Bogenstahl, A. Deshpande, J. Hough, C. Killow, S. Reid, D. Robertson, S. Rowan, H. Ward, and G. Cagnoli. Hydroxide-catalysis bonding for stable optical systems for space. *Classical and Quantum Gravity*, 22(10), 2005.
- [3] D. H. Gwo. Ultra precise and reliable bonding method: US 6,284,085 B1, 2001.
- [4] D. H. Gwo. Hydroxide catalyzed bonding: US 6,284,085 B1, 2003.
- [5] B. Willke, P. Aufmuth, C. Aulbert, S. Babak, R. Balasubramanian, B.W. Barr, S. Berukoff, S. Bose, G. Cagnoli, M.M. Casey, et al. The GEO 600 gravitational wave detector. *Classical and Quantum Gravity*, 19(7), 2002.
- [6] T. Accadia. Status of the Virgo project. *Classical and Quantum Gravity*, 28(114), 2011.
- [7] S. M. Aston, M. A. Barton, A. S. Bell, N. Beveridge, B. Bland, A. J. Brummitt, G. Cagnoli, et al. Update on quadruple suspension design for Advanced LIGO. *Classical and Quantum Gravity*, 29(23), 2012.
- [8] B. P. Abbott, R. Abbott, T. D. Abbott, M. R. Abernathy, et al. Observation of gravitational waves from a binary black hole merger. *Physical Review Letters*, 116, 2016.
- [9] B. P. Abbott, others (the LIGO Scientific Collaboration, and Virgo Collaboration). GW151226: Observation of gravitational waves from a 22 solar mass binary black hole coalescence. *Physical Review Letters*, 116, 2016.
- [10] B. P. Abbott, others (the LIGO Scientific Collaboration, and Virgo Collaboration). GW170104: Observation of 50 solar mass binary black hole coalescence at redshift 0.2. *Physical Review Letters*, 118, 2017.
- [11] B. P. Abbott, others (the LIGO Scientific Collaboration, and Virgo Collaboration). GW170608: Observation of a 19-solar-mass binary black hole coalescence. *Astrophysical Journal Letters*, 851, 2017.
- [12] B. P. Abbott, others (the LIGO Scientific Collaboration, and Virgo Collaboration). GW170814: A three-detector observation of gravitational waves from a binary black hole coalescence. *Physical Review Letters*, 119, 2017.
- [13] B. P. Abbott, others (the LIGO Scientific Collaboration, and Virgo Collaboration). GW170817: Observation of gravitational waves from a binary neutron star inspiral. *Physical Review Letters*, 119, 2017.
- [14] M. Punturo et al. The Einstein Telescope: a third-generation gravitational wave observatory. *Classical and Quantum Gravity*, 27(19), 2010.
- [15] B P Abbott et al. Exploring the sensitivity of next generation gravitational wave detectors. *Classical and Quantum Gravity*, 34(4), 2017.
- [16] V. B. Braginsky, V. P. Mitrofanov, and Panov. *Systems with Small Dissipation*. The University of Chicago Press, 1985.
- [17] D. H. Gwo. Ultra precise bonding for cryogenic fused silica optics. *SPIE*, 31(4), 1998.
- [18] Y. Aso and others (the KAGRA Collaboration). Interferometer design of the KAGRA gravitational wave detector. *Physical Review D*, (4), 2013.
- [19] A. V. Cumming, L. Cunningham, G. D. Hammond, K. Haughian, J. Hough, S. Kroker, I. W. Martin, R. Nawrodt, S. Rowan, C. Schwarz, and A. A. van Veggel. Silicon mirror suspensions for gravitational wave detectors. *Classical and Quantum Gravity*, 31(2), 2014.
- [20] R. Iler. *The Chemistry of Silica*. Wiley-Interscience Publication, 1979.
- [21] S. Reid, G. Cagnoli, E. Elliffe, J. Faller, J. Hough, et al. Influence of temperature and hydroxide concentration on the settling time of hydroxy-catalysis bonds. *Physics Letters A*, 22(10), 2007.
- [22] N. Beveridge, A. A. van Veggel, M. Hendry, P. Murray, R. A. Montgomery, E. Jesse, J. Scott, R. B. Bezensek, L. Cunningham, J. Hough, R. Nawrodt, S. Reid, and S. Rowan. Low-temperature strength tests and SEM imaging of hydroxide catalysis bonds in silicon. *Classical and Quantum Gravity*, 28, 2011.
- [23] B. E. Deal and A. S. Grove. General relationship for the thermal oxidation of silicon. *Journal of Applied Physics*, 1965.
- [24] E. J. Elliffe. *Aspects of Thermal Noise Modeling in Ground-Based Gravitational Wave Detectors and Developments of Hydroxide Catalysis Bonding for Space-Based Gravitational Wave Detectors and other Optical Applications*. PhD thesis, University of Glasgow, 2005.
- [25] M. Phelps. *Hydroxide Catalysis and Indium Bonding Research for the Design of Ground-Based Gravitational Wave Detectors*. PhD thesis, University of Glasgow, 2018.
- [26] J. Bowen et al. Adhesion between silica surfaces due to hydrogen bonding. *Surface Topography: Metrology and Properties*, 4(3), 2016.
- [27] S. Jenkins, K. Jacob, and S. Kumar. The effect of hydrogen bonding on the physical and mechanical properties of rigid-rod polymers. *Journal of Polymer Science Part B: Polymer Physics*, 38(23), 2000.
- [28] P. Przybysz, M. Dubowik, M. A. Kucner, K. Przybysz, B. Przybysz, and K. Buzala. Contribution of hydrogen bonds to paper strength properties. *Public Library of Science One*, 11(5), 2016.
- [29] L. Cunningham, P.G. Murray, A. Cunningham, E.J. Elliffe, G.D. Hammond, and K. Haughian. Re-evaluation of the mechanical loss factor of hydroxide-catalysis bonds and its significance for the next generation of gravitational wave detectors. *Physics Letters A*, 20, 2010.
- [30] Zygo. <https://www.zygo.com/?/metrology/interferometers/>. Last accessed on 25/01/2018.
- [31] Hitachi tabletop Scanning Electron Microscope. <https://www.hitachi-hightech.com>. Last accessed on 25/01/2018.
- [32] Wyko. <https://www.eriks.co.uk/>. Last accessed on 25/01/2018.
- [33] K. Green, J. Burke, and B. Oreb. Chemical bonding for precision optical assemblies. *Optical Engineering*, 50, 2011.
- [34] A. A. van Veggel. E050228-v4 silicate bonding procedure (hydroxide-catalysis bonding). Technical report, LSC, 2013.
- [35] Sigma aldrich. <https://www.sigmaaldrich.com>. Last accessed on 16/08/2018.

- [36] Eppendorf. <https://www.eppendorf.com>. Last accessed on 16/08/2018.
- [37] Standard test method for flexural strength of advanced ceramics at ambient temperature, ASTM C1161-13.
- [38] N. Beveridge. *Characterisation of Silicon-Silicon Hydroxide Catalysis Bonds for Future Gravitational Wave Detectors*. PhD thesis, University of Glasgow, 2012.
- [39] K. Haughian, R. Douglas, A. A. van Veggel, J. Hough, A. Khalaidovski, S. Rowan, T. Suzuki, and K. Yamamoto. The effect of crystal orientation on the cryogenic strength of hydroxide catalysis bonded sapphire. *Classical and Quantum Gravity*, 32(7), 2015.
- [40] Zwick strength tester. <http://www.zwick.co.uk/en/products/static-materials-testing-machines/testing-machines-from-5-kn-to-250-kn.html>. Last accessed on 25/01/2018.
- [41] R. Douglas, A. A. van Veggel, L. Cunningham, K. Haughian, J. Hough, and S. Rowan. Cryogenic and room temperature strength of sapphire jointed by hydroxide-catalysis bonding. *Classical and Quantum Gravity*, 31(4), 2014.
- [42] R. Douglas. *Aspects of hydroxide catalysis bonding of sapphire and silicon for use in future gravitational wave detectors*. PhD thesis, University of Glasgow, 2016.
- [43] D. Chen. *Study of a cryogenic suspension system for the gravitational wave telescope KAGRA*. PhD thesis, University of Tokyo, 2014.
- [44] R.H. Doremus. Diffusion of water in silica glass. *Journal of Materials Research, Volume 10, Issue 9,* 10(9), 1995.
- [45] R.H. Doremus. Diffusion in alumina. *Journal of Applied Physics* 100, 101301, 100(10), 2006.
- [46] H. Wakabayashi and M. Tomozawa. Diffusion of water into silica glass at low temperature. *Journal of the American Ceramic Society*, 72 1850-55, 72(18), 1989.
- [47] V. Mangano, A. A. van Veggel, R. Douglas, J. Faller, A. Grant, J. Hough, and S. Rowan. Determination of the refractive index and thickness of a hydroxide-catalysis bond between fused silica from reflectivity measurements. *Optical Express*, 25(4):3196–3213, 2017.
- [48] V. Mangano. *Studies of Some Properties of Hydroxide-Catalysis Bonds*. PhD thesis, University of Glasgow, 2018.