



# CHORUS

This is the accepted manuscript made available via CHORUS. The article has been published as:

## Optimal unambiguous discrimination of Bell-like states with linear optics

Dov Fields, János A. Bergou, Mark Hillery, Siddhartha Santra, and Vladimir S. Malinovsky

Phys. Rev. A **106**, 023706 — Published 8 August 2022

DOI: [10.1103/PhysRevA.106.023706](https://doi.org/10.1103/PhysRevA.106.023706)

# Optimal unambiguous discrimination of Bell-like states with linear optics

Dov Fields<sup>1</sup>, János A. Bergou<sup>2,3</sup>, Mark Hillery<sup>2,3</sup>, Siddhartha Santra<sup>1,4</sup>, Vladimir S. Malinovsky<sup>1</sup>

<sup>1</sup>*DEVCOM Army Research Laboratory, Adelphi, MD 20783*

<sup>2</sup>*Department of Physics and Astronomy, Hunter College of the City University of New York, New York, NY 10065*

<sup>3</sup>*Graduate Center of the City University of New York, New York, NY 10016*

<sup>4</sup>*Department of Physics, Indian Institute of Technology Bombay, Powai, Mumbai 400076, India*

Quantum information processing using linear optics is challenging due to the limited set of deterministic operations achievable without using complicated resource-intensive methods. While techniques such as the use of ancillary photons can enhance the information processing capabilities of linear optical systems they are technologically demanding. Therefore, determining the constraints posed by linear optics and optimizing linear optical operations for specific tasks under those constraints, without the use of ancillas, can facilitate their potential implementation. Here, we consider the task of unambiguously discriminating between Bell-like states using linear optics and without the use of ancillary photons. This is a basic problem relevant in diverse settings, for example, in the measurement of the output of an entangling quantum circuit or for entanglement swapping at a quantum repeater station. While it is known that exact Bell states of two qubits can be discriminated with an optimal success probability of 50% we find, surprisingly, that for Bell-like states the optimal probability can be only 25%. We analyze a set of Bell-like states in terms of their distinguishability, entanglement as measured by concurrence, and parameters of the beam-splitter network used for unambiguous discrimination. Further, we provide the linear optical configuration comprised of single photon detectors and beam splitters with input state-dependent parameters that achieves optimal discrimination in the Bell-like case.

## I. INTRODUCTION

Linear optical platforms are a promising route for building quantum information processing devices in computation [1], communication [2], and metrology [3]. On one hand, qubits encoded into the quantum state of a photon can have long coherence times [4, 5] and photonic circuits can potentially be scalably integrated [6–9]. On the other hand, there are fundamental limitations on the type of operations that can be implemented without prohibitive resource costs. A simple but important example of this kind of limitation is in the case of discriminating measurements on a set of mutually orthogonal entangled pure quantum states. In other platforms, such as superconducting qubits [10] or ion traps [11], there are no fundamental limitations on perfectly discriminating between the orthogonal states using measurements in arbitrary orthogonal bases. Whereas, in linear optical systems this is no longer the case: It may not be possible to achieve saturation of the quantum mechanically allowed statistical distinguishability among the given states using only linear optical setups. A case in point being the set of the four maximally entangled states of two qubits, or Bell states, only two of which can be discriminated without the use of ancillary photons.

In principle, given access to certain extra resources such as prepared entangled quantum states and ancillary photons, linear optical elements can be used to implement a universal set of operations for quantum information processing [12]. In particular, with increasing use of resources, Bell state discriminations can be implemented with a success probability asymptotically approaching 1 [13, 14]. However, increasing the number of ancillary

photons to achieve the stated precision is technologically challenging [1]. Without ancillary photons, only two of the four possible Bell states can be unambiguously discriminated, giving the protocol a maximum efficiency of 50% [15–17].

Generalizing this situation is the problem of unambiguously discriminating between a set of mutually orthogonal partially-entangled states of two qubits encoded into four photonic modes, which we call the set of Bell-like states. The formal structure of Bell-like states in terms of the mode creation operators is identical to that of the Bell states. However, the crucial difference is in the value of their concurrence which is strictly less than 1, i.e., they are partially entangled. Obtaining the linear optical operation that optimally discriminates between Bell-like states is, therefore, an important task since partially entangled states are realistic in the practical scenario. While conditions have been derived in order to determine whether a desired transformation is implementable using linear optics [18–20], these results have limited utility in determining the optimal transformation for specific tasks.

The goal of this paper is to derive the efficiency of optimal linear optical discrimination of Bell-like states and the corresponding setup, i.e., a network of beam-splitters and photon detectors which achieves the optimal efficiency. Our focus is on the case where no ancillary photons are used. The approach is to derive constraints required by unambiguous discrimination between the Bell-like states that allow us to construct feasible linear optical transformations under those constraints. The transformations are then optimized to maximize their probability of success. Completing these steps allows us to design a general method for optimally discriminating

any set of Bell-like states. We find that the efficiency, or maximum success probability, of the optimal unambiguous discrimination is only 25%, in contrast to the 50% that can be achieved for Bell states [15–17].

The structure of our paper is outlined as follows. In Sec. II, we review the basic mathematical framework underlying linear optical setups for state discrimination. Next, in Sec. III, we define the Bell-like states and proceed to derive the optimal unambiguous discrimination achievable using linear optical setups. We show, in particular, that only two out of the four given states can be successfully discriminated. In Sec. IV, we analyze the optical network allowing the optimal unambiguous discrimination between the Bell-like states showing the 25% efficiency of success. After presenting the results, we conclude by discussing some possible follow-up directions.

## II. LINEAR OPTICS FRAMEWORK FOR STATE DISCRIMINATION

Let us consider the discrimination of two-qubit quantum states, employing the dual-rail representation for qubits [1, 21, 22]. The basic elements of this representation are single mode photons described by the Fock states,  $|n_m\rangle \equiv \frac{\hat{a}_m^{\dagger n}}{\sqrt{n!}}|\emptyset\rangle$ , where  $\hat{a}_m^{\dagger}$  is the creation operator for the  $m$ -th photon mode,  $n_m$  is the number of photons in that mode, and  $|\emptyset\rangle$  is the vacuum mode. Qubit states in the dual-rail representation are given as:  $|0\rangle = |1_1, 0_2\rangle = \hat{a}_1^{\dagger}|\emptyset\rangle$ ,  $|1\rangle = |0_1, 1_2\rangle = \hat{a}_2^{\dagger}|\emptyset\rangle$ . Adding a second qubit can be represented by another photon in two other modes, giving the following two photon states:  $|00\rangle = \hat{a}_1^{\dagger}\hat{a}_3^{\dagger}|\emptyset\rangle$ ,  $|01\rangle = \hat{a}_1^{\dagger}\hat{a}_4^{\dagger}|\emptyset\rangle$ ,  $|10\rangle = \hat{a}_2^{\dagger}\hat{a}_3^{\dagger}|\emptyset\rangle$ ,  $|11\rangle = \hat{a}_2^{\dagger}\hat{a}_4^{\dagger}|\emptyset\rangle$ . Therefore, the first qubit is represented by one photon in the first two modes and the second qubit is represented by one photon in the second two modes. It is important to note that, by the nature of this representation, the computational space is only a subset of all possible states.

The relevance of this qubit encoding is that any transformation allowed by linear optical elements, i.e., any transformation using only beam splitter and phase shifter generators, can be described by unitary transformations on the creation and annihilation operators [23]. We can define the output operators  $\{\hat{b}_i^{\dagger}|i = 1 \dots m\}$  in terms of the input operators as  $\hat{b}_i^{\dagger} = \sum_j U_{ij}\hat{a}_j^{\dagger}$ . Note that the transformations allowed by linear optics only span an  $M$ -dimensional Hilbert space, where  $M$  is the total number of modes. The Fock space of  $n$  photons in  $M$  modes, however, spans a Hilbert space with  $\binom{M+n-1}{n}$  dimensions. Not all transformations in the full Fock space are achievable through linear optical setups, and it is this fundamental limitation that makes the perfect unambiguous discrimination of the Bell and Bell-like states

impossible.

Now we describe the generalized measurement scheme allowed by linear optical setups shown in Fig. 1. At the input of the scheme are the photon modes  $\{\hat{a}_i^{\dagger}|i = 1 \dots 4\}$  that can be coupled with auxiliary photon modes  $\{\hat{a}_i^{\dagger}|i = 5 \dots m\}$ . These input modes are connected to the output modes  $\{\hat{b}_i^{\dagger}|i = 1 \dots m\}$  utilizing beam splitters and phase shifters. Some of the output modes can be detected by photon resolving detectors, while the photons in the remaining modes can be treated as a new states that can be used as an input for further processing.

For the purposes of this paper, we restrict our consideration to a special class of linear optical schemes, where the auxiliary photon modes are empty. Additionally, we focus only on the optimal measurement for a single iteration, barring the use of conditional measurements.

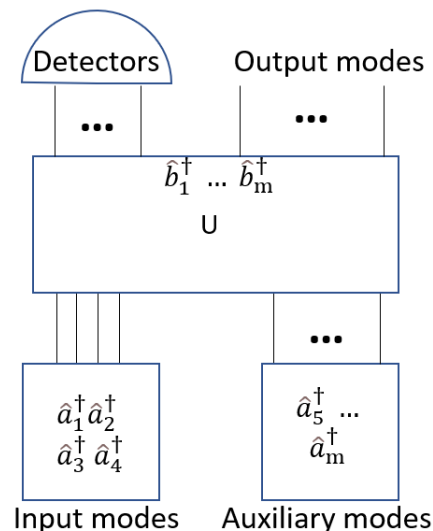

FIG. 1. The general scheme for linear optical operations. The input modes,  $\hat{a}_i^{\dagger}$  (the system,  $i = 1, 2, 3, 4$ ) and the auxiliary modes (the ancilla,  $i = 5, \dots, m$ ) are coupled via a network of beam splitters and phase shifters to form the output modes. The action of the linear optic network can be described by a total unitary transformation  $U$ . At the output, some of the modes are measured using photon resolving detectors, while the remaining undetected modes can be used as input for further processing.

## III. BELL-LIKE STATES DISCRIMINATION

In order to derive the optimal unambiguous discrimination of Bell-like states using linear optical setups, we will divide our analysis into 3 distinct sections. First,

we will define the Bell-like states and give a general formula for calculating the probability of any two photon detections occurring as a function of both the input state and the unitary that describes the linear optical network. Specifically, define the unitary in terms of its orthonormal column vectors, allowing us to calculate a detection output probabilities as a function of the input state and two columns of this unitary. Following this, we will look specifically at the case of discriminating the  $|\Psi_3\rangle$  state. We will be able to define specific constraints on what orthonormal vectors can be used in order to produce a detection result that can be used for unambiguous discrimination. Finally, by using the derived constraints, we will give the form a unitary that will result in the unambiguous discrimination of  $|\Psi_3\rangle$  in one of the output detections. By analyzing the remaining detection outcomes, we will determine the parameters that will give the optimal discrimination of 25% of the Bell-like states.

### A. Defining Bell-like states and calculating detection probabilities

Bell-like states can be defined as

$$|\Psi_1\rangle = \left( \alpha_1 \hat{a}_1^\dagger \hat{a}_3^\dagger + \beta_1 \hat{a}_2^\dagger \hat{a}_4^\dagger \right) |\emptyset\rangle, \quad (1)$$

$$|\Psi_2\rangle = \left( \beta_1^* \hat{a}_1^\dagger \hat{a}_3^\dagger - \alpha_1^* \hat{a}_2^\dagger \hat{a}_4^\dagger \right) |\emptyset\rangle, \quad (2)$$

$$|\Psi_3\rangle = \left( \alpha_2 \hat{a}_1^\dagger \hat{a}_4^\dagger + \beta_2 \hat{a}_2^\dagger \hat{a}_3^\dagger \right) |\emptyset\rangle, \quad (3)$$

$$|\Psi_4\rangle = \left( \beta_2^* \hat{a}_1^\dagger \hat{a}_4^\dagger - \alpha_2^* \hat{a}_2^\dagger \hat{a}_3^\dagger \right) |\emptyset\rangle, \quad (4)$$

where  $\alpha_i$  and  $\beta_i$  are the complex coefficients normalized by  $|\alpha_i|^2 + |\beta_i|^2 = 1$ . The Bell states are recovered for  $\alpha_1 = \beta_1 = \alpha_2 = \beta_2 = 1/\sqrt{2}$ .

As we mentioned above, the most general operation implementable by linear optics has the form  $\hat{b}_i^\dagger = \sum_j^M U_{ij} \hat{a}_j^\dagger$ , and the inverse transformation yields  $\hat{a}_i^\dagger = \sum_j^M U_{ji}^* \hat{b}_j^\dagger$ . We should note that despite only having four input modes with photons, we allow for the possibility that our discrimination protocol can be improved by allowing for  $t$  additional output modes, resulting in a total of  $M = 4 + t$  modes. Therefore we can define an arbitrary two-qubit state as  $|e\rangle = \sum_{(j,k) \in \sigma} \alpha_{jk} \hat{a}_j^\dagger \hat{a}_k^\dagger |\emptyset\rangle$ , where  $\sigma \equiv \{(j,k) | j = 1, 2; k = 3, 4\}$ . It should be noted that the form of  $|e\rangle$  assumes that there are no ancillary photon modes. Using these expressions we can write the

input modes in the basis of the output modes:

$$\begin{aligned} |e\rangle &= \sum_{(j,k) \in \sigma} \alpha_{jk} \hat{a}_j^\dagger \hat{a}_k^\dagger |\emptyset\rangle, \\ &= \sum_{(j,k) \in \sigma} \alpha_{jk} \left( \sum_l^M U_{lj}^* \hat{b}_l^\dagger \right) \left( \sum_m^M U_{mk}^* \hat{b}_m^\dagger \right) |\emptyset\rangle, \\ &= \sum_m^M \sum_{(j,k) \in \sigma} \alpha_{jk} U_{mj}^* U_{mk}^* \hat{b}_m^\dagger \hat{b}_m^\dagger |\emptyset\rangle \\ &\quad + \sum_{l < m}^{M,M} \sum_{(j,k) \in \sigma} \alpha_{jk} (U_{lj}^* U_{mk}^* + U_{mj}^* U_{lk}^*) \hat{b}_l^\dagger \hat{b}_m^\dagger |\emptyset\rangle. \end{aligned} \quad (5)$$

Since the measurements are performed in the orthonormal basis of photon modes, we just need to evaluate the probabilities of detecting a various combination of two photons for a given state. The probability of detecting two photon in mode  $m$  is

$$\begin{aligned} |\langle 2_m | e \rangle|^2 &= 2 \left| \sum_{(j,k) \in \sigma} \alpha_{jk} U_{mj}^* U_{mk}^* \right|^2 = 2 | (U^* N U^\dagger)_{mm} |^2 \\ &= 2 |\langle \phi_m | N | \phi_m^* \rangle|^2 \\ &= \frac{1}{2} |\langle \phi_m | (N + N^\top) | \phi_m^* \rangle|^2, \end{aligned} \quad (6)$$

while the detection probability of one photon in mode  $m$  and another in mode  $n$  is

$$\begin{aligned} |\langle 1_m, 1_n | e \rangle|^2 &= \left| \sum_{(j,k) \in \sigma} \alpha_{jk} (U_{nj}^* U_{mk}^* + U_{mj}^* U_{nk}^*) \right|^2 \\ &= | (U^* N U^\dagger)_{nm} + (U^* N U^\dagger)_{mn} |^2 \\ &= |\langle \phi_n | (N + N^\top) | \phi_m^* \rangle|^2, \end{aligned} \quad (7)$$

where  $N$  is an  $M \times M$  matrix whose only nonzero elements are  $N_{jk} \equiv \alpha_{jk}$  for  $(j,k) \in \sigma$ .  $|\phi_m^*\rangle$  is the  $m^{\text{th}}$  column of  $U^\dagger$ , and  $|\phi_m\rangle$  is the  $m^{\text{th}}$  column of  $U^\top$ . From the previous two equations, the probability of detecting two photons in any mode for an input state  $|e\rangle$  is  $c |\langle \phi_n | (N + N^\top) | \phi_m^* \rangle|^2$ , where  $c = 1 - \frac{\delta_{mn}}{2}$ .

For easier analysis of this equation, it is helpful to note that there is a linear transformation,  $\pi$ , that maps the vectors  $|\Psi_\mu\rangle$  to matrices  $\pi(|\Psi_\mu\rangle)$  such that  $\pi(|\Psi_\mu\rangle) = N_\mu + N_\mu^\top$ . In order to understand this transformation, let us define the following matrix  $A_e$  that is a straightforward transformation of  $|e\rangle$ :

$$A_e = \begin{pmatrix} \alpha_{13} & \alpha_{14} \\ \alpha_{23} & \alpha_{24} \end{pmatrix}. \quad (8)$$

This simple matrix is an element of the 4 dimensional vector space of  $2 \times 2$  complex matrices with the inner product  $\text{tr}(A^\dagger B)$ . We can then explicitly give  $\pi(|e\rangle)$  using this matrix:

$$\pi(|e\rangle) = \begin{pmatrix} 0_{2 \times 2} & A_e & 0_{2 \times t} \\ A_e^\top & 0_{2 \times 2} & 0_{2 \times t} \\ 0_{t \times 2} & 0_{t \times 2} & 0_{t \times t} \end{pmatrix}. \quad (9)$$

Here, we have defined  $0_{t \times t}$  as a matrix of size  $t \times t$  with the elements of 0. It is helpful to note that the 0 elements of this matrix correspond to the fact that there are no ancillary input photons. This representation of  $\pi(|e\rangle)$  makes it obvious that  $\pi(|e\rangle)^\top = \pi(|e\rangle)$ . In order to see how this operator acts on the  $4 + t$  dimensional vector  $|\phi_m^*\rangle$ , it is helpful to decompose  $|\phi_m^*\rangle$  as a direct sum of two two-dimensional vectors,  $|u_m^*\rangle \in \mathcal{H}_2$  and  $|v_m^*\rangle \in \mathcal{H}_2$  and one  $t$  dimensional vector,  $|w_m^*\rangle \in \mathcal{H}_t$ :  $|\phi_m^*\rangle \equiv |u_m^*\rangle \oplus |v_m^*\rangle \oplus |w_m^*\rangle$ , where:

$$|u_m^*\rangle = \begin{pmatrix} U_{m1}^* \\ U_{m2}^* \end{pmatrix}, |v_m^*\rangle = \begin{pmatrix} U_{m3}^* \\ U_{m4}^* \end{pmatrix}, |w_m^*\rangle = \begin{pmatrix} U_{m5}^* \\ \vdots \\ U_{mt}^* \end{pmatrix}. \quad (10)$$

Given this, we can see that  $\pi(|e\rangle)|\phi_m^*\rangle = A_e |v_m^*\rangle \oplus A_e^\top |u_m^*\rangle \oplus 0$ .

Using the linearity of the representation  $\pi$  and the definition of the Bell-like states given in Eqs. (1) - (4), we can determine the two photon detection probabilities for these states:

$$c |\langle \phi_l | \pi(\Psi_1) | \phi_m^* \rangle|^2 = c |\alpha_1 \langle \phi_l | \pi(|00\rangle) | \phi_m^* \rangle + \beta_1 \langle \phi_l | \pi(|11\rangle) | \phi_m^* \rangle|^2, \quad (11)$$

$$c |\langle \phi_l | \pi(\Psi_2) | \phi_m^* \rangle|^2 = c |\beta_1^* \langle \phi_l | \pi(|00\rangle) | \phi_m^* \rangle - \alpha_1^* \langle \phi_l | \pi(|11\rangle) | \phi_m^* \rangle|^2, \quad (12)$$

$$c |\langle \phi_l | \pi(\Psi_3) | \phi_m^* \rangle|^2 = c |\alpha_2 \langle \phi_l | \pi(|01\rangle) | \phi_m^* \rangle + \beta_2 \langle \phi_l | \pi(|10\rangle) | \phi_m^* \rangle|^2, \quad (13)$$

$$c |\langle \phi_l | \pi(\Psi_4) | \phi_m^* \rangle|^2 = c |\beta_2^* \langle \phi_l | \pi(|01\rangle) | \phi_m^* \rangle - \alpha_2^* \langle \phi_l | \pi(|10\rangle) | \phi_m^* \rangle|^2. \quad (14)$$

## B. Restrictions on transformations resulting in the unambiguous discrimination of $|\Psi_3\rangle$ in a detection output

In the previous subsection, we derived a simple method for calculating the probability of detecting one photon in mode  $l$  and one photon in mode  $m$ ,  $P(1_l, 1_m)$ , for all four Bell-like states. In order for such a detection to contribute to the unambiguous discrimination of one of the four input states, this probability needs to be zero for three of the input states and non-zero for the remaining state. If, e.g., we want this detection event to contribute to the unambiguous discrimination of  $|\Psi_3\rangle$ , we get the conditions:

$$\alpha_1 \langle \phi_l | \pi(|00\rangle) | \phi_m^* \rangle = -\beta_1 \langle \phi_l | \pi(|11\rangle) | \phi_m^* \rangle, \quad (15)$$

$$\alpha_1^* \langle \phi_l | \pi(|11\rangle) | \phi_m^* \rangle = \beta_1^* \langle \phi_l | \pi(|00\rangle) | \phi_m^* \rangle, \quad (16)$$

$$\langle \phi_l | \pi(\Psi_3) | \phi_m^* \rangle \neq 0, \quad (17)$$

$$\beta_2^* \langle \phi_l | \pi(|01\rangle) | \phi_m^* \rangle = \alpha_2^* \langle \phi_l | \pi(|10\rangle) | \phi_m^* \rangle. \quad (18)$$

For completeness, Eq. (17) can be explicitly written as:

$$\alpha_2 \langle \phi_l | \pi(|01\rangle) | \phi_m^* \rangle \neq \beta_2 \langle \phi_l | \pi(|10\rangle) | \phi_m^* \rangle. \quad (19)$$

We first look at the consequences of the conditions, Eqs. (15), (16), and (19), and will deal with the consequences of the final conditions (18) in the next subsection. Multiplying Eqs. (15) and (16), and rearranging the result slightly, yields

$$(|\alpha_1|^2 + |\beta_1|^2) \langle \phi_l | \pi(|00\rangle) | \phi_m^* \rangle \langle \phi_l | \pi(|11\rangle) | \phi_m^* \rangle = 0. \quad (20)$$

Due to the normalization condition  $|\alpha_1|^2 + |\beta_1|^2 = 1$ , the only way to satisfy this and both of Eqs. (15) and (16) is for  $\langle \phi_l | \pi(|00\rangle) | \phi_m^* \rangle = \langle \phi_l | \pi(|11\rangle) | \phi_m^* \rangle = 0$ . We should note that these two conditions hold for all values of  $\alpha$  and  $\beta$ , i.e., they hold unconditionally.

One convenient way of satisfying these conditions is by choosing  $|\phi_{l,m}\rangle$  such that either  $\pi(|11\rangle)|\phi_m^*\rangle = 0$  or  $\pi(|11\rangle)|\phi_l^*\rangle = 0$ . It is worth noting that if we choose both of these options, the condition from Eq. (17) (or (19)) cannot be satisfied. If we start by choosing  $\pi(|11\rangle)|\phi_m^*\rangle = 0$  we get the following:

$$\begin{pmatrix} 0 & 0 \\ 0 & 1 \end{pmatrix} |v_m^*\rangle \oplus \begin{pmatrix} 0 & 0 \\ 0 & 1 \end{pmatrix} |u_m^*\rangle = 0. \quad (21)$$

In order to satisfy this equation, we require:

$$|v_m^*\rangle \propto \begin{pmatrix} 1 \\ 0 \end{pmatrix}, \quad |u_m^*\rangle \propto \begin{pmatrix} 1 \\ 0 \end{pmatrix}, \quad (22)$$

resulting in the following form for  $|\phi_m^*\rangle$ :

$$|\phi_m^*\rangle = \varphi_{m1} \begin{pmatrix} 1 \\ 0 \end{pmatrix} \oplus \varphi_{m2} \begin{pmatrix} 1 \\ 0 \end{pmatrix} \oplus \varphi_{m3} |w_m^*\rangle \quad (23)$$

Here,  $|w_m^*\rangle$  is an arbitrary normalized  $t$  dimensional vector. The normalization of  $|\phi_m^*\rangle$  is enforced by the condition  $\sum_i^3 |\varphi_{mi}|^2 = 1$ . Additionally, it is worth noting that there exists one alternate solution where both  $|v_m^*\rangle = |u_m^*\rangle = 0$ . However, with such a solution Eq. (17) cannot be satisfied. Applying the same approach to  $\langle \phi_l | \pi(|00\rangle) | \phi_m^* \rangle = 0$ , we see that choosing  $\pi(|00\rangle)|\phi_m^*\rangle = 0$  requires  $|\phi_m^*\rangle = 0$ . This choice violates the condition in Eq. (17) and, hence, cannot contribute to unambiguous discrimination. This leaves us with setting  $\pi(|00\rangle)|\phi_l^*\rangle = 0$ , giving:

$$|\phi_l^*\rangle = \varphi_{l1} \begin{pmatrix} 0 \\ 1 \end{pmatrix} \oplus \varphi_{l2} \begin{pmatrix} 0 \\ 1 \end{pmatrix} \oplus \varphi_{l3} |w_l^*\rangle \quad (24)$$

The orthogonality condition  $\langle \phi_l^* | \phi_m^* \rangle = \delta_{lm}$  is preserved by requiring that  $\langle w_l^* | w_m^* \rangle = \delta_{lm}$ . With some simple substitution, we can see that the probability of successfully discriminating  $|\Psi_3\rangle$ , given this detection, is  $|\langle \phi_l | \pi(|\Psi_3\rangle) | \phi_m^* \rangle|^2 = |\alpha_2 \varphi_{l1} \varphi_{m2} + \beta_2 \varphi_{m1} \varphi_{l2}|^2$ . Using the triangle inequality, we get  $|\langle \phi_l | \pi(|\Psi_3\rangle) | \phi_m^* \rangle| \leq |\alpha_2 \varphi_{l1} \varphi_{m2}| + |\beta_2 \varphi_{m1} \varphi_{l2}|$ . Using the normalizations  $\sum_i^3 |\varphi_{mi}|^2 = 1$  and  $\sum_i^3 |\varphi_{li}|^2 = 1$ , it is clear that this term is maximal when  $\varphi_{l3} = \varphi_{m3} = 0$ . From this point, we can confidently state that the optimal solution is to reduce our total number of output modes to 4. Despite allowing for additional output modes, we can

conclude that without allowing for ancillary input photons, additional output modes will not assist in the unambiguous discrimination of the Bell-like states. At this point, by considering the requirements of unambiguous discrimination from a single detection, we have derived significant restrictions on the form the unitary must take if the network it represents will have an output detection that will contribute to the unambiguous discrimination of  $|\Psi_3\rangle$ . If we, without loss of generality, choose that a measurement of  $|1_1, 1_2\rangle$  ( $m=1, l=2$ ) should unambiguously discriminate  $|\Psi_3\rangle$ , we can use this to determine the first two columns of the unitary as follows:

$$U^\dagger = \begin{pmatrix} \cos \omega_1 & 0 & \cdots & \cdots \\ 0 & \cos \omega_2 & \cdots & \cdots \\ \sin \omega_1 e^{i\rho_1} & 0 & \cdots & \cdots \\ 0 & \sin \omega_2 e^{i\rho_2} & \cdots & \cdots \end{pmatrix}. \quad (25)$$

In this equation, we have satisfied the condition  $|\varphi_{i1}|^2 + |\varphi_{i2}|^2 = 1$  by defining  $\varphi_{i1} = \cos \omega_i$  and  $\varphi_{i2} = e^{i\rho_i} \sin \omega_i$  for  $i=1, 2$ . The 3rd and 4th columns of this unitary will be determined in the next section.

Finally, we are left to consider the consequences of the final condition, Eq. (18). Using the condition from Eq. (18), we get that if we want a measurement of  $|1_1, 1_2\rangle$  to unambiguously discriminate  $|\Psi_3\rangle$  then we need

$$\beta_2^* \cos \omega_1 \sin \omega_2 e^{i\rho_2} = \alpha_2^* \cos \omega_2 \sin \omega_1 e^{i\rho_1}. \quad (26)$$

This gives us one of two equations that we will use to determine the final unitary.

### C. Unambiguous discrimination from other detection results

Having considered the consequences of requiring the measurement of  $|1_1, 1_2\rangle$  to contribute to the unambiguous discrimination of  $|\Psi_3\rangle$ , we can now focus on the usefulness of the remaining outputs, for instance,  $|1_1, 1_4\rangle$ . Assuming that we want our detector to be able to succeed for more than one of the input states, we need to look at using this output to discriminate a different state. If we choose the output  $|1_1, 1_4\rangle$  to unambiguously discriminate  $|\Psi_4\rangle$ , we can use the analysis above to require that Eq. (24) also apply to  $|\phi_4^*\rangle$ . If we do this, it is straightforward to show that Eqs. (15) and (16) are already satisfied. This fixes the full form of our unitary:

$$U^\dagger = \begin{pmatrix} \cos \omega_1 & 0 & -\sin \omega_1 e^{-i\rho_1} & 0 \\ 0 & \cos \omega_2 & 0 & -\sin \omega_2 e^{-i\rho_2} \\ \sin \omega_1 e^{i\rho_1} & 0 & \cos \omega_1 & 0 \\ 0 & \sin \omega_2 e^{i\rho_2} & 0 & \cos \omega_2 \end{pmatrix}$$

The only other condition, which can be derived in the same fashion as Eq. (26), that needs to be satisfied is:

$$\alpha_2 \cos \omega_1 \cos \omega_2 = \beta_2 \sin \omega_1 \sin \omega_2 e^{i(\rho_1 - \rho_2)}. \quad (27)$$

Solving equations (26) and (27) simultaneously gives  $\cos \omega_1 = \sin \omega_1 = \frac{1}{\sqrt{2}}$  and  $\frac{\alpha_2}{\beta_2} = \tan \omega_2 e^{i(\rho_1 - \rho_2)}$ .  $\rho_1$  is not fixed by these equations and we can, without loss of generality, choose  $\rho_1 = 0$ . Combining everything we derive the following unitary:

$$U^\dagger = \begin{pmatrix} \frac{1}{\sqrt{2}} & 0 & -\frac{1}{\sqrt{2}} & 0 \\ 0 & \beta_2^* & 0 & -\alpha_2 \\ \frac{1}{\sqrt{2}} & 0 & \frac{1}{\sqrt{2}} & 0 \\ 0 & \alpha_2^* & 0 & \beta_2 \end{pmatrix}. \quad (28)$$

This unitary is fixed, other than a total phase factor of  $e^{i\rho_1}$ , and all that is left is to determine whether any of the remaining detections of photons contribute to the unambiguous discrimination of any state. Using the unitary above, we can see that the detections of  $|1_2, 1_3\rangle$  or  $|1_3, 1_4\rangle$  could only contribute to the unambiguous discrimination of  $|\Psi_3\rangle$  or  $|\Psi_4\rangle$  when either  $|\alpha_2|^2 = |\beta_2|^2$  or  $\alpha_2 \beta_2 = 0$ . Thus, it is clear that these two detections can only be useful in unambiguously discriminating ideal Bell states or separable states. Similarly, we can see that any of the remaining detections will only ever be useful for the unambiguous discrimination of either  $|\Psi_1\rangle$  or  $|\Psi_2\rangle$  when the input states are separable. For Bell-like states, only detections of photons in the  $|1_1, 1_2\rangle$  and  $|1_1, 1_4\rangle$  will result in successful unambiguous discrimination. The probabilities of measuring photons in these detectors when their associated states are sent can be calculated as  $|\langle \phi_1 | \pi(|\Psi_3\rangle) | \phi_2^* \rangle|^2 = |\langle \phi_1 | \pi(|\Psi_4\rangle) | \phi_4^* \rangle|^2 = \frac{1}{2}$ . If we assume that each state will be sent with equal probability, this unitary will successfully discriminate  $|\Psi_3\rangle$  and  $|\Psi_4\rangle$  with an optimal probability of 25%.

What we have ultimately shown in this section is that there is no linear optical setup that will enable better than a 25% probability of successfully discriminating any set of Bell-like states. In order to reach this conclusion, we first gave a general calculation of the probability of two photon measurement occurring for each of the Bell-like states in Eqs. (11) - (14). Following this, we focused specifically on  $|\Psi_3\rangle$  and derived, in Eqs. (23) and (26), specific restrictions on the unitary defining the linear optical transformation in order for it to allow for the unambiguous discrimination of  $|\Psi_3\rangle$  in one of the two photon measurements. Finally, after choosing for the  $|1_1, 1_2\rangle$  mode contribute to unambiguous discrimination, we analyzed what remaining detection outcomes could be used for successful unambiguous discrimination. Our specific choices of the  $|1_1, 1_2\rangle$  and  $|1_1, 1_4\rangle$  measurements was arbitrary, and a similar analysis would follow if we started by choosing any other modes. A permutation of the above unitary would be derived, which would cause different two photon detectors to be useful for the unambiguous discrimination task. Similarly, instead of having started from trying to unambiguously discriminate  $|\Psi_3\rangle$ , we could have started from any other state. For instance, following similar arguments as above, we could have found the following unitary, which unambiguously

discriminates  $|\Psi_1\rangle$  and  $|\Psi_2\rangle$  with a probability of 25%:

$$U^\dagger = \begin{pmatrix} \beta_1^* & 0 & 0 & -\alpha_1 \\ 0 & \frac{1}{\sqrt{2}} & -\frac{1}{\sqrt{2}} & 0 \\ 0 & \frac{1}{\sqrt{2}} & \frac{1}{\sqrt{2}} & 0 \\ \alpha_1^* & 0 & 0 & \beta_1 \end{pmatrix}. \quad (29)$$

Ultimately, we conclude that the optimal probability of unambiguous discrimination of Bell-like states in linear optical systems is 25%, when no ancillary photons are introduced.

#### IV. IMPLEMENTATION AND ANALYSIS

In the previous section, we provide a rigorous proof of the optimal method of discriminating between Bell-like states. In this section, we explicitly provide and analyze the optical setup. Specifically, our goal is to better understand the relationship between the entanglement of the input states and the success probability of unambiguous discrimination. First, without loss of generality, we can, for convenience, choose all of four parameters in Eqs. (1)-(4) to be real and rewrite the possible Bell-like states in the form:

$$|\Psi_1\rangle = \left( \sin \theta_1 \hat{a}_1^\dagger \hat{a}_3^\dagger + \cos \theta_1 \hat{a}_2^\dagger \hat{a}_4^\dagger \right) |\emptyset\rangle, \quad (30)$$

$$|\Psi_2\rangle = \left( \cos \theta_1 \hat{a}_1^\dagger \hat{a}_3^\dagger - \sin \theta_1 \hat{a}_2^\dagger \hat{a}_4^\dagger \right) |\emptyset\rangle, \quad (31)$$

$$|\Psi_3\rangle = \left( \sin \theta_2 \hat{a}_1^\dagger \hat{a}_4^\dagger + \cos \theta_2 \hat{a}_2^\dagger \hat{a}_3^\dagger \right) |\emptyset\rangle, \quad (32)$$

$$|\Psi_4\rangle = \left( \cos \theta_2 \hat{a}_1^\dagger \hat{a}_4^\dagger - \sin \theta_2 \hat{a}_2^\dagger \hat{a}_3^\dagger \right) |\emptyset\rangle. \quad (33)$$

We can also use concurrence as an entanglement measurement for these states, calculating concurrence for these states as follows:  $C_{1,2} = |\sin(2\theta_1)|$ ,  $C_{3,4} = |\sin(2\theta_2)|$ . The unitary in Eq. (28) can be implemented by two beam splitters. Before looking explicitly at the optimal solution, it is first helpful to consider any general two beam splitter strategy:

$$\begin{pmatrix} \hat{b}_1^\dagger \\ \hat{b}_3^\dagger \end{pmatrix} = \begin{pmatrix} \cos \phi_1 & \sin \phi_1 \\ -\sin \phi_1 & \cos \phi_1 \end{pmatrix} \begin{pmatrix} \hat{a}_1^\dagger \\ \hat{a}_3^\dagger \end{pmatrix}, \quad (34)$$

$$\begin{pmatrix} \hat{b}_2^\dagger \\ \hat{b}_4^\dagger \end{pmatrix} = \begin{pmatrix} \cos \phi_2 & \sin \phi_2 \\ -\sin \phi_2 & \cos \phi_2 \end{pmatrix} \begin{pmatrix} \hat{a}_2^\dagger \\ \hat{a}_4^\dagger \end{pmatrix}. \quad (35)$$

This setup is depicted in Fig. 2 (a), while the setup in Fig. 2 (b) requires mapping  $3 \leftrightarrow 4$  in the previous equations. In order to simplify our analysis, we will fix the first beam splitter to be a 50/50 beam splitter,  $\phi_1 = \frac{\pi}{4}$ .

Using this, we calculate the probabilities of measuring each possible outcome for each possible input state. In Table I,  $P(m,n)$  is the probability of detecting one photon in detector  $m$  and one photon in detector  $n$ . If we swap the two beam splitters, then we get the same table, but with  $1 \leftrightarrow 2$  and  $3 \leftrightarrow 4$ . If we swap the interactions,

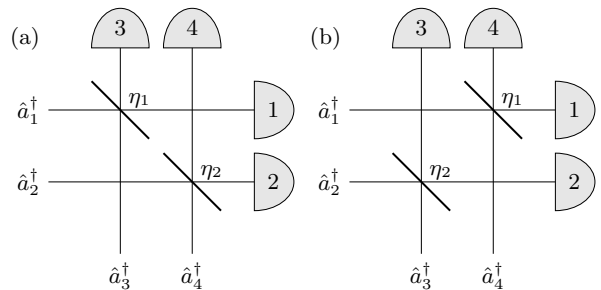

FIG. 2. Discrimination of Bell-like states, with two beam splitters defined by  $\eta_1$  and  $\eta_2$ . As described in Eqs. (34) and (35), in (a) modes 1 and 3 interact in the first beam splitter and modes 2 and 4 interact in the second. In (b), modes 1 and 4 interact in the first beam splitter and modes 2 and 3 interact in the second.

as depicted in Fig. 2 (b), such that the first beam splitter has the 1 and 4 modes as its input and the second beam splitter has 2 and 3 as its input, we also get a similar table, but with the first two and the last two rows of this table swapped and with  $\theta_1 \leftrightarrow \theta_2$ . For each output, we can use Bayes' Theorem to calculate the confidence [24, 25]:

$$P(|\Psi_i\rangle | m, n) = \frac{P(m, n | |\Psi_i\rangle) p(|\Psi_i\rangle)}{\sum_i P(m, n | |\Psi_i\rangle) p(|\Psi_i\rangle)}, \quad (36)$$

$$D(m, n) = \max_i \{P(|\Psi_i\rangle | m, n)\}. \quad (37)$$

Here, we have defined  $P(m, n | |\Psi_i\rangle)$  as the probability of a given detection outcome of one photon in the  $m$  detector and one photon in the  $n$  detector for the input state  $|\Psi_i\rangle$ . The confidence  $P(|\Psi_i\rangle | m, n)$  is the probability that the input state was  $|\Psi_i\rangle$  given that a detection of one photon in each of the  $m$  and  $n$  detectors occurred.  $D(m, n)$  is the maximum confidence for this measurement. In addition, we have assumed that all Bell-like states are sent with equal probability:  $p(|\Psi_i\rangle) = \frac{1}{4}$ . One final note is that Eq. (36) only holds when the denominator is non-zero.

This calculation of confidence gives us a clear way to relate the entanglement of the input states to the ability to use specific detection measurements for unambiguous discrimination. The maximum confidence  $D(m, n)$  is a measure of how well a detection of one photon in mode  $m$  and one photon in mode  $n$  can be correlated to one of the input states. When the maximum confidence is  $\frac{1}{4}$  there is no correlation between the detection and any input state and when the maximum confidence is 1 there is perfect correlation between the detection and the associated input state. In the case where maximum confidence is 1, that detection results in the unambiguous discrimination of one of the input states. From all the columns of the table we only get 3 different equations for maximum

TABLE I. Probability of each possible combination of photon detections for each input state (setup described in Figure 2 (a)). When  $\phi_2 = \theta_2$  then a detection of  $|1_1, 1_2\rangle$  unambiguously discriminates  $|\Psi_3\rangle$  and a detection of  $|1_1, 1_4\rangle$  unambiguously discriminates  $|\Psi_4\rangle$ .

In/Out	$P(1, 1)$	$P(2, 2)$	$P(3, 3)$	$P(4, 4)$	$P(1, 2)$	$P(1, 3)$	$P(1, 4)$	$P(2, 3)$	$P(2, 4)$	$P(3, 4)$
$ \Psi_1\rangle$	$\frac{\sin^2 \theta_1}{2}$	$\frac{\cos^2 \theta_1 \sin^2(2\phi_2)}{2}$	$\frac{\sin^2 \theta_1}{2}$	$\frac{\cos^2 \theta_1 \sin^2(2\phi_2)}{2}$	0	0	0	0	$\cos^2 \theta_1 \cos^2(2\phi_2)$	0
$ \Psi_2\rangle$	$\frac{\cos^2 \theta_1}{2}$	$\frac{\sin^2 \theta_1 \sin^2(2\phi_2)}{2}$	$\frac{\cos^2 \theta_1}{2}$	$\frac{\sin^2 \theta_1 \sin^2(2\phi_2)}{2}$	0	0	0	0	$\sin^2 \theta_1 \cos^2(2\phi_2)$	0
$ \Psi_3\rangle$	0	0	0	0	$\frac{\cos^2(\theta_2 - \phi_2)}{2}$	0	$\frac{\sin^2(\theta_2 - \phi_2)}{2}$	$\frac{\cos^2(\theta_2 + \phi_2)}{2}$	0	$\frac{\sin^2(\theta_2 + \phi_2)}{2}$
$ \Psi_4\rangle$	0	0	0	0	$\frac{\sin^2(\theta_2 - \phi_2)}{2}$	0	$\frac{\cos^2(\theta_2 - \phi_2)}{2}$	$\frac{\sin^2(\theta_2 + \phi_2)}{2}$	0	$\frac{\cos^2(\theta_2 + \phi_2)}{2}$

confidence:

$$D(1, 1) = D(2, 2) = D(3, 3) = D(4, 4) = D(1, 3) \equiv D_1$$

$$D(1, 2) = D(1, 4) \equiv D_2.$$

$$D(2, 3) = D(3, 4) \equiv D_3.$$

$$D_1 = \frac{1 + \sqrt{1 - C_1^2}}{2}. \quad (38)$$

$$D_2 = \frac{1 + |\sqrt{1 - C_3^2} \cos(2\phi_2) + C_3 \sin(2\phi_2)|}{2}. \quad (39)$$

$$D_3 = \frac{1 + |\sqrt{1 - C_3^2} \cos(2\phi_2) - C_3 \sin(2\phi_2)|}{2}. \quad (40)$$

$D_1$  is the maximum confidence for any detection of two photons in the same mode, while  $D_2$  and  $D_3$  are the confidences gained by the detection of photons in either  $\{|1_1, 1_2\rangle, |1_1, 1_4\rangle\}$  or  $\{|1_2, 1_3\rangle, |1_3, 1_4\rangle\}$ , respectively. In Fig. 3, we illustrate a plot of both  $D_2$  and  $D_3$  as functions of  $C_3$  and  $\phi_2$ . Since unambiguous discrimination is only achieved when the maximum confidence is 1, we can see that since  $D_1 = 1$  is only satisfied for  $C_1 = 0$ , detections of two photons in the same mode only contributes to unambiguous discrimination when the first two states are separable. In order to satisfy either  $D_2 = 1$  or  $D_3 = 1$ , or equivalently for the associated detections to contribute to unambiguous discrimination, we only need to choose  $\phi_2 = \theta_2$  or  $\phi_2 = \frac{\pi}{2} - \theta_2$  respectively, which is the optimal solution derived in the previous section and results in the unitary given in Eq. (28) up to a simple permutation of the unitary. For both  $D_2 = 1$  and  $D_3 = 1$  to be satisfied, we either need  $C_3 = 1$  and  $\phi_2 = \frac{\pi}{4}$ , which is the case for Bell states, or  $C_3 = 0$  and  $\phi_2 = 0$ , which is the case for separable states.

This analysis makes it clear that the unambiguous linear optical discrimination of Bell-like states is not a monotonic function of entanglement, or equivalently, concurrence. Rather, for all Bell-like states, only one of  $D_2 = 1$  or  $D_3 = 1$  can be satisfied, and therefore the Bell-like states can only be successfully discriminated with a probability of 25%. We can see this from Table II. If we choose  $\frac{\pi}{4} > \theta_1, \theta_2 > 0$ , we can see that  $|\Psi_3\rangle$  is unambiguously discriminated when one photon is measured in each of modes 1 and 2.  $|\Psi_4\rangle$  is unambiguously discriminated when the one photon is measured in each of modes 1 and 4.  $|\Psi_1\rangle$  and  $|\Psi_2\rangle$  are never successfully discriminated, while  $|\Psi_3\rangle$  and  $|\Psi_4\rangle$  are successfully discriminated half of the time they are received, giving a total success rate of

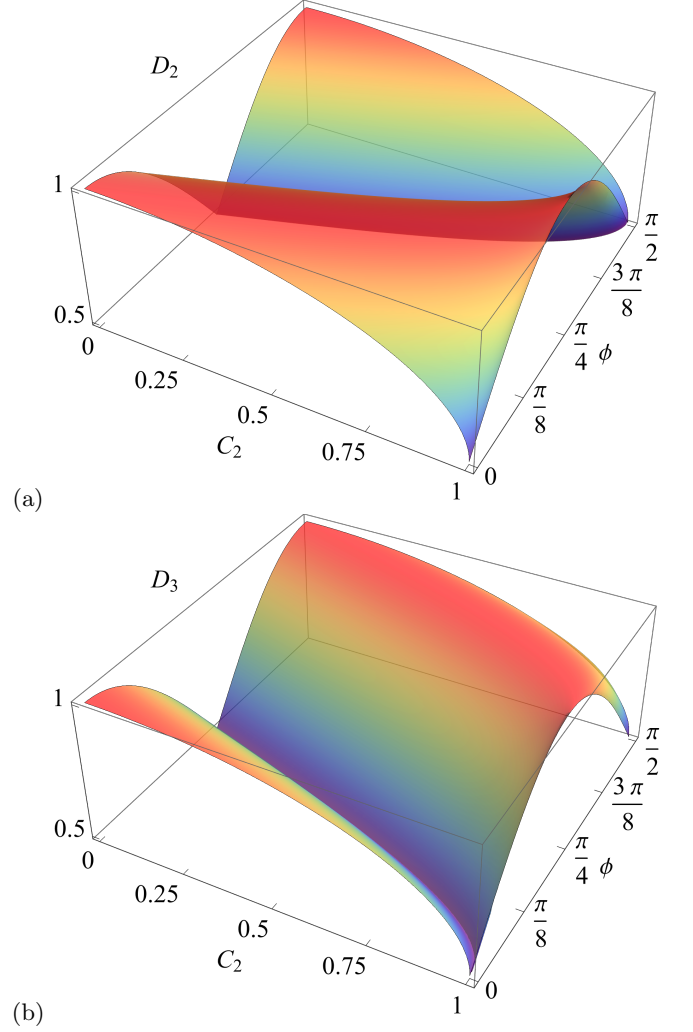

FIG. 3. A plot of the confidences (a)  $D_2$  and (b)  $D_3$  as a function of the concurrence  $C_3$  and the beam splitter parameter  $\phi$ .

25%. For Bell states, both  $D_2 = 1$  and  $D_3 = 1$  can be satisfied, allowing for a success probability of 50% for the discrimination and reproducing the results in [15–17]. In Table II, we can see this result by choosing  $\theta_1 = \theta_2 = \frac{\pi}{4}$ . Similar to the Bell-like case,  $|\Psi_1\rangle$  and  $|\Psi_2\rangle$  are never successfully discriminated. However,  $|\Psi_3\rangle$  is successfully discriminated upon a detection of one photon in each



TABLE II. Probability of each possible combination of photon detections for each input state when the beam splitter in Eqs. (34) and (35) are set such that  $\phi_1 = \frac{\pi}{4}$  and  $\phi_2 = \theta_2$

In/Out	$P(1, 1)$	$P(2, 2)$	$P(3, 3)$	$P(4, 4)$	$P(1, 2)$	$P(1, 3)$	$P(1, 4)$	$P(2, 3)$	$P(2, 4)$	$P(3, 4)$
$ \Psi_1\rangle$	$\frac{\sin^2 \theta_1}{2}$	$\frac{\cos^2 \theta_1 \sin^2(2\theta_2)}{2}$	$\frac{\sin^2 \theta_1}{2}$	$\frac{\cos^2 \theta_1 \sin^2(2\theta_2)}{2}$	0	0	0	0	$\cos^2 \theta_1 \cos^2(2\theta_2)$	0
$ \Psi_2\rangle$	$\frac{\cos^2 \theta_1}{2}$	$\frac{\sin^2 \theta_1 \sin^2(2\theta_2)}{2}$	$\frac{\cos^2 \theta_1}{2}$	$\frac{\sin^2 \theta_1 \sin^2(2\theta_2)}{2}$	0	0	0	0	$\sin^2 \theta_1 \cos^2(2\theta_2)$	0
$ \Psi_3\rangle$	0	0	0	0	$\frac{1}{2}$	0	0	$\frac{\cos^2(2\theta_2)}{2}$	0	$\frac{\sin^2(2\theta_2)}{2}$
$ \Psi_4\rangle$	0	0	0	0	0	0	$\frac{1}{2}$	$\frac{\sin^2(2\theta_2)}{2}$	0	$\frac{\cos^2(2\theta_2)}{2}$

of modes 1 and 2 or one photon is detected in each of modes 3 and 4.  $|\Psi_4\rangle$  is successfully discriminated when one photon is detected in each of modes 1 and 4 or one photon is detected in each of modes 2 and 3. In total, for Bell states when either  $|\Psi_1\rangle$  or  $|\Psi_2\rangle$  are received the discrimination fails, while when  $|\Psi_3\rangle$  and  $|\Psi_4\rangle$  are received, the discrimination succeeds, giving a success rate of 50% for the total protocol. For completely separable states,  $D_1 = D_2 = D_3 = 1$  can be satisfied, allowing for complete discrimination between the four states. We can see this from Table II by setting  $\theta_1 = \theta_2 = 0$ . In this case we see that a detection of one photon in each of the modes 2 and 4 will unambiguously discriminate  $|\Psi_1\rangle$ , while a detection of two photons in mode 1 or a detection of two photons in mode 3 will unambiguously discriminate  $|\Psi_2\rangle$ .  $|\Psi_3\rangle$  and  $|\Psi_4\rangle$  can be unambiguously discriminated, as in the previous example.

## V. CONCLUSION

In this paper we have derived the optimal efficiency of unambiguous discrimination between Bell-like states possible with linear optical setups without the need for ancillary photons. We have explicitly shown that the optimal efficiency for Bell-like states is only 25%, as opposed to the 50% success rate possible for Bell states. The reduced symmetry of the Bell-like states results in fewer outputs that can be useful for unambiguous discrimination. When analyzed in terms of the entanglement measure of the set of states, the optimal efficiency

shows a discontinuity between the set of Bell-like states and exact Bell-states. The main conclusion is that the upper bound for the success probability of unambiguous discrimination between Bell-like states is 25%. This result is independent of the concurrence  $C$  of the states for  $0 < C < 1$ , while  $C = 0$ , separable states, and  $C = 1$ , maximally entangled states, emerge as singular points. Previous works on Bell states simply prove that the proposed transformation is optimal, in this paper we obtained specific constraints on the unitary and used these constraints to derive and construct the optimal discrimination protocol. The systematic approach presented in this paper has the potential to assist in optimizing other types of linear optical discrimination problems. In follow up work, we intend to consider more general classes of orthogonal entangled states. In addition, there is still room to explore optical setups for unambiguous discrimination that make use of ancillary photons. One final possible extension of this work is using this approach to derive the optimal minimum error discrimination, or even more general strategies, allowed by linear optical setups.

## VI. ACKNOWLEDGEMENTS

This research was sponsored by the DEVCOM Army Research Laboratory and was accomplished under Cooperative Agreement Number W911NF-20-2-0097. The authors would like to thank Michael Goerz for helpful discussions.

- 
- [1] P. Kok, W. J. Munro, Kae Nemoto, T. C. Ralph, J. P. Dowling, and G. J. Milburn, *Rev. Mod. Phys.* **79**, 135 (2007).
- [2] K. Azuma, K. Tamaki, and H. K. Lo, *Nat. Commun* **6**, 6787 (2015).
- [3] J. P. Olson, K. R. Motes, P. M. Birchall, N. M. Studer, Margarite LaBorde, T. Moulder, P. P. Rohde, and J. P. Dowling, *Phys. Rev. A* **96**, 013810 (2017).
- [4] J. F. Chen, Z. Han, P. Qian, L. Zhou, and W. Zhang, in *Proc. 11th Conference on Lasers and Electro-Optics Pacific Rim (CLEO-PR)*, 2015, pp. 1-2.
- [5] Z. Han, P. Qian, L. Zhou, *et al.*, *Sci Rep* **5**, 9126 (2015).
- [6] X. Gan, R. J. Shiue, Y. Gao, I. Meric, T. F. Heinz, K. Shepard, J. Hone, S. Assefa, *et al.*, *Nat. Photonics* **7**, 883 (2013).
- [7] A. W. Elshaari, W. Pernice, K. Srinivasan, *et al.*, *Nat. Photonics* **14**, 285 (2020).
- [8] J. Wang, F. Sciarrino, A. Laing, *et al.*, *Nat. Photonics* **14**, 273 (2020).
- [9] W. Bogaerts, D. Pérez, J. Capmany, *et al.*, *Nature* **586**, 207 (2020).
- [10] M. Kjaergaard, Mollie E. Schwartz, J. Braumüller, P. Krantz, Joel I.-J. Wang, S. Gustavsson, and W. D. Oliver, *Annual Review of Condensed Matter Physics* **11**, 369 (2020).
- [11] C. D. Bruzewicz, J. Chiaverini, R. McConnell, and J. M. Sage, *Applied Physics Reviews* **6**, 021314 (2019).

- [12] E. Knill, R. Laflamme, and G. J. Milburn, *Nature* **409**, 46 (2001).
- [13] W. P. Grice, *Phys. Rev. A* **84**, 042331 (2011).
- [14] F. Ewert and P. van Loock, *Phys. Rev. Lett.* **113**, 140403 (2014).
- [15] N. Lütkenhaus, J. Calsamiglia, and K.-A. Suominen, *Phys. Rev. A* **59**, 3295 (1999).
- [16] L. Vaidman and N. Yoran, *Phys. Rev. A* **59**, 116 (1999).
- [17] J. Calsamiglia and N. Lütkenhaus, *Applied Physics B* **71**, 67 (2001).
- [18] P. van Loock and N. Lütkenhaus, *Phys. Rev. A* **69**, 012302 (2004).
- [19] P. van Loock, K. Nemoto, W. J. Munro, P. Raynal, and N. Lütkenhaus, *Phys. Rev. A* **73**, 062320 (2006).
- [20] J. C. Garcia-Escartin, V. Gimeno, and J. J. Moyano-Fernández, *Phys. Rev. A* **100**, 022301 (2019),
- [21] T. C. Ralph and G. J. Pryde, *Progress in Optics* **54**, 209 (2010).
- [22] L. A. Wu, P. Walther, D. Lidar, *Sci. Rep.* **3**, 1394 (2013).
- [23] M. Reck, A. Zeilinger, H. J. Bernstein, and P. Bertani, *Phys. Rev. Lett.* **73**, 58 (1994)
- [24] S. Croke, E. Andersson, S. M. Barnett, C. R. Gibson, and J. Jeffers, *Phys. Rev. Lett.* **96**, 070401 (2006).
- [25] U. Herzog, *Phys. Rev. A* **79**, 032323 (2009).